

REPLACEMENT PARTS MANUAL

EXTRA HIGH EFFICIENCY II CONDENSING GAS FURNACE CH - SERIES

Manual 2110-856

Revision F

Date 9-23-91

Supersedes 8-30-91

* GENERAL NOTES *

*Revised and/or additional pages may be issued from time to time.
*A complete and current manual consists of pages dated as shown in the following index.

** INDEX **

<u>Page</u>	<u>Description</u>	<u>Page</u>	<u>Date</u>	<u>Supersedes</u>
	Cabinet Components--Exploded View	1	g-23-91	3-22-91
"	" --Usage List	2	g-23-91	3-22-91
	Functional Components--Exploded View	3	g-23-91	Z-19-90
"	" --Usage List	4	g-23-91	8-30-91

*** IMPORTANT ***

Contact the installing and/or local Bard distributor for all parts requirements. Make sure you have the complete model and serial number available from the unit rating plate.

UPFLOW CABINET COMPONENT PARTS

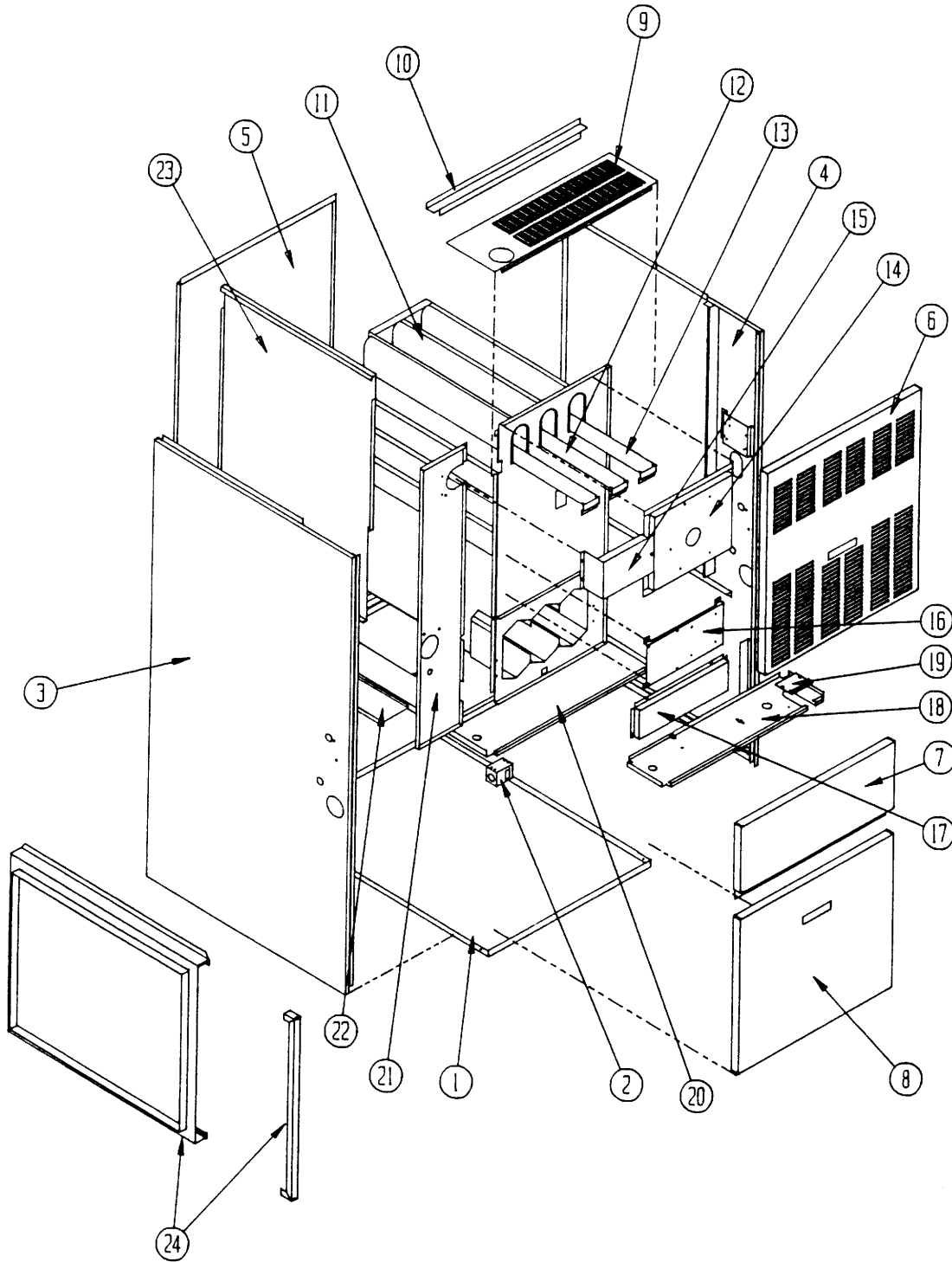

Date: 9-23-91
Supersedes: 3-22-91

UPPELOW CABINET COMPONENT PARTS LIST

Dwg. No.	Part No.	Description	C H O 6 0 D 3 6 B	C H O 8 0 D 4 8 B	C H O 1 0 0 6 0 D
1	127-189	Lower Base Spotweld Assembly	x		
1	127-190	Lower Base Spotweld Assembly		x	
1	127-191	Lower Base Spotweld Assembly			x
2	112-031	Door Switch Bracket	x	x	x
3	501-182	Left Side Assembly	x	x	x
4	501-181	Right Side Assembly	x	x	x
5	508-018	Back Assembly	x		
5	508-019	Back Assembly		x	
5	508-073	Back Assembly			x
6	152-148	Vestibule Door	x		
6	152-149	Vestibule Door		x	
6	152-150	Vestibule Door			x
7	152-145	Burner Door	x		
7	152-146	Burner Door		x	
7	152-147	Burner Door			x
8	152-151	Blower Door	x		
8	152-152	Blower Door		x	
8	152-153	Blower Door			x
9	106-111	Top Fill	x		
9	106-112	Top Fill		x	
9	106-113	Top Fill			x
10	140-134	Plenum Support	x		
10	140-135	Plenum Support		x	
10	140-136	Plenum Support			x
11	171-158	Heat Exchanger Assembly	x		
11	171-159	Heat Exchanger Assembly		x	
11	171-160	Heat Exchanger Assembly			x
12	168-013	Flue Baffle--Short		x	x
13	168-002	Flue Baffle	x	x	x
14	913-0039	Flue Collector Box Assembly	x		
14	913-0036	Flue Collector Box Assembly		x	
14	913-0042	Flue Collector Box Assembly			x
15	169-034	IDB Transition	x		
15	169-035	IDB Transition Assembly		x	
15	169-036	IDB Transition Assembly			x
*16	112-088	Ignition Module Bracket	x		
*16	112-100	Control Mounting Bracket		x	x
17	168-003	Secondary Air Baffle	x		
17	168-008	Secondary Air Baffle		x	
17	168-010	Secondard Air Baffle			x

Dwg. No.	Part No.	Description	C H O 6 0 D 3 6 B	C H O 8 0 D 4 8 B	C H O 1 0 0 6 0 D
18	120-149	Burner Compartment Partition			x
18	120-147	Burner Compartment Partition	x		
18	120-148	Burner Compartment Partition		x	
19	136-131	Manifold Fill Plate	x	x	
19	136-132	Manifold Fill Plate			x
20	127-149	Blower Base Weld Assembly	x		
20	127-120	Blower Base Weld Assembly		x	
20	127-146	Blower Base Weld Assembly			x
21	520-119	Coil Partition	x	x	x
22	140-133	Support Coil	x	x	x
23	134-098	Coil Shield	x	x	
23	134-099	Coil Shield			x
24	919-0002	Filter Rack W/Door	x	x	
24	919-0003	Filter Rack W/Door			x

*80,000 and 100,000 ignition module bracket shown.

Date: 9-23-91
Supersedes: 3-22-91

UPELOW FUNCTIONAL COMPONENT PARTS

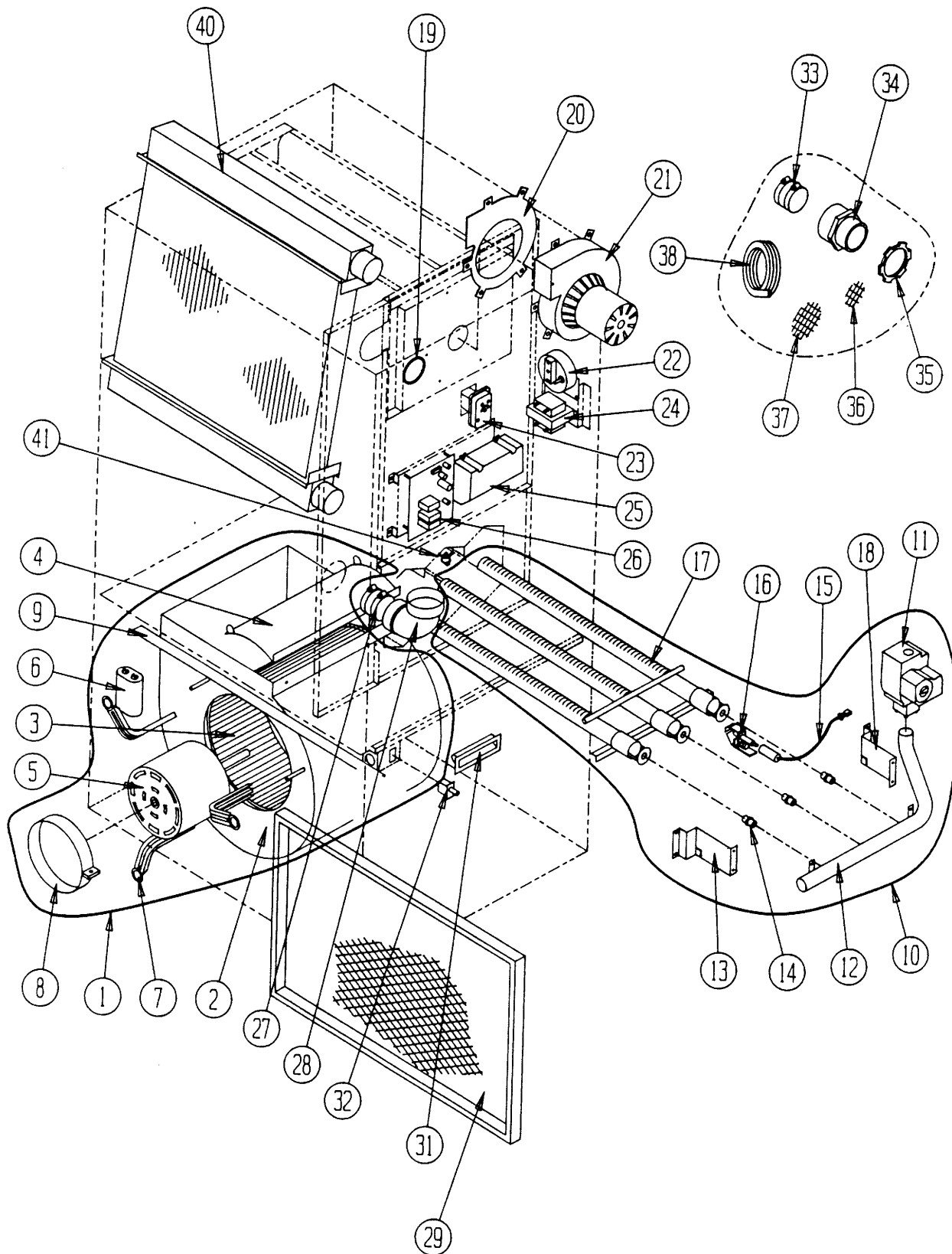

Date: 9-23-91
Supersedes: 2-19-90

2110-856

UPFLOW FUNCTIONAL COMPONENT PARTS LIST

Dwg. No.	Part No.	Description	C H O 6 0 D 3 6 B	C H O 8 0 D 4 8 B	C H O 0 0 D 6 0 B
1	900-100	Blower Assembly	x		
1	900-101	Blower Assembly		x	
1	900-102	Blower Assembly			x
2	151-085	Blower Housing	x		
2	151-074	Blower Housing		x	
2	151-084	Blower Housing			x
3	5152-013	Blower Wheel	x		
3	5152-059	Blower Wheel		x	
3	5152-061	Blower Wheel			x
4	144-127	Diffuser	x		
4	144-129	Diffuser		x	
4	144-131	Diffuser			x
5	8105-008	Motor	x		
5	8106-018	Motor		x	
5	8107-004	Motor			x
6	8552-002	Capacitor	x		
6	8552-004	Capacitor		x	
6	8552-026	Capacitor			x
7	8200-034	Motor Mount Leg	x	x	
7	8200-035	Motor Mount Leg			x
8	8200-033	Motor Mount Strap	x	x	x
9	104-796	Blower Angle	x		
9	104-792	Blower Angle		x	x
10	901-0083	Burner Assembly	x		
10	901-0082	Burner Assembly		x	
10	901-0084	Burner Assembly			x
11	5651-062	Gas Valve	x	x	x
12	5818-019	Gas Manifold	x		
12	5818-020	Gas Manifold		x	
12	5818-021	Gas Manifold			x
13	112X095	Left Manifold Bracket	x	x	x
14	9010-010	Gas Orifice Spud	x		
14	9010-046	Gas Orifice Spud		x	x
15	8600-009	Ignition Cable	x	x	x
16	8620-038	Pilot Assembly	x	x	x
17	9010-036	Burner Venturi	x		
17	9010-037	Burner Venturi		x	
17	9010-038	Burner Venturi			x
18	112X095	Right Manifold Bracket	x	x	x
19	1921-020	Silicone Die-Cut Gasket	x	x	x
20	1921-019	IDB Gasket	x	x	x
21	8620-033	Induced Draft Blwr Assy Kit	x	x	x

Dwg. No.	Parts No.	Description	C H O 6 0 D 3 6 B	C H O 8 0 D 4 8 B	C H O 0 0 D 6 0 B
22	8406-043	Pressure Switch	x		
22	8406-041	Pressure Switch			x
22	8406-042	Pressure Switch		x	
23	8620-032	Limit Assembly	x	x	x
24	8407-039	Transformer	x	x	x
25	5651-073	Ignition Module	x	x	x
26	8201-053	Blower Control	x	x	x
27	6093-007	"No Hub" Connector	x	x	x
28	6095-005	90 Degree Street Elbow	x	x	x
29	7003-004	16x25x1 Permanent	x	x	x
31	1171-025	Door Pull	x	x	x
32	8406-013	Door Switch	x	x	x
33	6093-008	"No Hub" Connector	x	x	x
34	6093-006	2" Male Adapter	x	x	x
35	8611-063	2" Conduit Lock Nut	x	x	x
36	7002-009	2" Bird Screen	x	x	x
37	7002-008	3" Bird Screen	x	x	x
38	5452-005-6000	Vinyl Drain Hose	x	x	x
*39	8620-031	Condensate Neutralizer	x	x	x
40	5055-001	Coil Assembly	x	x	x
41	8406-037	Flame Rollout Switch	x	x	x
	4046-108	Wiring Diagram	x	x	x
	8620-040	Pilot Gas Tube W/Fittings	x	x	x

*Not pictured.

Date: 9-23-91
Supersedes: 8-30-91

2110-856

Page: 4