

REPLACEMENT PARTS MANUAL

EXTRA HIGH EFFICIENCY II CONDENSING GAS FURNACE CH--SERIES

Manual 2110-856

Revision I

Date 5-04-92

Supersedes 5-07-92

* GENERAL NOTES *

*Revised and/or additional pages may be issued from time to time.
*A complete and current manual consists of pages dated as shown in the following index.

** INDEX **

<u>Page Description</u>	<u>Page</u>	<u>Date</u>	<u>Supersedes</u>
Cabinet Components--Exploded View	1	2-07-92	9-23-91
" " --Usage List	2	2-07-92	10-28-91
Functional Components--Exploded View	3	2-07-92	9-23-91
" " --Usage List	4	5-04-92	9-23-91

*** IMPORTANT ***

Contact the installing and/or local Bard distributor for all parts requirements. Make sure you have the complete model and serial number available from the unit rating plate.

BARD MANUFACTURING COMPANY

BRYAN, OHIO 43506

UPFLOW CABINET COMPONENT PARTS

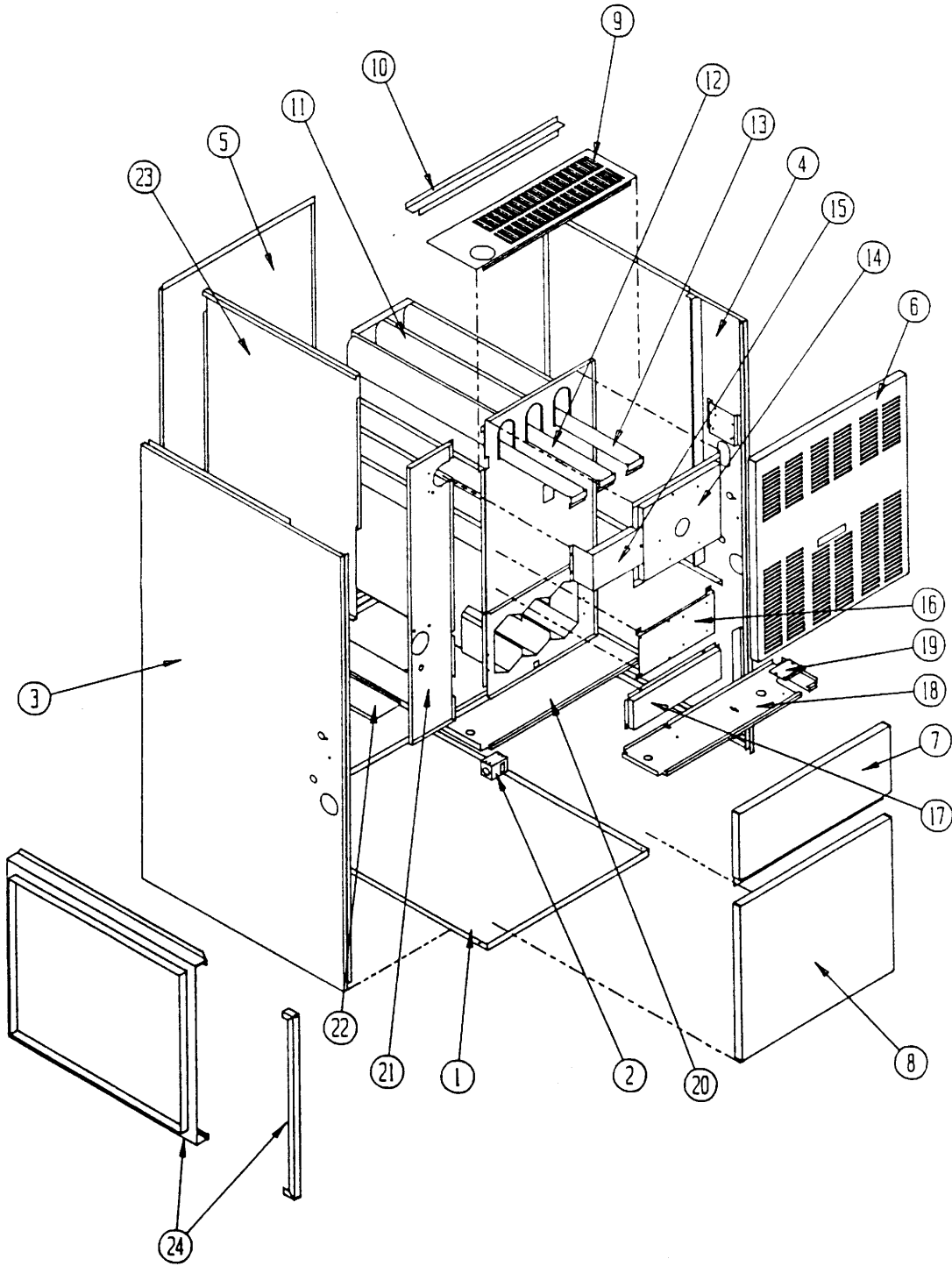

Date: 2-07-92
Supersedes: 9-23-91

UPFLOW CABINET COMPONENT PARTS LIST

Dwg. No.	Part No.	Description	C H O 6 0 D 3 6 B	C H O 8 0 D 4 8 B	C H O 1 0 0 0 6 0 B
1	127-189	Lower Base Spotweld Assembly	x		
1	127-190	Lower Base Spotweld Assembly		x	
1	127-191	Lower Base Spotweld Assembly			x
2	112-031	Door Switch Bracket	x	x	x
3	501-241	Left Side Assembly	x	x	x
4	501-240	Right Side Assembly	x	x	x
5	508-018	Back Assembly	x		
5	508-019	Back Assembly		x	
5	508-073	Back Assembly			x
6	152-148	Vestibule Door	x		
6	152-149	Vestibule Door		x	
6	152-150	Vestibule Door			x
7	152-145	Burner Door	x		
7	152-146	Burner Door		x	
7	152-147	Burner Door			x
8	152-039	Blower Door	x		
8	152-043	Blower Door		x	
8	152-153	Blower Door			x
9	106-111	Top Fill	x		
9	106-112	Top Fill		x	
9	106-113	Top Fill			x
10	140-134	Plenum Support	x		
10	140-135	Plenum Support		x	
10	140-136	Plenum Support			x
11	171-158	Heat Exchanger Assembly	x		
11	171-159	Heat Exchanger Assembly		x	
11	171-160	Heat Exchanger Assembly			x
12	168-013	Flue Baffle--Short		x	x
13	168-002	Flue Baffle	x	x	x
14	913-0039	Flue Collector Box Assembly	x		
14	913-0036	Flue Collector Box Assembly		x	
14	913-0042	Flue Collector Box Assembly			x
15	169-034	IDB Transition	x		
15	169-035	IDB Transition Assembly		x	
15	169-036	IDB Transition Assembly			x
*16	112-088	Ignition Module Bracket	x		
*16	112-100	Control Mounting Bracket		x	x
17	168-003	Secondary Air Baffle	x		
17	168-008	Secondary Air Baffle		x	
17	168-010	Secondary Air Baffle			x

*80,000 and 100,000 ignition module bracket shown.

Dwg. No.	Part No.	Description	C H O 6 0 D 3 6 B	C H O 8 0 D 4 8 B	C H O 1 0 0 0 6 0 B
18	120-149	Burner Compartment Partition			x
18	120-147	Burner Compartment Partition	x		
18	120-148	Burner Compartment Partition		x	
19	136-131	Manifold Fill Plate	x	x	
19	136-132	Manifold Fill Plate			x
20	127-149	Blower Base Weld Assembly	x		
20	127-120	Blower Base Weld Assembly		x	
20	127-146	Blower Base Weld Assembly			x
21	520-119	Coil Partition	x	x	x
22	140-133	Support Coil	x	x	x
23	134-098	Coil Shield	x	x	
23	134-099	Coil Shield			x
24	919-0002	Filter Rack W/Door	x	x	
24	919-0003	Filter Rack W/Door			x

Date: 2-07-92
Supersedes: 10-28-91

2110-856

Page: 2

UPFLOW FUNCTIONAL COMPONENT PARTS

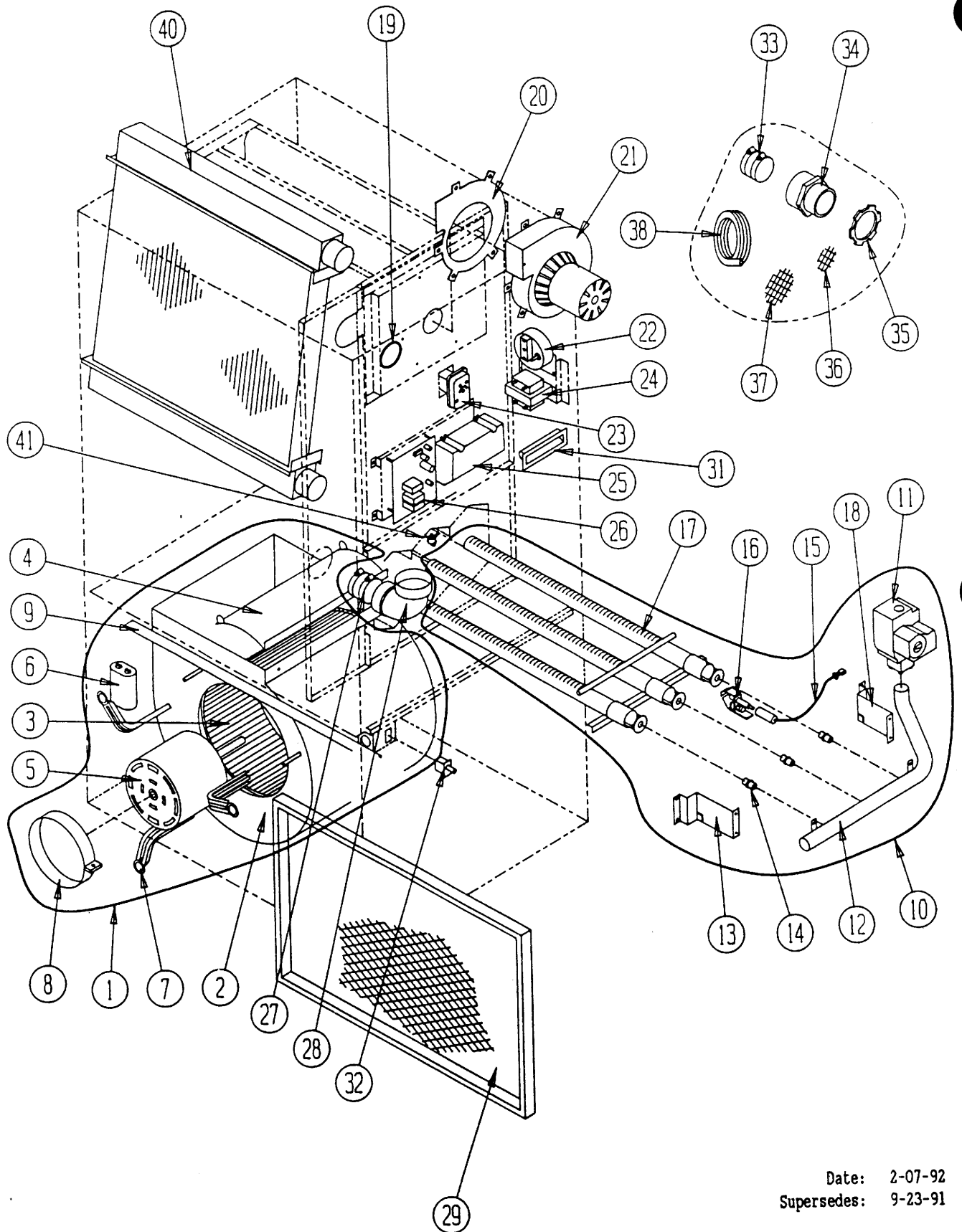

Date: 2-07-92
Supersedes: 9-23-91

2110-856

UPFLOW FUNCTIONAL COMPONENT PARTS LIST

Dwg. No.	Part No.	Description	C	C	C
			H	H	H
			0	0	1
			6	8	0
			0	0	0
			D	D	D
			3	4	6
			6	8	0
			B	B	B
1	900-100	Blower Assembly	x		
1	900-101	Blower Assembly		x	
1	900-102	Blower Assembly			x
2	151-085	Blower Housing	x		
2	151-074	Blower Housing		x	
2	151-084	Blower Housing			x
3	5152-013	Blower Wheel	x		
3	5152-059	Blower Wheel		x	
3	5152-061	Blower Wheel			x
4	144-127	Diffuser	x		
4	144-129	Diffuser		x	
4	144-131	Diffuser			x
5	8105-008	Motor	x		
5	8106-018	Motor		x	
5	8107-004	Motor			x
6	8552-002	Capacitor	x		
6	8552-004	Capacitor		x	
6	8552-026	Capacitor			x
7	8200-034	Motor Mount Leg	x	x	
7	8200-035	Motor Mount Leg			x
8	8200-033	Motor Mount Strap	x	x	x
9	104-796	Blower Angle	x		
9	104-792	Blower Angle		x	x
10	901-0083	Burner Assembly	x		
10	901-0082	Burner Assembly		x	
10	901-0084	Burner Assembly			x
11	5651-062	Gas Valve	x	x	x
12	5818-019	Gas Manifold	x		
12	5818-020	Gas Manifold		x	
12	5818-021	Gas Manifold			x
13	1127095	Left Manifold Bracket	x	x	x
14	9010-010	Gas Orifice Spud	x		
14	9010-046	Gas Orifice Spud		x	x
15	8600-009	Ignition Cable	x	x	x
16	8620-038	Pilot Assembly	x	x	x
17	9010-036	Burner Venturi	x		
17	9010-037	Burner Venturi		x	
17	9010-038	Burner Venturi			x
18	112X095	Right Manifold Bracket	x	x	x
19	1921-020	Silicone Die-Cut Gasket	x	x	x
20	1921-019	IDB Gasket	x	x	x
21	8620-033	Induced Draft Blwr Assy Kit	x	x	x

Dwg. No.	Parts No.	Description	C	C	C
			H	H	H
			0	0	1
			6	8	0
			0	0	0
			D	D	D
			3	4	6
			6	8	0
			B	B	B
22	8406-043	Pressure Switch	x		
22	8406-041	Pressure Switch			x
22	8406-042	Pressure Switch		x	
23	8620-032	Limit Assembly	x	x	x
24	8407-039	Transformer	x	x	x
25	5651-093	Ignition Module	x	x	x
26	8201-053	Blower Control	x	x	x
27	6093-007	"No Hub" Connector	x	x	x
28	6095-005	90 Degree Street Elbow	x	x	x
29	7003-004	16x25x1 Permanent	x	x	x
31	1171-025	Door Pull	x	x	x
32	8406-013	Door Switch	x	x	x
33	6093-008	"No Hub" Connector	x	x	x
34	6093-006	2" Male Adapter	x	x	x
35	8611-063	2" Conduit Lock Nut	x	x	x
36	7002-009	2" Bird Screen	x	x	x
37	7002-008	3" Bird Screen	x	x	x
38	5452-005-6000	Vinyl Drain Hose	x	x	x
*39	8620-031	Condensate Neutralizer	x	x	x
40	5055-001	Coil Assembly	x	x	x
41	8406-037	Flame Rollout Switch	x	x	x
	4046-108	Wiring Diagram	x	x	x
	8620-040	Pilot Gas Tube W/Fittings	x	x	x

*Not pictured.

Date: 5-04-92
Supersedes: 9-23-91

2110-856