

# REPLACEMENT PARTS MANUAL

## EXTRA HIGH EFFICIENCY II CONDENSING GAS FURNACE CC--SERIES

Manual 2110-857

Revision A

Date **1-10-90**

Supersedes 7-26-89

\*\*\*\*\*  
\* GENERAL NOTES \*  
\*\*\*\*\*

\*Revised and/or additional pages may be issued from time to time.  
\*A complete and current manual consists of pages dated as shown in the following index.

\*\*\*\*\*  
\*\* INDEX \*\*  
\*\*\*\*\*

<u>Page</u>	<u>Description</u>	<u>Page</u>	<u>Date</u>	<u>Supersedes</u>
Cabinet	Components--Exploded View	1	<b>1-10-90</b>	<b>7-26-89</b>
"	" -- Usage List	2	<b>1-10-90</b>	<b>7-26-89</b>
Functional	Components--Exploded View	3	7-26-89	
"	" -- Usage List	4	<b>1-10-90</b>	<b>7-26-89</b>

\*\*\*\*\*  
\*\*\* IMPORTANT \*\*\*  
\*\*\*\*\*

Contact the Installing and/or local Bard distributor for all parts requirements. Make sure you have the complete model and serial number available **from** the unit rating plate.

**BARD** MANUFACTURING COMPANY

BRYAN, OHIO 43506

DOWNFLOW CABINET COMPONENT PARTS

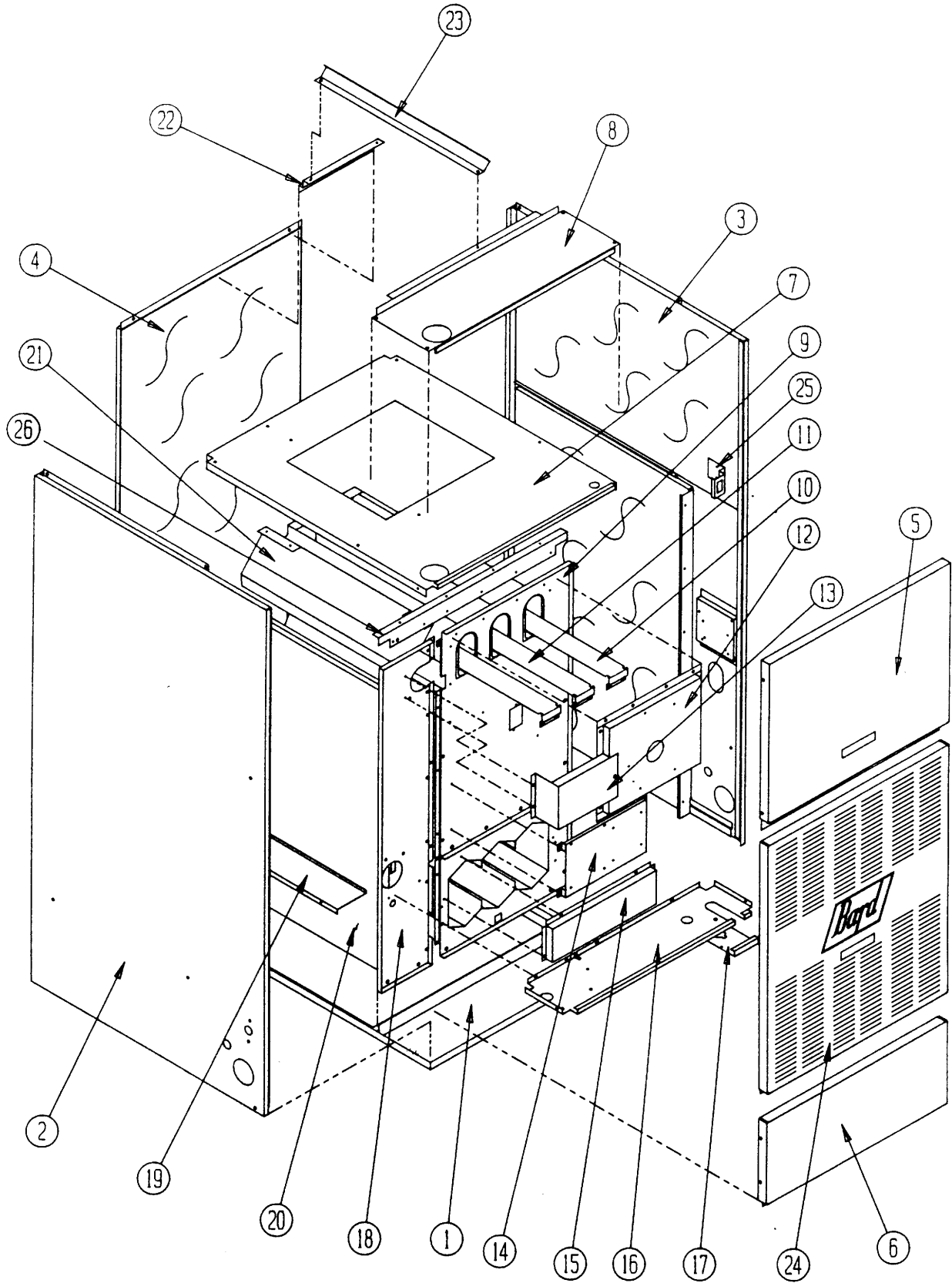

Date: 1-10-90  
Supersedes: 7-26-89

DOWNFLOW CABINET COMPONENT PARTS LIST

Dwg. No.	Part No.	Description	C	C	C
			0	0	1
			6	8	0
			0	0	0
			D	D	D
			3	4	4
			6	8	8
			A	A	A
1	127-166	Lower Base Assembly	x		
1	127-167	Lower Base Assembly		x	
1	127-163	Lower Base Assembly			x
2	501-198	Left Side Assembly	x	x	x
3	501-197	Right Side Assembly	x	x	x
4	508-018	Back Assembly	x		
4	508-019	Back Assembly		x	
4	508-073	Back Assembly			x
5	552-171	Blower Door Assembly	x		
5	552-172	Blower Door Assembly		x	
5	552-173	Blower Door Assembly			x
6	552-165	Burner Door Assembly	x		
6	552-166	Burner Door Assembly		x	
6	552-167	Burner Door Assembly			x
7	126-160	Blower Base Assembly	x		
7	126-161	Blower Base Assembly		x	
7	126-162	Blower Base Assembly			x
8	106-119	Top Fill	x		
8	106-120	Top Fill		x	
8	106-121	Top Fill			x
9	171-162	Heat Exchanger Assembly	x		
9	171-163	Heat Exchanger Assembly		x	
9	171-164	Heat Exchanger Assembly			x
10	168-002	Internal Flue Baffle	2	2	2
11	168-013	Internal Flue Baffle		1	2
12	913-0039	Collector Box Assembly	x		
12	913-0048	Collector Box Assembly		x	
12	913-0050	Collector Box Assembly			x
13	169-034	Transition Assembly	x		
13	169-035	Transition Assembly		x	
13	169-036	Transition Assembly			x
14	112-088	Module Bracket	x		
14	112-089	Module Bracket		x	x
15	168-003	Secondary Air Baffle	x		
15	168-008	Secondary Air Baffle		x	
15	168-010	Secondary Air Baffle			x
16	120-120	Burner Compartment Partition	x		
16	120-121	Burner Compartment Partition		x	
16	120-122	Burner Compartment Partition			x

Dwg. No.	Part No.	Description	C	C	C
			0	0	1
			6	8	0
			0	0	0
			D	D	D
			3	4	4
			6	8	8
			A	A	A
17	136-132	Manifold Fill Plate			x
17	136-131	Manifold Fill Plate	x	x	
18	520-119	Coil Partition	x	x	x
19	140-133	Coil Support	x	x	x
20	134-098	Internal Coil Partition	x	x	x
21	134-107	Coil Extension Partition	x	x	
22	130-023	Filter Support Bracket	x	x	x
23	130-062	Main Filter Support	x	x	x
24	152-168	Vestibule Door	x		
24	152-169	Vestibule Door		x	
24	152-170	Vestibule Door			x
25	112-094	Door Switch Bracket	x	x	x
26	104-821	Upper Heat Ex. Fill	x		
26	104-822	Upper Heat Ex. Fill		x	
26	104-823	Upper Heat Ex. Fill			x

Date: 1-10-90  
Supersedes: 7-26-89

DOWNFLOW FUNCTIONAL COMPONENT PARTS

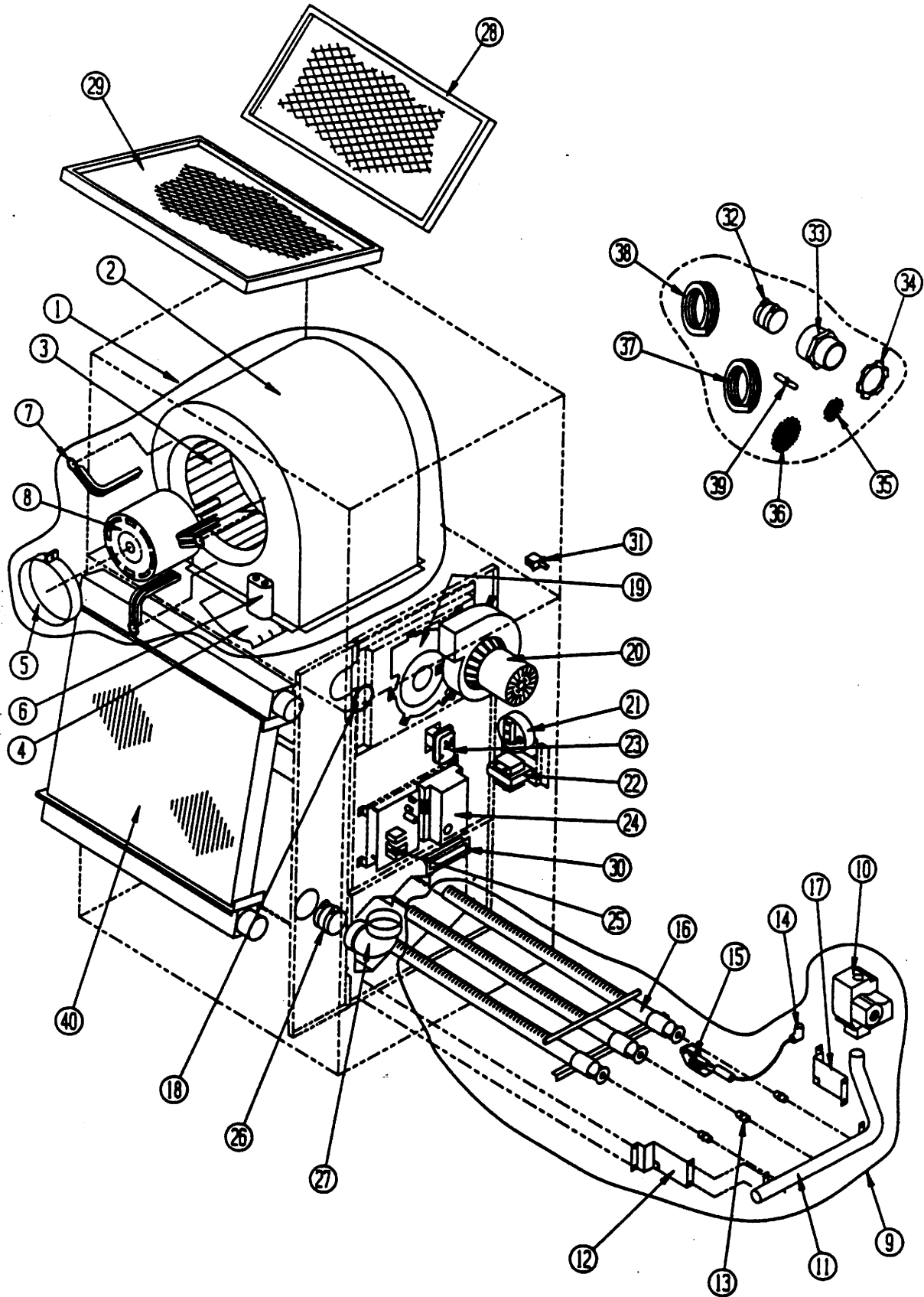

Date: 7-26-89  
Supersedes:

DOWNFLOW FUNCTIONAL COMPONENT PARTS LIST

Dwg. No.	Part No.	Description	C C O 6 0 D 3 6 A	C C O 8 0 D 4 8 A	C C O 1 0 D 4 8 A
1	900-150	Blower Assembly	x		
1	900-151	Blower Assembly		x	
1	900-152	Blower Assembly			x
2	151-089	Blower Housing Assembly	x		
2	151-077	Blower Housing Assembly		x	
2	151-090	Blower Housing Assembly			x
3	5152-013	Blower Wheel	x		
3	5152-059	Blower Wheel		x	
3	5152-061	Blower Wheel			x
4	144-127	Diffuser	x		
4	144-129	Diffuser		x	
4	144-131	Diffuser			x
5	8200-033	Motor Mount Band	x	x	x
6	8552-002	Capacitor	x		
6	8552-004	Capacitor		x	
6	8552-006	Capacitor			x
7	8200-034	Motor Mount Arm	3	3	3
8	8105-008	Motor	x		
8	8106-018	Motor		x	
8	8107-004	Motor			x
9	901-0083	Burner Assembly	x		
9	901-0082	Burner Assembly		x	
9	901-0084	Burner Assembly			x
10	5651-062	Gas Valve	x	x	x
11	5818-019	Manifold 2 Section	x		
11	5818-020	Manifold 3 Section		x	
11	5818-021	Manifold 4 Section			x
12	112Y095	Left Manifold Bracket	x	x	x
13	9010-010	Gas Orifice #38	2		
13	9010-046	Gas Orifice #41		3	4
14	8600-008	Ignition Wire	x	x	x
15	8554-009	Pilot Assembly	x	x	x
16	9010-036	Burner 2 Section	x		
16	9010-037	Burner 3 Section		x	
16	9010-038	Burner 4 Section			x
17	112X095	Right Manifold Bracket	x	x	x
18	1921-020	Silicone Gasket	x	x	x
19	1921-019	IDB Gasket	x	x	x
20	8620-033	Induced Draft Blwr Assy Kit	x	x	x

Dwg. No.	Part No.	Description	C C O 6 0 D 3 6 A	C C O 8 0 D 4 8 A	C C O 1 0 D 4 8 A
21	8406-041	Pressure Switch			
21	8406-042	Pressure Switch	x	x	x
22	8407-039	Transformer 40VA	x	x	x
23	8620-032	Limit Switch	x	x	x
24	5651-060	Ignition Module	x	x	x
25	8201-053	Blower Control	x	x	x
26	6093-007	"No-Hub" Connector	x	x	x
27	6095-005	Street Ell 90 degree	x	x	x
28	7003-001	Permanent Filter 10 x 20 x 1	2	1	1
29	7003-003	Permanent Filter 15 x 20 x 1		1	1
30	1171-025	Flush Door Pull	2	2	2
31	8406-013	Door Switch	x	x	x
32	6093-008	"No-Hub" Connector	x	x	x
33	6093-006	Male Adapter 2"	x	x	x
34	8611-063	2" Locknut	x	x	x
35	7002-009	2" Bird Screen	3	3	3
36	7002-008	3" Bird Screen		3	3
37	5452-005	Vinyl Tubing	x	x	x
38	5452-006	Silicone Tubing	x	x	x
39	6093-009	Hose Coupling	x	x	x
40	5055-001	Coil Assembly	x	x	x

Date: 1-10-90  
Supersedes: 7-26-89