

REPLACEMENT PARTS MANUAL

UPFLOW GAS FURNACE

MODELS: DCH036D30A, DCH050D30A, DCH065D36A,  
DCH080D48A, DCH095D60A, DCH110D60A

Manual 2110-859

Revision C

Date 06-16-93

Supersedes 06-09-93

\*\*\*\*\*  
\* GENERAL NOTES \*  
\*\*\*\*\*

\*Revised and/or additional pages may be issued from time to time.  
\*A complete and current manual consists of pages dated as shown in the following index.

\*\*\*\*\*  
\*\* INDEX \*\*  
\*\*\*\*\*

Page	Description	Page	Date	Supersedes
	Cabinet Components-- Exploded View	1	06-16-93	06-12-92
"	" --Usage List	2	06-09-93	06-12-92
"	" --Usage List	3	06-09-93	06-12-92
Functional	Components-- Exploded " View	4	06-16-93	06-09-93
"	" --Usage List	5	06-09-93	06-12-92
"	" --Usage List	6	06-09-93	

\*\*\*\*\*  
\*\*\* IMPORTANT \*\*\*  
\*\*\*\*\*

Contact the Installing and/or local Bard distributor for all parts requirements. Make sure you have the complete model and serial number available from the unit rating plate.

CABINET COMPONENTS

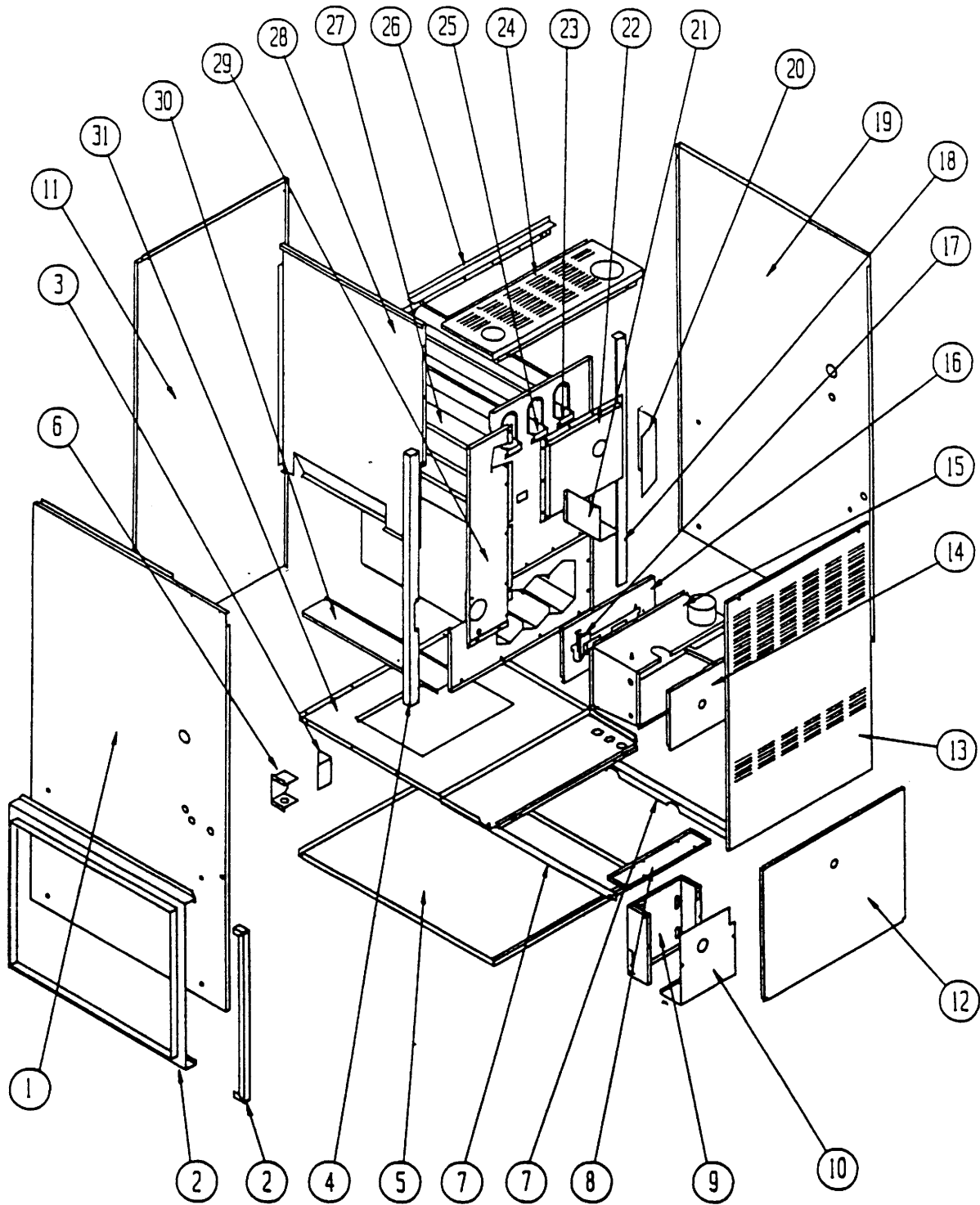

MODELS DCH080, DCH095 Shown

Date: 6-16-93  
Supersedes: 6-12-92

2110-859  
Page: 1

CABINET COMPONENTS

Dwg. No.	Part No.	Description	D	D	D	D	D	D
			C	C	C	C	C	C
			H	H	H	H	H	H
			0	0	0	0	0	0
			3	5	6	8	9	1
			6	0	5	0	5	0
			D	D	D	D	D	D
			3	3	3	4	6	6
			0	0	6	8	0	0
			A	A	A	A	A	A
1	500-231	Left Side Assembly	X	X	X	X	X	X
2	FR21	Filter Rack (1)	X	X	X	X	X	X
3	132-107	Junction Box Door	X	X	X	X	X	X
4	104-855	Left Side Angle	X	X	X	X	X	X
5	126-200	Lower Base	X	X	X			
5	126-205	Lower Base				X	X	
5	126-206	Lower Base						X
6	116-130	Junction Box	X	X	X	X	X	X
7	104-857	Blower Angle	X	X	X		X	
7	104-863	Blower Angle				X		
7	104-894	Blower Angle						X
8	116-125	Control Panel Bracket	X	X	X			
8	116-132	Control Panel Bracket				X		
8	116-133	Control Panel Bracket					X	
8	116-152	Control Panel Bracket						X
9	116-126	Control Panel	X	X	X	X	X	X
10	132-105	Control Panel Cover	X	X	X	X	X	X
11	508-090	Back	X	X	X			
11	508-093	Back				X	X	
11	508-094	Back Assembly						X
12	S152-210	Blower Door	X	X	X			
12	S152-214	Blower Door				X	X	
12	S152-215	Blower Door						X
13	S152-209	Vestibule Door	X	X	X			
13	S152-216	Vestibule Door				X	X	
13	S152-217	Vestibule Door						X
14	S168-052	Burner Box Cover	X	X	X			
14	S168-058	Burner Box Cover				X	X	
14	S168-063	Burner Box Cover						X
15	913-0066	Burner Box	X	X	X			
15	913-0067	Burner Box				X	X	
15	913-0070	Burner Box						X
16	168-050	Secondary Air Restrictor		X	X			
16	168-055	Secondary Air Restrictor				X	X	
16	168-060	Secondary Air Restrictor						X
16	168-068	Secondary Air Restrictor	X					
17	112-147	Ignitor Bracket	X	X	X	X	X	X
18	104-856	Right Side Angle	X	X	X	X	X	X
19	500-230	Right Side Assembly	X	X	X	X	X	X
20	134-121	Intake Air Shield	X	X	X			
21	134-120	Vent Air Shield	X	X	X	X	X	X

(1) Includes 16 x 25 permanent filter.

Date: 06-09-93  
Supersedes: 06-12-92

CABINET COMPONENTS

Dwg. No.	Part No.	Description	D	D	D	D	D	D
			C	C	C	C	C	C
			H	H	H	H	H	H
			0	0	0	0	0	1
			3	5	6	8	9	1
			6	0	5	0	5	0
			D	D	D	D	D	D
			3	3	3	4	6	6
			0	0	6	8	0	0
			A	A	A	A	A	A
22	168-054	Collector Box		x	x			
22	168-059	Collector Box				x	x	
22	S168-054	Collector Box		x	x			
22	S168-059	Collector Box				x	x	
22	S168-064	Collector Box						x
22	S168-066	Collector Box	x					
23	168-002	Flue Baffle		2	2	3	3	2
24	106-131	Top Fill		x	x			
24	106-135	Top Fill				x	x	
24	106-136	Top Fill						x
25	168-013	Flue Baffle	1					2
26	140-134	Plenum Support		x	x			
26	140-135	Plenum Support				x	x	
27	171-193	Heat Exchanger		x	x			
27	171-194	Heat Exchanger				x	x	
27	171-195	Heat Exchanger Assembly						x
27	171-200	Heat Exchanger Assembly	x					
28	S134-099	Internal Coil Partition		x	x	x	x	
28	S134-136	Internal Coil Partition	x					x
29	520-183	Coil Partition Assembly		x	x	x	x	
29	520-227	Coil Partition	x					x
30	140-133	Coil Support	x	x	x	x	x	x
31	127-201	Blower Base Assembly	x	x	x			
31	127-207	Blower Base Assembly				x	x	
31	S126-208	Blower Base Assembly						x

Date: 06-09-93  
Supersedes: 06-12-93

FUNCTIONAL COMPONENTS

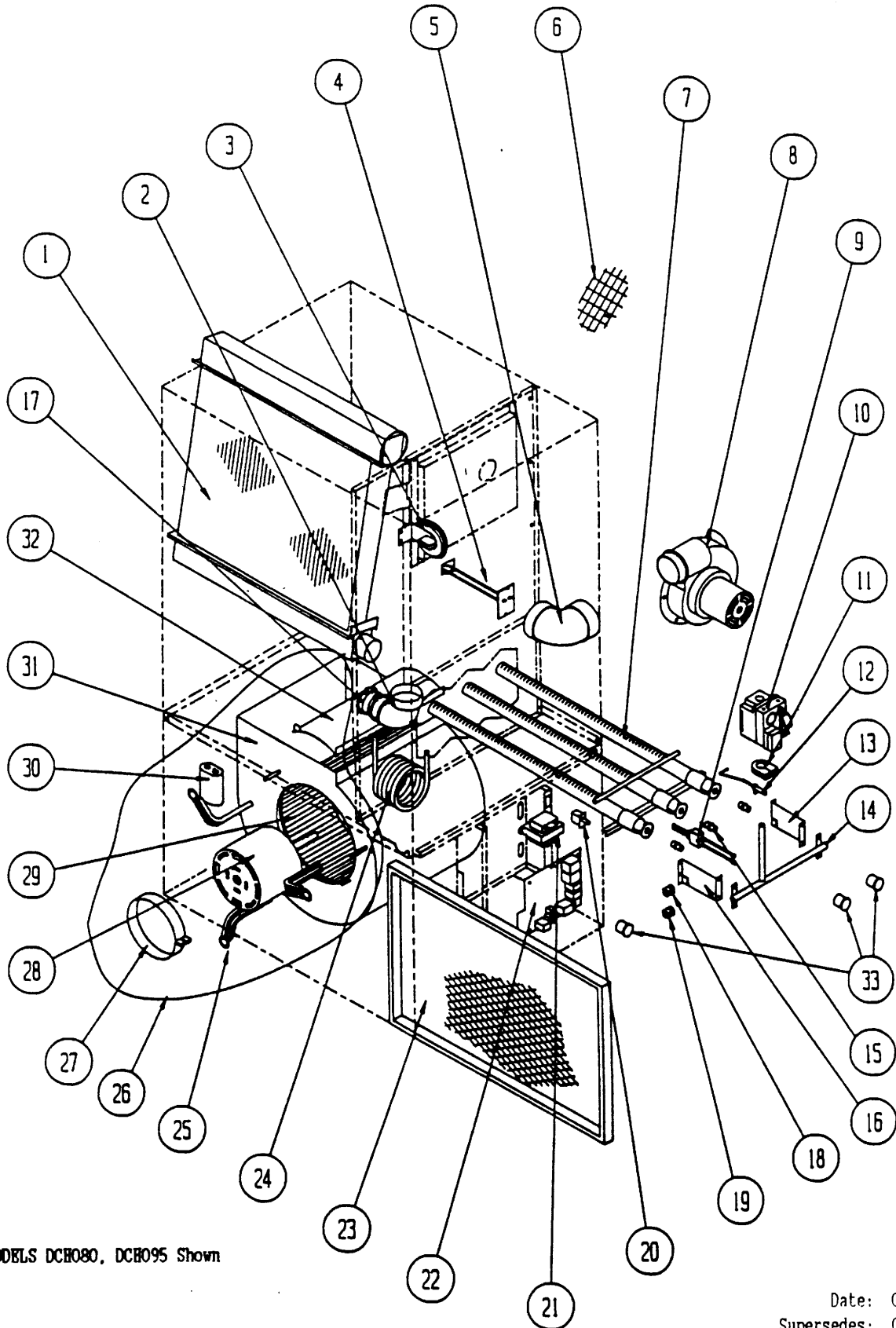

MODELS DC8080, DC8095 Shown

Date: 06-16-93  
Supersedes: 06-09-93

2110-859  
Page: 4

FUNCTIONAL COMPONENTS

Dwg. No.	Part No.	Description	D	D	D	D	D	D
			C	C	C	C	C	C
			H	H	H	H	H	H
			O	O	O	O	O	O
			3	5	6	8	9	1
			6	0	5	0	5	0
			D	D	D	D	D	D
			3	3	3	4	6	6
			0	0	6	8	0	0
			A	A	A	A	A	A
1	5055-002	Coil Assembly		x		x		
1	5055-003	Coil Assembly	x		x		x	x
2	6095-005	2" Street Elbow--PVC	x	x	x	x	x	
2	6095-008	2" Street Elbow--ABS						x
3	8406-068	Pressure Switch		x		x		
3	8406-069	Pressure Switch			x			
3	8406-070	Pressure Switch	x				x	x
4	8402-064	Limit Control				x	x	
4	8402-067	Limit Control			x			x
4	8402-068	Limit Control		x				
4	8402-079	Limit Control	x					
5	6095-006	High Temperature Elbow	x	x	x	x	x	x
6	7002-022	2.375" Bird Screen	2	2	2			
6	7002-023	2.875" Bird Screen	2	2	2			
6	7002-024	3.500" Bird Screen	2	2	2	2	2	2
7	9010-060	Burner	x					
7	9010-061	Burner		x	x			
7	9010-062	Burner				x	x	
7	9010-063	Burner						x
8	8620-068	Induced Draft Blower Assembly	x	x	x	x	x	x
9	8553-003	Ignitor	x	x	x	x	x	x
10	5651-083	Gas Valve	x	x	x			
10	5651-089	Gas Valve				x	x	
10	5651-106	Gas Valve						x
11	5451-017	Manifold Grommet	x	x	x	x	x	x
12	8554-016	Sensor		x	x	x	x	x
12	8554-018	Sensor	x					
13	112X148	Right Manifold Bracket	x	x	x	x	x	x
14	5818-028	Gas Manifold		x	x			
14	5818-029	Gas Manifold				x	x	
14	5818-030	Gas Manifold						x
14	5818-031	Gas Manifold	x					
15	9010-010	Gas Orifice #38						x
15	9010-043	Gas Orifice #36			x			
15	9010-052	Gas Orifice 2.70 MM					x	
15	9010-053	Gas Orifice #33	x					
15	9010-054	Gas Orifice 3/32"		x				
15	9010-057	Gas Orifice 2.45MM				x		
16	112Y148	Left Manifold Bracket	x	x	x	x	x	x
17	6093-007	No-Hub Connector	x	x	x	x	x	x
18	8611-073	Single Terminal Bushing	x	x	x	x	x	x
19	8611-074	Double Terminal Bushing	x	x	x	x	x	x

Date: 06-09-93  
Supersedes: 06-12-92

FUNCTIONAL COMPONENTS

Dwg. No.	Part No.	Description	D	D	D	D	D	D
			C	C	C	C	C	C
			H	H	H	H	H	H
			0	0	0	0	0	1
			3	5	6	8	9	1
			6	0	5	0	5	0
			D	D	D	D	D	D
			3	3	3	4	6	6
			0	0	6	8	0	0
			A	A	A	A	A	A
20	8406-047	Door Switch	x	x	x	x	x	x
21	8407-039	Transformer	x	x	x	x	x	x
22	5651-084	Furnace Control	x	x	x	x	x	x
23	7003-004	16 x 25 Permanent Filter	x	x	x	x	x	x
24	5452-005-6000	Vinyl Drain Hose	x	x	x	x	x	x
25	8200-034	Motor Mount Arm	3	3	3	3		
25	8200-035	Motor Mount Arm					3	3
26	900-173	Blower Assembly			x			
26	900-174	Blower Assembly	x	x				
26	900-175	Blower Assembly				x		
26	900-176	Blower Assembly					x	
26	900-177	Blower Assembly						x
27	8200-033	Motor Mount Band	x	x	x	x	x	x
28	8105-037	1/3 HP Motor 115V			x			
28	8105-038	1/3 HP Motor 115V	x	x				
28	8106-028	1/2 HP Motor 115V				x		
28	8107-005	3/4 HP Motor 115V					x	
28	8107-006	3/4 HP Motor 115V						x
29	5152-005	Blower Wheel	x	x				
29	5152-013	Blower Wheel			x			
29	5152-050 <del>9</del>	Blower Wheel				x	x	
29	5152-053	Blower Wheel						
29	5152-072	Blower Wheel						x
29	5152-073	Blower Wheel						x
30	8552-002	Capacitor 5 MFD 370V	x	x	x			
30	8552-004	Capacitor 7 MFD 370V				x		
30	8552-026	Capacitor 15 MFD 370V					x	x
31	151-082	Blower Housing				x		
31	151-085	Blower Housing	x	x	x			
31	151-102	Blower Housing						x
31	151-103	Blower Housing						x
31	5152-050	Blower Housing (1)					x	
32	144-127	Diffuser	x	x	x			
32	144-129	Diffuser				x		
32	144-167	Diffuser						2
32	(1) N/A	Diffuser					x	
33	8611-075	Sight Glass	3	3	3	3	3	3
33	112-158	Blower Assembly Bracket						2

(1) Drawing No. 31 part No. 5152-050 includes housing, diffuser, and wheel part No. 5152-053.

Date: 06-09-93  
Supersedes: