

REPLACEMENT PARTS MANUAL

DOWNFLOW GAS FURNACE

MODELS : DCC050D30A, DCC065D36B,
DCC080D48B, DCC095D48B

Manual 2110-866

Revision B

Date 04-27-94

Supersedes 06-16-93

* GENERAL NOTES *

*Revised and/or additional pages may be issued from time to time.
*A complete and current manual consists of pages dated as shown in the following index.

** INDEX **

<u>Page</u>	<u>Description</u>	<u>Page</u>	<u>Date</u>	<u>Supersedes</u>
	Cabinet Components--Exploded View	1	04-27-94	06-09-93
	--Usage List	2	04-27-94	06-09-93
	Functional Components--Exploded View	3	06-09-93	
	" " --Usage List	4	04-27-94	06-09-93
	" " --Usage List	5	04-27-94	06-09-93

*** IMPORTANT ***

Contact the installing and/or local Bard distributor for all parts requirements. Make sure you have the complete model and serial number available from the unit rating plate.

CABINET COMPONENTS

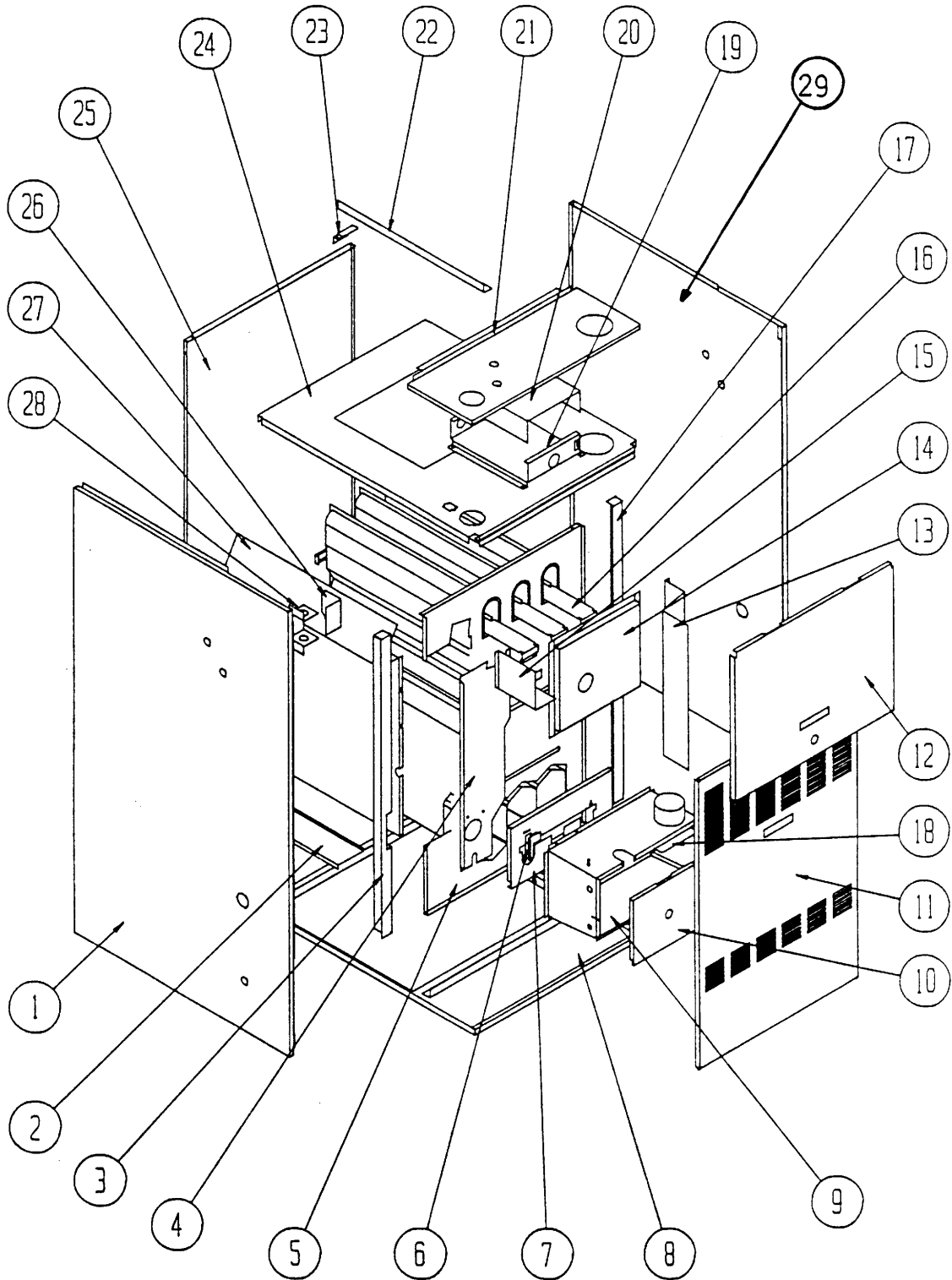

Date: 04-27-94
Supersedes: 06-09-93

CABINET COMPONENTS

Dwg. No.	Part No.	Description	D C C O 5 0 D 3 0 A	D C C O 6 5 D 3 6 B	D C C O 8 0 D 4 8 B	D C C O 9 5 D 4 8 B
1	500-269	Left Side	X	X	X	X
2	140-133	Coil Support	X	X	X	X
3	104-885	Left Side Angle	X	X	X	X
4	520-227	Coil Partition Assembly	X	X	X	X
5	171-198	Heat Exchanger Assembly	X	X		
5	171-199	Heat Exchanger Assembly			X	X
6	112-147	Ignitor Bracket	X	X	X	X
7	168-050	Secondary Air Restrictor	X	X		
7	168-055	Secondary Air Restrictor			X	X
8	126-217	Lower Base Assembly	X	X		
8	126-218	Lower Base Assembly			X	X
9	913-0066	Burner Box	X	X		
9	913-0067	Burner Box			X	X
10	S168-052	Burner Box Cover	X	X		
10	S168-058	Burner Box Cover			X	X
11	S152-227	Vestibule Door	X	X		
11	S152-228	Vestibule Door			X	X
12	S152-225	Blower Door	X	X		
12	S152-226	Blower Door			X	X
13	134-121	Intake Air Shield Assembly	X	X		
13	S134-133	Intake Air Shield Assembly			X	X
14	S168-054	Collector Box Assembly	X	X		
14	S168-059	Collector Box Assembly			X	X
15	134-120	Vent Air Shield	X	X	X	X
16	168-080	Flue Baffle	2	2	3	3
17	104-886	Right Side Angle	X	X	X	X
18	134-119	Combustion Air Diffuser	X	X	X	X
19	116-146	Control Panel	X	X	X	X
20	132-118	Control Panel Cover	X	X	X	X
21	106-143	Top Fill	X	X		
21	106-144	Top Fill			X	X
22	130-098	Filter Support Angle	X	X	X	X
23	130-097	Filter Support Bracket	X	X	X	X
24	126-219	Blower Base	X	X		
24	126-220	Blower Base			X	X
25	508-099	Back Assembly	X	X		
25	508-100	Back Assembly			X	X
26	132-117	Junction Box Door	X	X	X	X
27	134-132	Internal Coil Air Deflector	X	X	X	X
28	116-145	Junction Box	X	X	X	X
29	500-268	Right Side	X	X	X	X

Date: 04-27-94
Supersedes: 06-09-93

FUNCTIONAL COMPONENTS

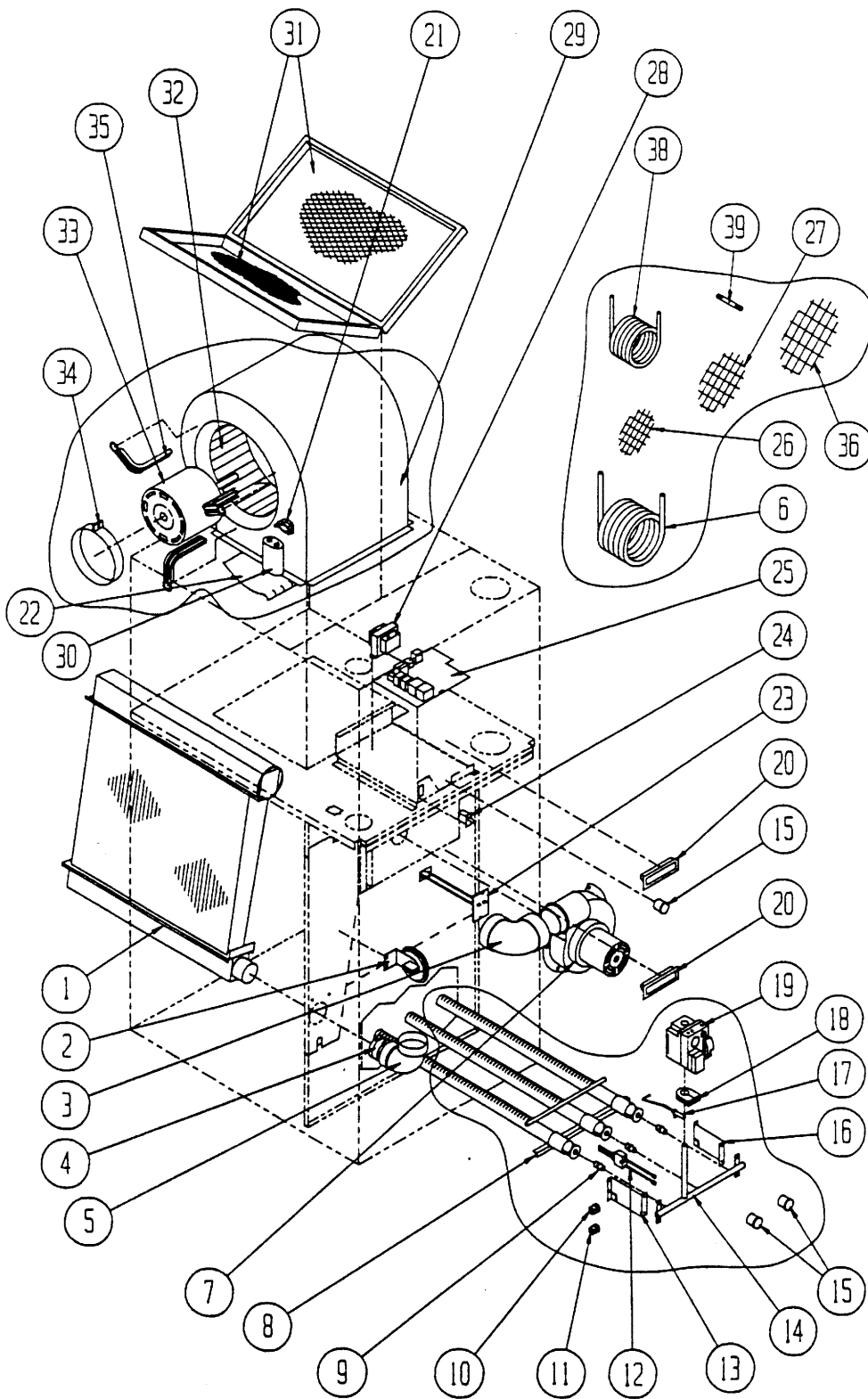

Date: 06-09-93
Supersedes:

FUNCTIONAL COMPONENTS

Dwg. No.	Part No.	Description	D	D	D	D
			C	C	C	C
			0	0	0	0
			5	6	8	9
			0	5	0	5
			D	D	D	D
			3	3	4	4
			0	6	8	8
			A	B	B	B
1	5055-002	Coil Assembly	x			
1	5055-003	Coil Assembly		x		x
1	5055-004	Coil Assembly			x	
2	8406-068	Pressure Switch	x			
2	8406-070	Pressure Switch			x	x
2	8406-069	Pressure Switch		x		
3	6095-006	High Temperature Elbow	x	x	x	x
4	6093-007	"No Hub" Connector	x	x	x	x
5	6095-008	2" ABS Street Elbow	x	x	x	x
6	5452-005-3000	Vinyl Drain Hose	x	x	x	x
7	8620-084	Combustion Air Blower	x	x	x	x
8	9010-061	2 Section Burner	x	x		
8	9010-062	3 Section Burner			x	x
9	9010-043	Gas Orifice		2		
9	9010-054	Gas Orifice	2			
9	9010-057	Gas Orifice			3	
9	9010-052	Gas Orifice				3
10	8611-073	Single Terminal Bushing	x	x	x	x
11	8611-074	Double Terminal Bushing	x	x	x	x
12	8553-003	Ignitor	x	x	x	x
13	112Y148	Left Manifold Bracket	x	x	x	x
14	5818-028	Gas Manifold	x	x		
14	5818-029	Gas Manifold			x	x
15	8611-075	Sight Glass	3	3	3	3
16	112X148	Right Manifold Bracket	x	x	x	x
17	8554-016	Sensor	x	x	x	x
18	5451-017	Manifold Grommet	x	x	x	x
19	5651-083	Gas Valve	x	x		
19	5651-089	Gas Valve			x	x
20	1171-025	Door Pull	x	x	x	x
21	8402-050	Upper Limit Control	x	x	x	x
22	144-127	Diffuser	x	x		
22	144-129	Diffuser			x	x
23	8402-077	Primary Limit Control	x			
23	8402-078	Primary Limit Control		x	x	
23	8402-067	Primary Limit Control				x
24	8406-047	Secondary Limit Control	x	x	x	x
25	5651-084	Furnace Control	x	x	x	x
26	7002-022	2.375" Diameter Bird Screen	x	x		
27	7002-023	2.875" Diameter Bird Screen	x	x		
28	8407-039	Transformer	x	x	x	x
29	151-089	Blower Housing	x	x		
29	151-077	Blower Housing			x	x

Date: 04-27-94
Supersedes: 06-09-93

FUNCTIONAL COMPONENTS

Dwg. No.	Part No.	Description	D	D	D	D
			C	C	C	C
			O	O	O	O
			5	6	8	9
			0	5	0	5
			D	D	D	D
			3	3	4	4
			0	6	8	8
			A	B	B	B
30	8552-002	Capacitor 5 MFD 370V	x	x		
30	8552-004	Capacitor 7-1/2 MFD 370V			x	x
31	7003-001	10x20x1 Permanent Filter	2	2		
31	7003-037	12x20x1 Permanent Filter			2	2
32	5152-005	Blower Wheel 9-8DD	x			
32	5152-013	Blower Wheel 10-8DD		x		
32	5152-014	Blower Wheel 10-10DD			x	x
33	8200-034	Motor Mount Arm	3	3	3	3
34	8200-033	Motor Mount Band	x	x	x	x
35	8105-038	1/3 HP Motor 115V	x			
35	8105-037	1/3 HP Motor 115V		x		
35	8106-028	1/2 HP Motor 115V			x	x
36	7002-024	3/500" Diameter Bird Screen	x	x	x	x
37	900-187	Blower Assembly			x	x
37	900-188	Blower Assembly	x			
37	900-189	Blower Assembly		x		
38	5452-006-3600	Silicone Drain Tubing	x	x	x	x
39	6093-009	Hose Coupling	x	x	x	x
	4046-122	Wiring Diagram	x	x	x	x

Date: 04-27
 Supersedes: 66-09