

Replacement Parts Manual

TSF-80 Upflow Gas Furnace

Models: TU044, TU066, TU088,
TU110, TU132

General Notes

- Revised and/or additional pages may be issued from time to time.
- A complete and current manual consists of pages shown in the following contents section.

Important

- Contact the installing and/or local Bard distributor for all parts requirements. Make sure you have the complete model and serial number available from the unit rating plates.

Contents

Description	Page
Cabinet Components	
• Exploded View	1
• Usage List	2-3
Functional Components	
• Exploded View	5
• Usage List	6
Wire Components	
• Usage List	7
• Exploded View	7



BARD MANUFACTURING COMPANY
Bryan, Ohio 43506

Since 1914... Moving ahead, just as planned.

Manual: 211 O-873A
Tab:
Date: 08-23-96

Cabinet Components

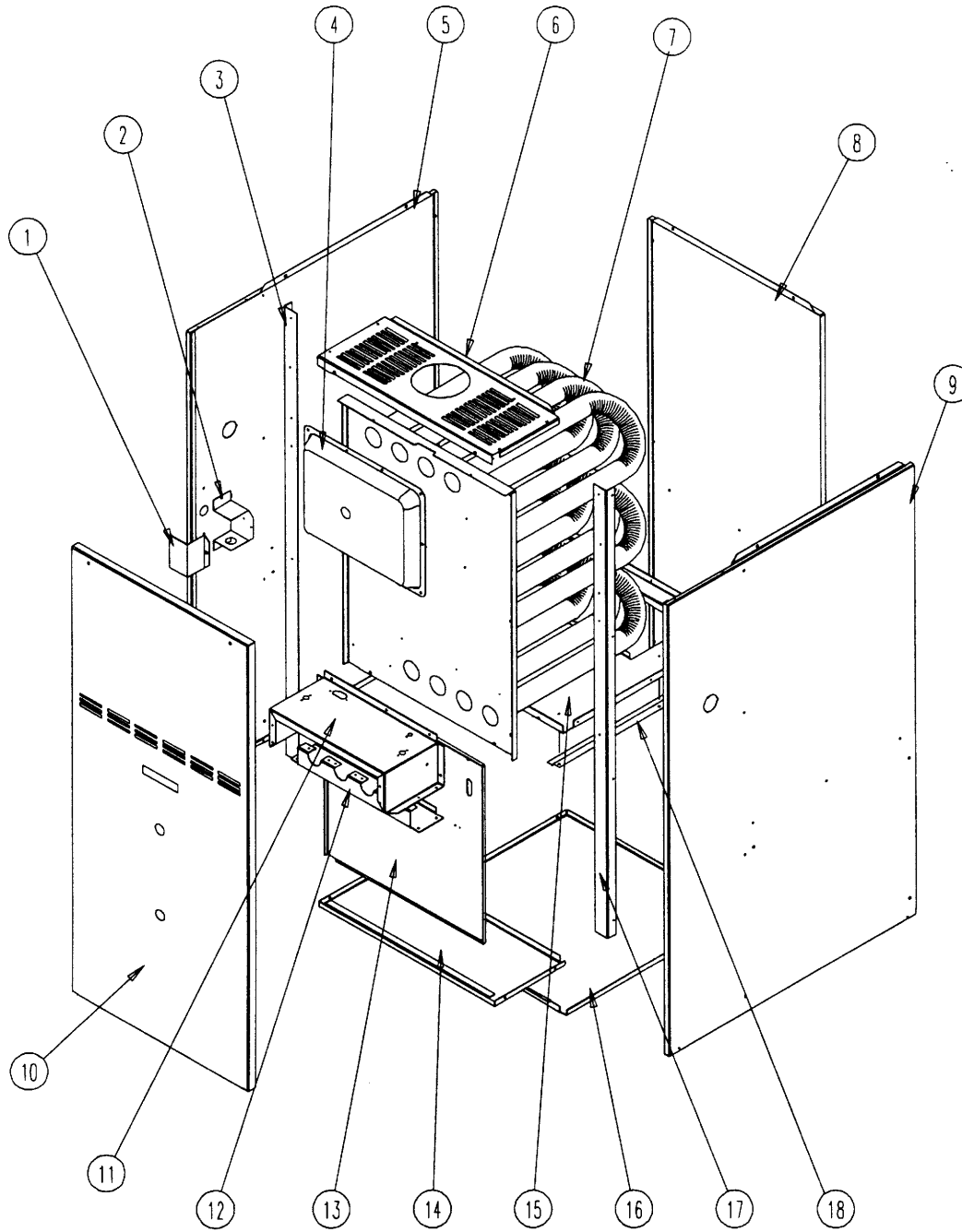

SEXP-225

Cabinet Components

Drawing No.	Part No.	Description	TU044	TU066	TU088	TU110	TU132
1	132-107	Junction Box Cover	•	•	•	•	•
2	116-174	Junction Box	•	•	•	•	•
3	104Y953	Left Side Angle	•	•	•	•	•
4	S168-096	Collector Box Assembly	•				
4	S168-097	Collector Box Assembly		•			
4	S168-098	Collector Box Assembly			•		
4	S168-099	Collector Box Assembly				•	
4	S168-100	Collector Box Assembly					•
5	5100-304	Left Side Assembly	•	•	•	•	•
6	106-175	Top Fill	•	•			
6	106-177	Top Fill		•			
6	106-165	Top Fill			•		
6	106-179	Top Fill				•	
6	106-181	Top Fill					•
7	S170-229	Heat Exchanger Assembly	•				
7	S170-230	Heat Exchanger Assembly		•			
7	S170-231	Heat Exchanger Assembly			•		
7	S170-232	Heat Exchanger Assembly				•	
7	S170-233	Heat Exchanger Assembly					•
8	S108-116	Back Assembly	•				
8	S108-117	Back Assembly		•			
8	S108-118	Back Assembly			•		
8	S108-119	Back Assembly				•	
8	S108-120	Back Assembly					•
9	S100-303	Right Side Assembly	•	•	•	•	•
10	S152-255	Vestibule Door Assembly	•				
10	S152-257	Vestibule Door Assembly		•			
10	S152-251	Vestibule Door Assembly			•		
10	S152-259	Vestibule Door Assembly				•	
10	S152-261	Vestibule Door Assembly					•
11	162-034	Burner Box	•				
11	162-036	Burner Box		•			
11	162-032	Burner Box			•		
11	162-038	Burner Box				•	
11	162-040	Burner Box					•
12	162-033	Burner Bracket	•				
12	162-035	Burner Bracket		•			
12	162-031	Burner Bracket			•		
12	162-037	Burner Bracket				•	
12	162-039	Burner Bracket					•
13	S152-254	Blower Door Assembly	•				
13	S152-256	Blower Door Assembly		•			
13	S152-250	Blower Door Assembly			•		
13	S152-258	Blower Door Assembly				•	
13	S152-260	Blower Door Assembly					•
14	106-176	Bottom Fill	•				
14	106-178	Bottom Fill		•			
14	106-166	Bottom Fill			•		
14	106-180	Bottom Fill				•	
14	106-182	Bottom Fill					•

Cabinet Components

Drawing			TU044	TU066	TU088	TU110	TU132
No.	Part No.	Description					
15	S126-260	Blower Base Assembly	•				
15	S126-261	Blower Base Assembly		•			
15	S126-253	Blower Base Assembly			•		
15	S126-262	Blower Base Assembly				•	
15	S126-263	Blower Base Assembly					•
16	136-332	Return Fill Plate	•				
16	136-333	Return Fill Plate		•			
16	136-334	Return Fill Plate			•		
16	136-335	Return Fill Plate				•	
16	136-336	Return Fill Plate					•
17	104X953	Right Side Angle	•	•	•	•	•
18	102-412	Blower Base Offset	•	•	•	•	•

Functional Components

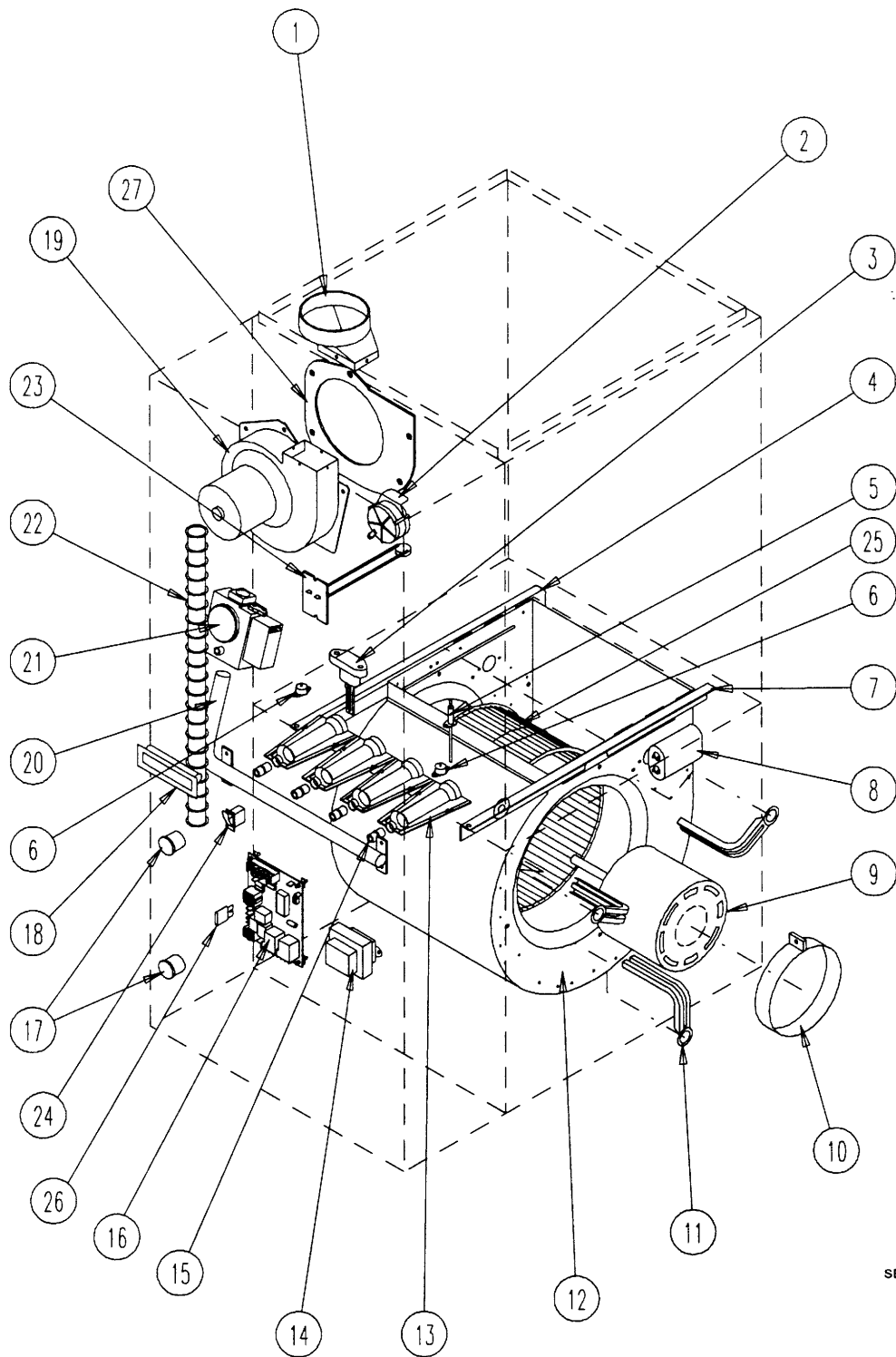

SEXP-226

Functional Components

Drawing No.	Part Number	Description	TU044	TU066	TU088	TU110	TU132
1	5809-013	3" Inducer Transition	•				
1	5809-014	4" Inducer Transition		•	•	•	•
2	8406-081	Pressure Switch .55" Setpoint ①	•				
2	8406-075	Pressure Switch .65" Setpoint ①		•	•	•	•
3	8620-133	Hot Surface Ignitor	•	•	•	•	•
4	104Y951	Left Blower Angle	•	•	•	•	•
5	8554-019	Flame Sensor	•	•	•	•	•
6	8406-036	Flame Rollout Switch	2	2	2	2	2
7	104X951	Right Blower Angle	•	•	•	•	•
8	8552-002	Capacitor 5/370	•	•			
8	8552-004	Capacitor 7.5/370			•		
8	8552-026	Capacitor 15/370				•	•
9	8105-038	Motor 1/3 H.P.	•				
9	8105-041	Motor 1/3 H.P.		•			
9	8106-033	Motor 1/2 H.P.			•		
9	8107-007	Motor 3/4 H.P.				•	•
10	8200-033	Motor Mount Band	•	•	•	•	•
11	8200-036	Motor Mount Arm	3	3			
11	8200-034	Motor Mount Arm			3		
11	8200-035	Motor Mount Arm				3	3
12	151-109	Blower Housing Assembly	•				
12	151-085	Blower Housing Assembly		•			
12	151-082	Blower Housing Assembly			•		
12	5152-050 ②	Blower Housing Assembly				•	•
13	9010-074	Inshot Burner	2	3	4	5	6
14	8407-045	Transformer 120/24V 40VA	•	•	•	•	•
15	9010-068	Gas Orifice #43 Drill	2	3	4	5	6
16	5651-123 144	Integrated Furnace Control	•	•	•	•	•
17	8611-075	Clear Sight Glass	2	2	2	2	2
18	1171-025	Door Pull	•	•	•	•	•
19	8109-009	Induced Draft Blower	•	•	•	•	•
20	5818-033	Gas Manifold	•				
20	5818-034	Gas Manifold		•			
20	5818-035	Gas Manifold			•		
20	5818-036	Gas Manifold				•	
20	5818-037	Gas Manifold					•
21	5651-136	Gas Valve	•	•	•	•	•
22	8611-089-1400	Plastic Wire Channel	•	•	•	•	•
23	8402-078	Primary Limit Control	•	•			
23	8402-089	Primary Limit Control			•	•	•
24	8406-076	Door Switch	•	•	•	•	•
25	5152-073	Blower Wheel	•				
25	5152-013	Blower Wheel		•			
25	5152-059	Blower Wheel			•		
25	5152-053	Blower Wheel				•	•
26	8614-045	3 Amp Fuse	•	•	•	•	•
27	1921-039	Induced Draft Blower Gasket	•	•	•	•	•
	5452-008-1200	Pressure Switch Tubing	•	•	•	•	•

① Setpoints shown are nominal cutout (open on pressure fall) ratings and have ± .05 tolerance.

② Includes: Wheel P/N 5152-053, Housing and diffuser

Wire Components

Drawing No.	Part No.	Description	TU044	TU066	TU088	TU110	TU132
1	3000-1028	Wire Harness	•	•	•	•	•
2	3000-1029	Wire Harness	•	•	•	•	•
3	3000-1031	Wire Harness	•	•	•	•	•
4	3000-1030	Wire Harness	•	•	•	•	•
5	3000-987	Wire Harness	•	•	•	•	•

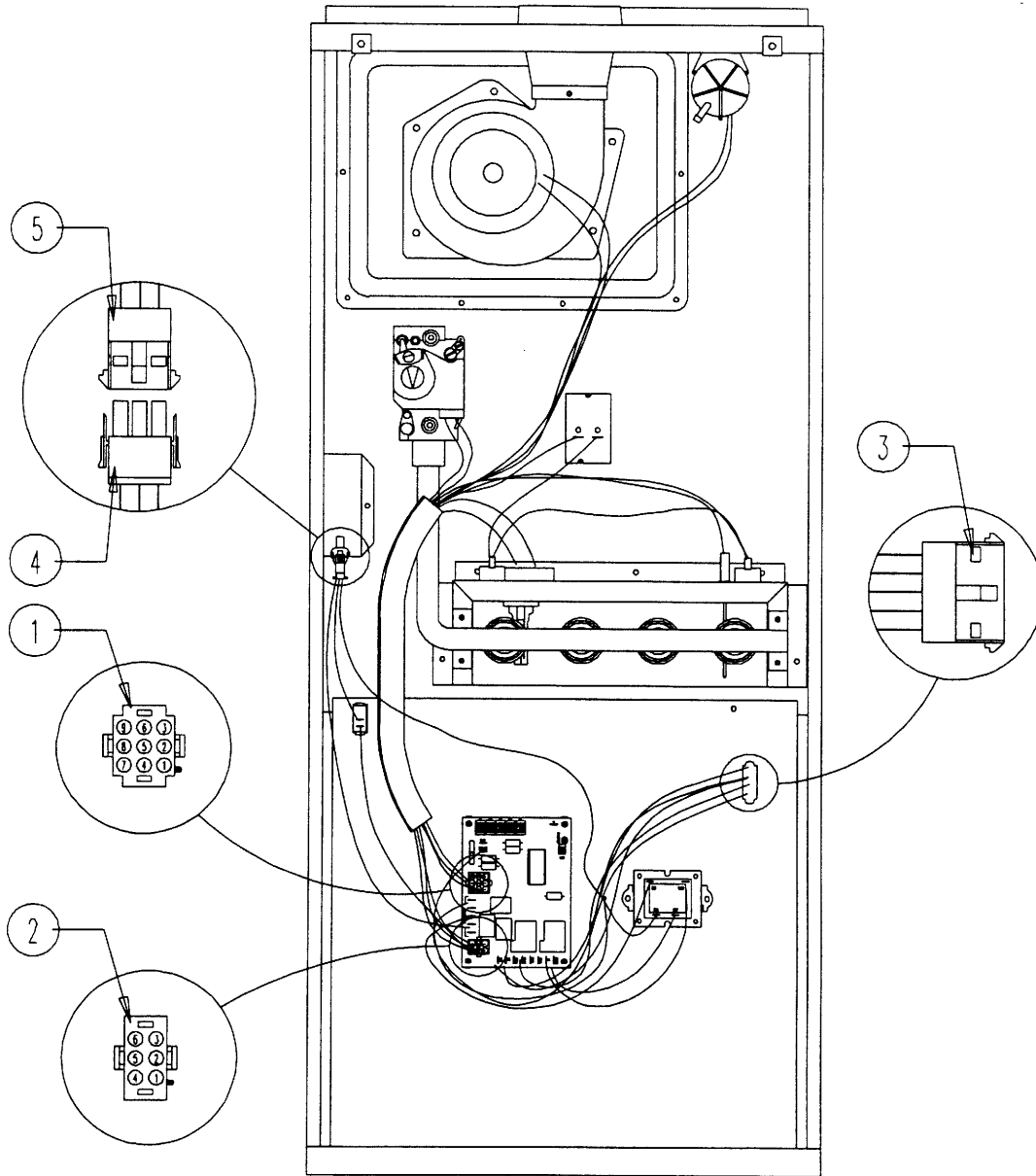

SEXP-223