

REPLACEMENT PARTS MANUAL

OIL FIRED FURNACE
MODELS: FS085D48A, FS100D48A, FS125B48A,
FS150B48A, FS200B48A

Manual 2110-911

Revision --

Date 01-10-92

Supersedes

* GENERAL NOTES *

*Revised and/or additional pages may be issued from time to time.
*A complete and current manual consists of pages dated as shown in the following index.

** INDEX **

<u>Page Description</u>	<u>Page</u>	<u>Date</u>	<u>Supersedes</u>
Functional and Cabinet Components--Exploded View	1	01-10-92	
" " " --Exploded View	2	01-10-92	
Direct Drive Blower Assembly--Exploded View	3	01-10-92	
Belt Drive Blower Assembly--Exploded View	4	01-10-92	
Functional and Cabinet Components--Usage List	5	01-10-92	
" " " --Usage List	6	01-10-92	
Blower Assembly--Usage List	7	01-10-92	
Beckett Burner Replacement Parts--Exploded View	8	01-10-92	
" " " " --Usage List	9	01-10-92	
Ducane Burner Replacement Parts--Exploded View	10	01-10-92	
" " " " --Usage List	11	01-10-92	

*** IMPORTANT ***

Contact the installing and/or local Bard distributor for all parts requirements. Make sure you have the complete model and serial number available from the unit rating plate.

BARD MANUFACTURING COMPANY

BRYAN, OHIO 43506

DUCANE HEATING CORP. NEUTER OIL FIRED HORIZONTAL HEATING UNITS.

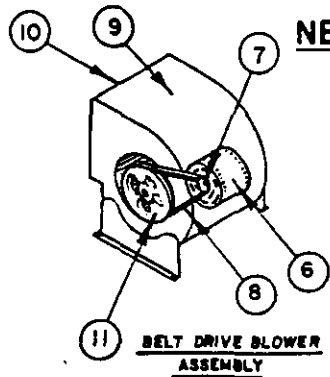

EXTERNAL FILTER RACK ARRANGEMENT
100,000; 125,000 & 150,000 ONLY

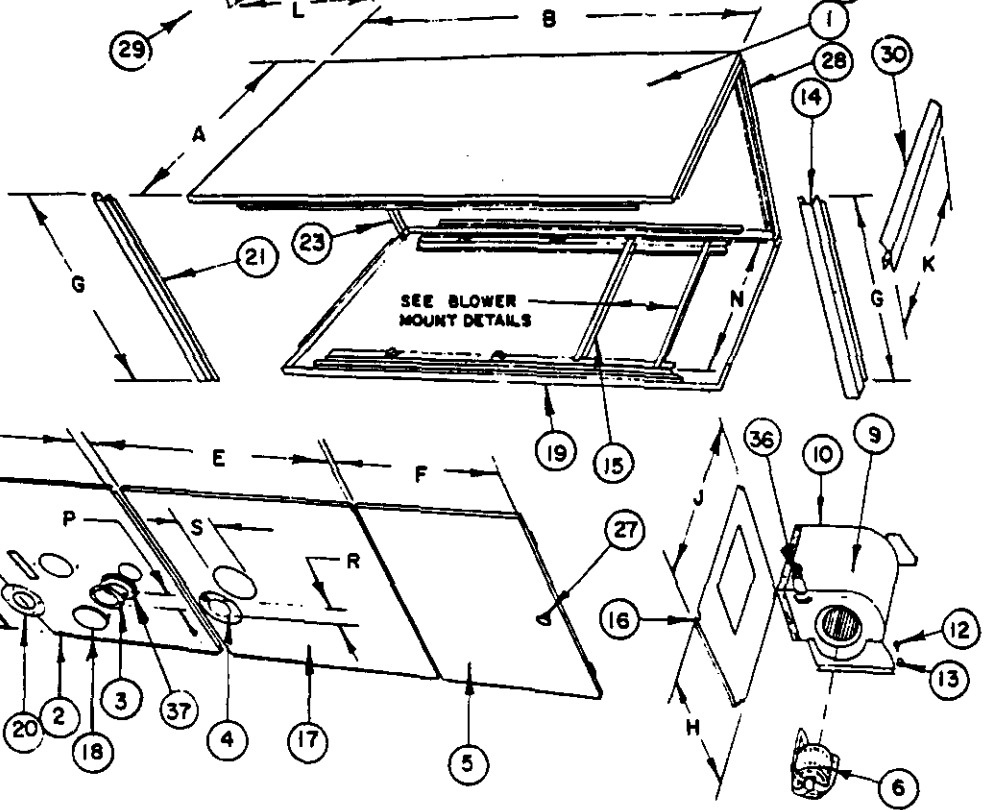
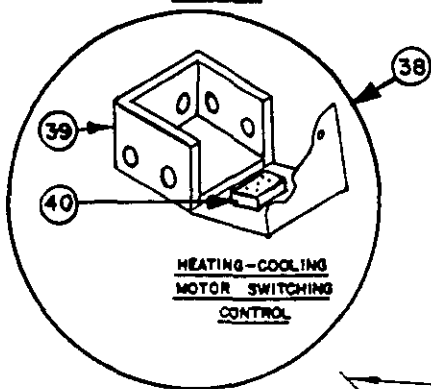
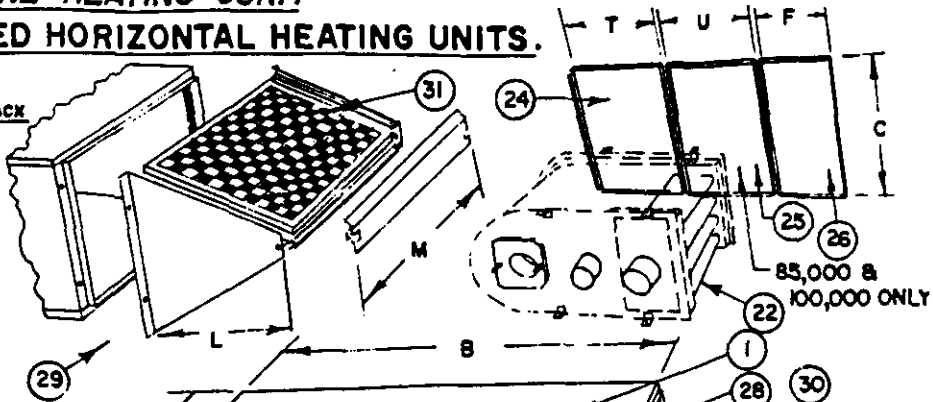

BLOWER MOUNT IDENTIFICATION

85,000 & 100,000 FOR 10x10 BLOWER AND 200,000.
SEE "N" DIMENSION FOR LENGTH.

MODEL	X
200,000 FRONT	3 ¹ / ₈
200,000 REAR	1 ¹ / ₂
85,000 & 100,000	1 ¹ / ₄

DIMENSIONS FOR IDENTIFICATION

BONNET CAPACITY	A	B	C	D	E	F	G	H	J	K	L	M	N	P	R	S	T	U
85,000	21	68	19 ¹ / ₂	25 ¹ / ₂	21 ³ / ₈	18 ¹ / ₁₆	21 ¹⁵ / ₁₆	21 ⁷ / ₈	20 ¹⁵ / ₁₆				18 ¹ / ₂	4	7	7 ¹ / ₂	25 ¹ / ₂	21 ³ / ₈
100,000	23	72	19 ¹ / ₂	25 ¹ / ₂	24 ¹ / ₂	18 ¹⁵ / ₁₆	21 ¹⁵ / ₁₆	21 ⁷ / ₈	22 ¹⁵ / ₁₆		18 ¹ / ₈	19 ¹⁵ / ₁₆	20 ¹ / ₂	4	7	7 ¹ / ₂	25 ¹ / ₂	24 ¹ / ₂
125,000	25	75	19 ¹ / ₂	27 ¹ / ₂	21 ¹ / ₄	23 ³ / ₁₆	21 ¹⁵ / ₁₆	21 ⁷ / ₈	24 ¹⁵ / ₁₆		18 ¹ / ₈	19 ¹⁵ / ₁₆		4	7	7 ¹ / ₂	48 ³ / ₄	
150,000	27	78	19 ¹ / ₂	27 ¹ / ₂	22 ¹ / ₂	24 ¹⁵ / ₁₆	21 ¹⁵ / ₁₆	21 ⁷ / ₈	26 ¹⁵ / ₁₆		18 ¹ / ₈	19 ¹⁵ / ₁₆		4	7	7 ¹ / ₂	50	
200,000	29	80	27 ¹ / ₂	33 ⁹ / ₁₆	22 ⁵ / ₈	20 ³ / ₄	29 ¹⁵ / ₁₆	29 ⁷ / ₈	28 ¹⁵ / ₁₆	28 ¹ / ₂			26	4	8	8 ¹ / ₂	56 ³ / ₁₆	

Date: 01/10/92
Supersedes:

2110-911
Page: 1

**85 & 100,000
B.T.U. UNITS
(ALUMINA SILICA CHAMBER)**

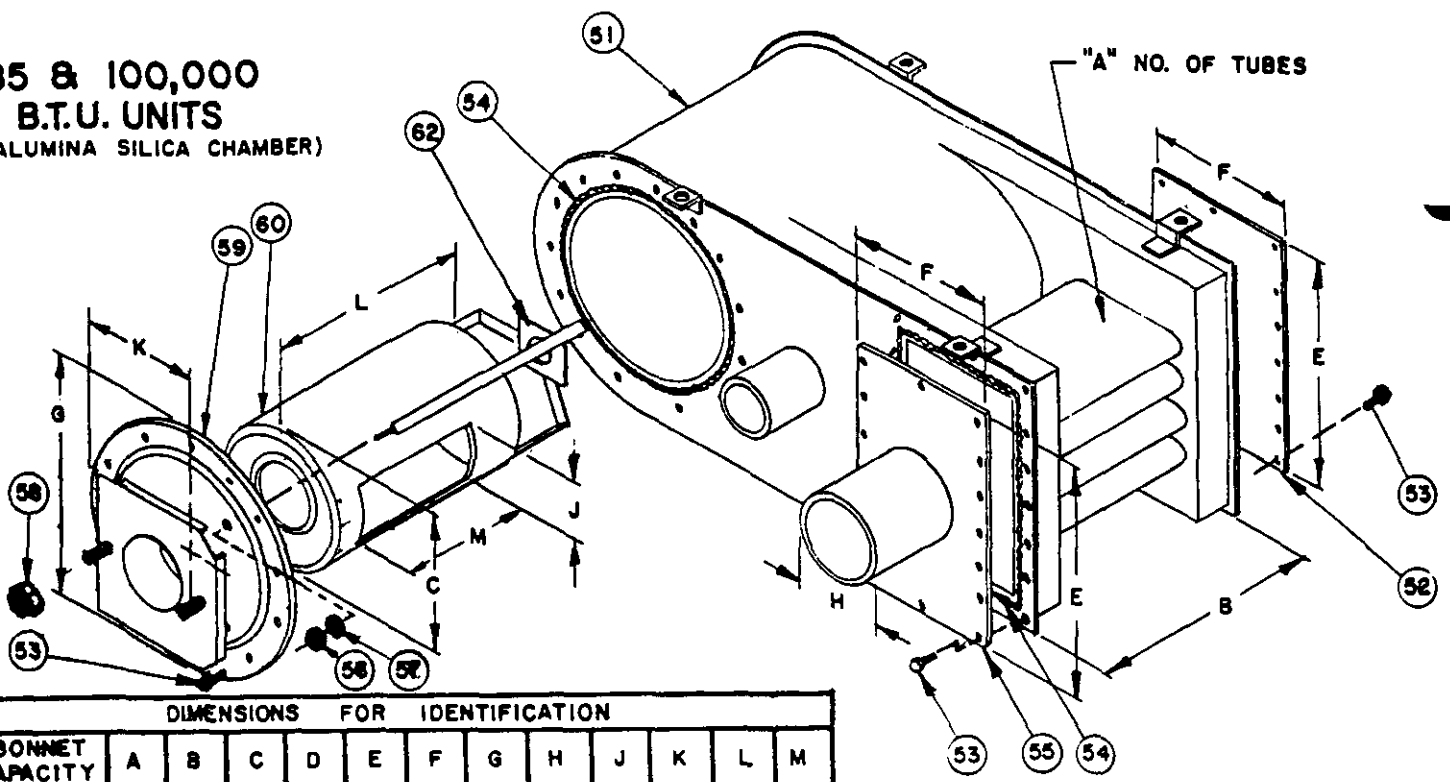

DIMENSIONS FOR IDENTIFICATION												
BONNET CAPACITY	A	B	C	D	E	F	G	H	J	K	L	M
85,000	4	16	9 $\frac{3}{4}$		16 $\frac{1}{2}$	13	15 $\frac{1}{2}$	7	6	7 $\frac{3}{4}$	15 $\frac{3}{4}$	7 $\frac{1}{2}$
100,000	4	18	11 $\frac{1}{4}$		16 $\frac{1}{2}$	13	15 $\frac{1}{2}$	7	6	7 $\frac{3}{4}$	17 $\frac{3}{4}$	9 $\frac{1}{2}$
125,000	5	20	11 $\frac{1}{4}$		18 $\frac{5}{8}$	12 $\frac{3}{8}$	16 $\frac{1}{2}$	7	6	8 $\frac{1}{4}$	19 $\frac{3}{4}$	11 $\frac{1}{2}$
150,000	6	22	12 $\frac{1}{4}$		18 $\frac{5}{8}$	12 $\frac{3}{8}$	16 $\frac{1}{2}$	7	6	8 $\frac{1}{4}$	21 $\frac{3}{4}$	12 $\frac{1}{2}$
200,000	8	23	14	4	26	12 $\frac{3}{8}$	21 $\frac{1}{2}$	8	8 $\frac{1}{2}$	11 $\frac{3}{4}$		

**HEAT EXCHANGERS FOR
NEUTER OIL FIRED (REVERSIBLE FLOW)
HORIZONTAL HEATING UNITS
BONNET CAPACITY (1,000 B.T.U./HR.)**

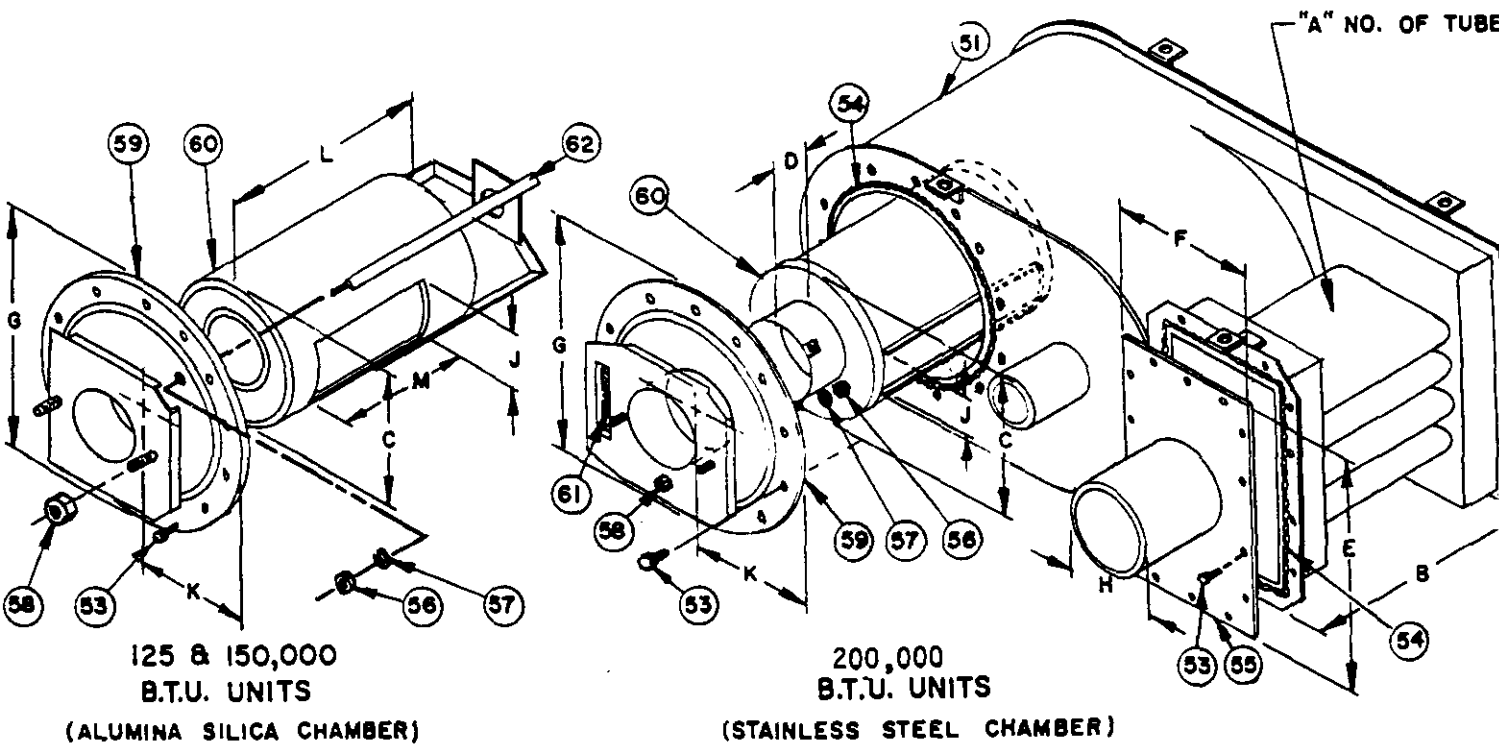

**125 & 150,000
B.T.U. UNITS
(ALUMINA SILICA CHAMBER)**

**200,000
B.T.U. UNITS
(STAINLESS STEEL CHAMBER)**

**HEAT EXCHANGERS FOR NEUTER OIL FIRED HORIZONTAL HEATING UNITS
BONNET CAPACITY (1,000 B.T.U./HR.) 125, 150, 200**

Date: 01/10/92
Supersedes:

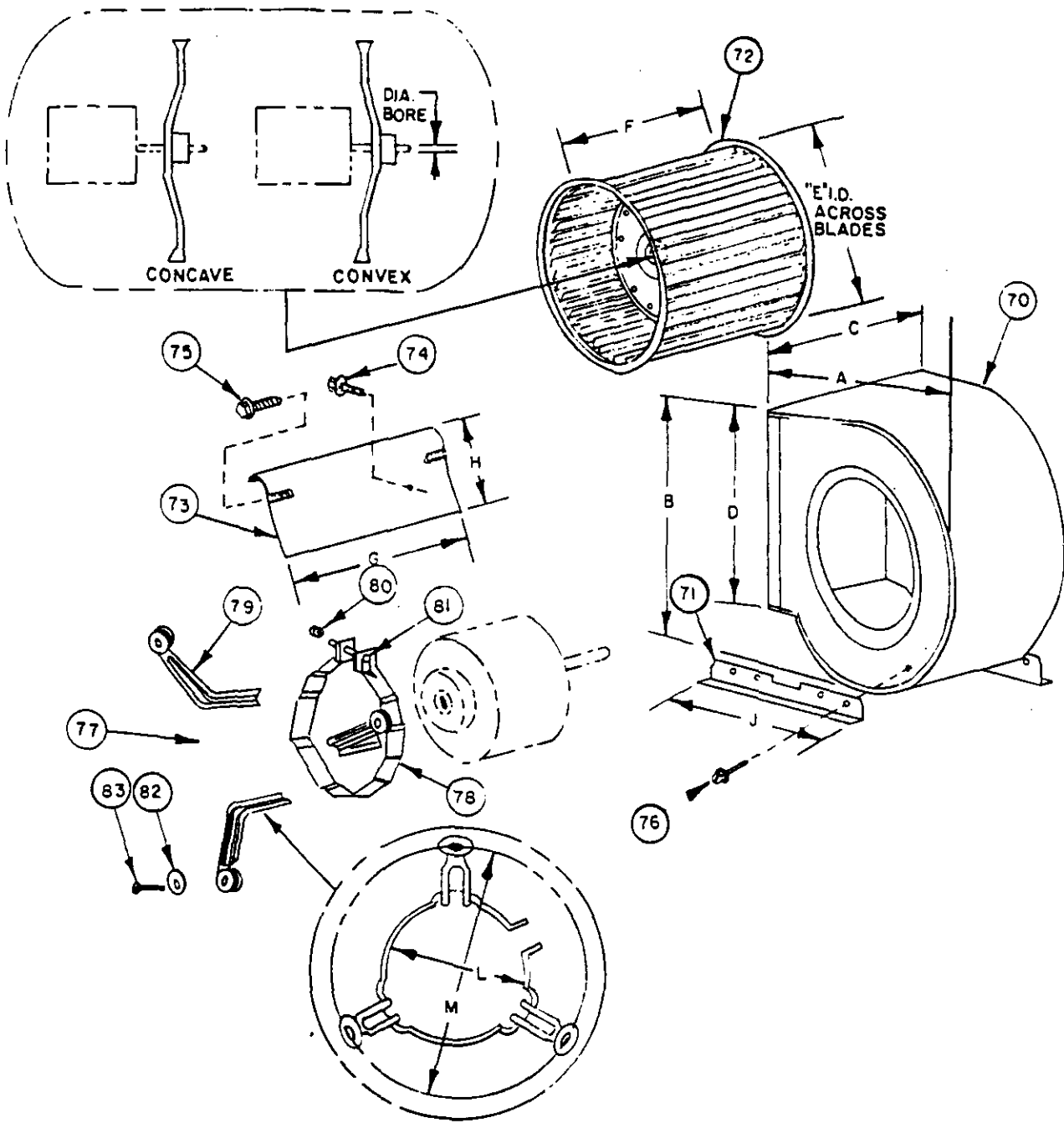

Model	DIMENSIONS FOR IDENTIFICATION												
	BLOWER SIZE	A	B	C	D	E	F	G	H	J	K	L	M
FS085		9	3	1	3	7	5	25	1	3	1	5	5
FS100	10 X 10	16 16	17 8	13 8	11 8	8 8	10 8	12 32	5 8	14 8	2 5 8	12 16	

Date: 01/10/92
Supersedes:

DIRECT DRIVE BLOWER

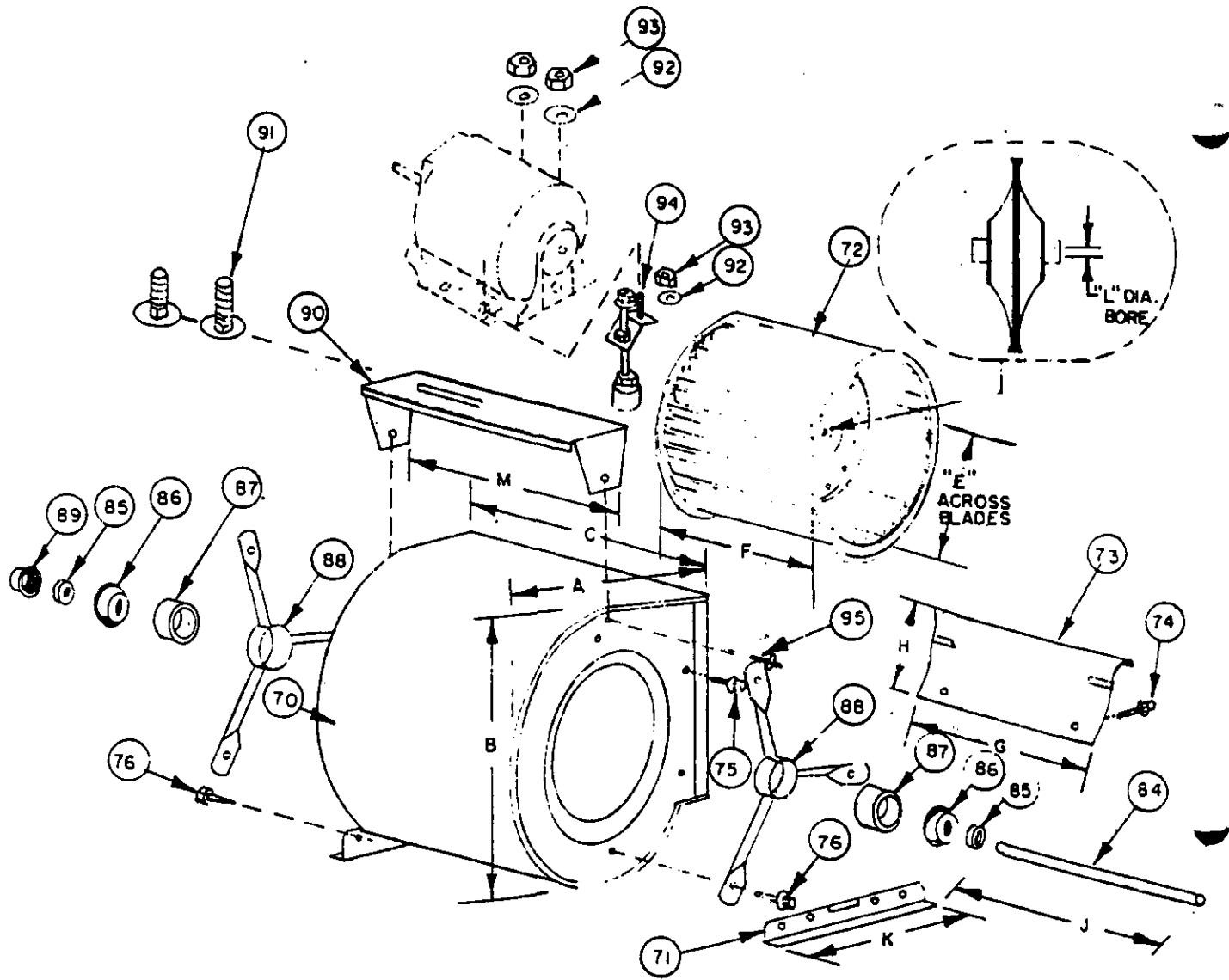

Model	DIMENSIONS FOR IDENTIFICATION												
	BLOWER SIZE	A	B	C	D	E	F	G	H	J	K	L	M
FS125	12 X 9	3 19 8	3 20 8	1 12 4	7 13 16	5 10 16	1 9 2	29 11 32	13 5 16	5 17 8	1 17 8	3 4	1 12 4
FS150	12 X 12	3 19 8	3 20 8	5 15 8	7 13 16	5 10 16	5 12 8	9 15 32	13 5 16	1 20 8	1 17 8	3 4	5 15 8
FS200													

Date: 01/10/92
Supersedes:

2110-911
Page: 4

BELT DRIVE BLOWER

FUNCTIONAL AND CABINET COMPONENTS

Dwg. No.	Part No.	Description	F S O 8 5 D 4 8 A	F S 1 0 5 D 4 8 A	F S 1 2 5 B 4 8 A	F S 1 5 0 B 4 8 A	F S 2 0 0 B 4 8 A
1	9048-001	Top Panel	X				
1	9048-002	Top Panel		X			
1	9048-003	Top Panel			X		
1	9048-004	Top Panel				X	
1	9048-005	Top Panel					X
2	9048-006	Front Left Panel	X	X			
2	9048-007	Front Left Panel			X	X	
2	9048-008	Front Left Panel					X
5	9048-009	Front Blower Door	X				
5	9048-010	Front Blower Door		X			
5	9048-011	Front Blower Door			X		
5	9048-012	Front Blower Door				X	
5	9048-013	Front Blower Door					X
6	9048-014	Motor--Direct Drive 1/3 HP	X	X			
6	8105-001	Motor--Belt Drive 1/3 HP				X	
6	8106-001	Motor--Belt Drive 1/2 HP			X		X
7	5501-001	Cast Iron Motor Pulley--1/2" Bore (For 1/3 - 1/2 HP Belt)			X	X	X
9	9048-015	Blower Assembly W/1/3 HP Belt Drive Motor (With belt and pulleys)				X	
9	9048-016	Blower Assembly W/1/2 HP Belt Drive Motor (With belt and pulleys)			X		
9	9048-017	Blower Assembly W/1/2 HP Belt Drive Motor (With belt and pulleys)					X
9	9048-018	Blower Assembly W/1/3 HP Direct Drive Motor (With Capacitor)	X	X			
10	9048-019	Blower With Legs and Motor Bracket 10x10	X	X			
10	9048-020	Belt Drive Blower With Legs and Motor Mount 12x9			X		
10	9048-021	Belt Drive Blower With Legs and Motor Mount 12x12				X	X
11	5501-012	Fan Pulley 6 x 3/4				X	
11	5501-013	Fan Pulley 7 x 3/4			X		X
14	9048-022	Inlet Corner Post Front	X	X	X	X	
14	9048-023	Inlet Corner Post Front					X
15	9048-024	Blower Mount For 10x10 Blower (Front & Rear, Same)	X				
15	9048-025	Blower Mount For 10x10 Blower (Front & Rear, Same)		X			
15	9048-026	Front Blower Mount					X
15	9048-027	Rear Blower Mount					X
17	9048-028	Front Center Panel	X				
17	9048-029	Front Center Panel		X			
17	9048-030	Front Center Panel			X		
17	9048-031	Front Center Panel				X	
17	9048-032	Front Center Panel					X
19	9048-033	Bottom Panel	X				
19	9048-034	Bottom Panel		X			
19	9048-035	Bottom Panel			X		
19	9048-036	Bottom Panel				X	
19	9048-037	Bottom Panel					X

Date: 01/10/92
Supersedes:

FUNCTIONAL AND CABINET COMPONENTS

Dwg. No.	Part No.	Description	F S 0 8 5 D 4 8 A	F S 1 0 0 D 4 8 A	F S 1 2 5 B 4 8 A	F S 1 5 0 B 4 8 A	F S 2 0 0 B 4 8 A
20	9048-038	Burner Mounting Gasket	X	X	X	X	X
21	9048-039	Outlet Corner Post Front	X	X	X	X	
21	9048-040	Outlet Corner Post Front					X
22	9048-041	Heat Exchanger (Complete With Combustion Chamber & Cover Plates)	X				
22	9048-042	Heat Exchanger (Complete With Combustion Chamber & Cover Plates)		X			
22	9048-043	Heat Exchanger (Complete With Combustion Chamber & Cover Plates)			X		
22	9048-044	Heat Exchanger (Complete With Combustion Chamber & Cover Plates)				X	
22	9048-045	Heat Exchanger (Complete With Combustion Chamber & Cover Plates)					X
23	9048-046	Outlet Corner Post Back	X	X	X	X	
23	9048-047	Outlet Corner Post Back					X
24	9048-048	Back Left Panel	X	X			
24	9048-049	Back Left Panel			X		
24	9048-050	Back Left Panel				X	
24	9048-051	Back Left Panel					X
25	9048-052	Back Center Panel	X				
25	9048-053	Back Center Panel		X			
26	9048-054	Back Blower Door	X				
26	9048-055	Back Blower Door		X			
26	9048-056	Back Blower Door			X		
26	9048-057	Back Blower Door				X	
26	9048-058	Back Blower Door					X
28	9048-059	Inlet Corner Post Back	X	X	X	X	
28	9048-060	Inlet Corner Post Back					X
29	9048-061	Filter Rack Assembly		X	X	X	
30	9048-062	Rear Center Filter Angle					X
34	8402-042	Fan & Limit Control (Not Shown)	X	X	X	X	X
35	9048-063	Draft Regulator	X	X	X	X	
35	9048-064	Draft Regulator					X
40	9048-079	Relay, Motor Switching (Single Pole Double Throw)	X	X	X	X	X
52	9048-065	Rear Cover Plate	X	X			
60	9048-066	Combustion Chamber (Alumina Silica)	X				
60	9048-067	Combustion Chamber (Alumina Silica)		X			
60	9048-068	Combustion Chamber (Alumina Silica)			X		
60	9048-069	Combustion Chamber (Alumina Silica)				X	
60	9048-070	Combustion Chamber (Stainless Steel)					X

Date: 01/10/92
Supersedes:

BLOWER ASSEMBLY

Dwg. No.	Part No.	Description	F S O 8 5 D 4 8 A	F S 1 0 D 4 8 A	F S 1 2 5 B 4 8 A	F S 1 0 B 4 8 A	F S 2 0 B 4 8 A
72	9048-080	Blower Wheel 10x10 Concave 1/2" Bore Direct Drive	x	x			
72	9048-081	Blower Wheel 12x9x3/4" Bore Belt Drive			x		
72	9048-082	Blower Wheel 12x12x3/4" Bore Belt Drive				x	x
77	9048-071	Belly Band Motor Mount For 48 Frame Motor & 10" Blower (Inc. #78 - 83)	x	x			
84	9048-072	Shaft (3/4" diameter)			x		
84	9048-073	Shaft (3/4" diameter)				x	x
86	9048-074	Bearing (3/4" bore)			x	x	x
87	9048-075	Bearing Insulator			x	x	x
88	9048-076	Bearing Bracket			x	x	x

Date: 01/10/92
Supersedes:

Beckett

MODELS
FS085D48A, FS100D48A, FS125B48A, FS150B48A

Burner Replacement Parts

Oil Burners

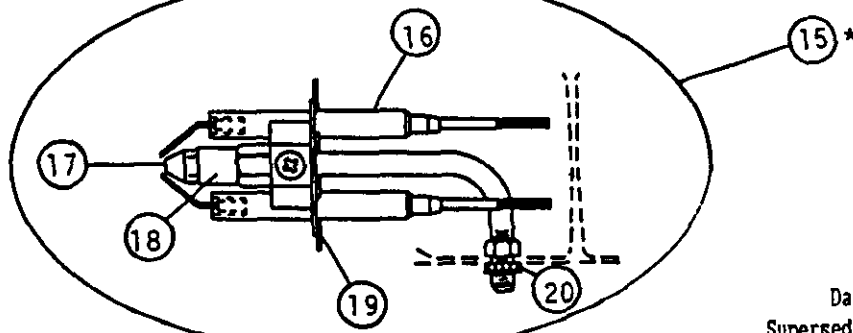
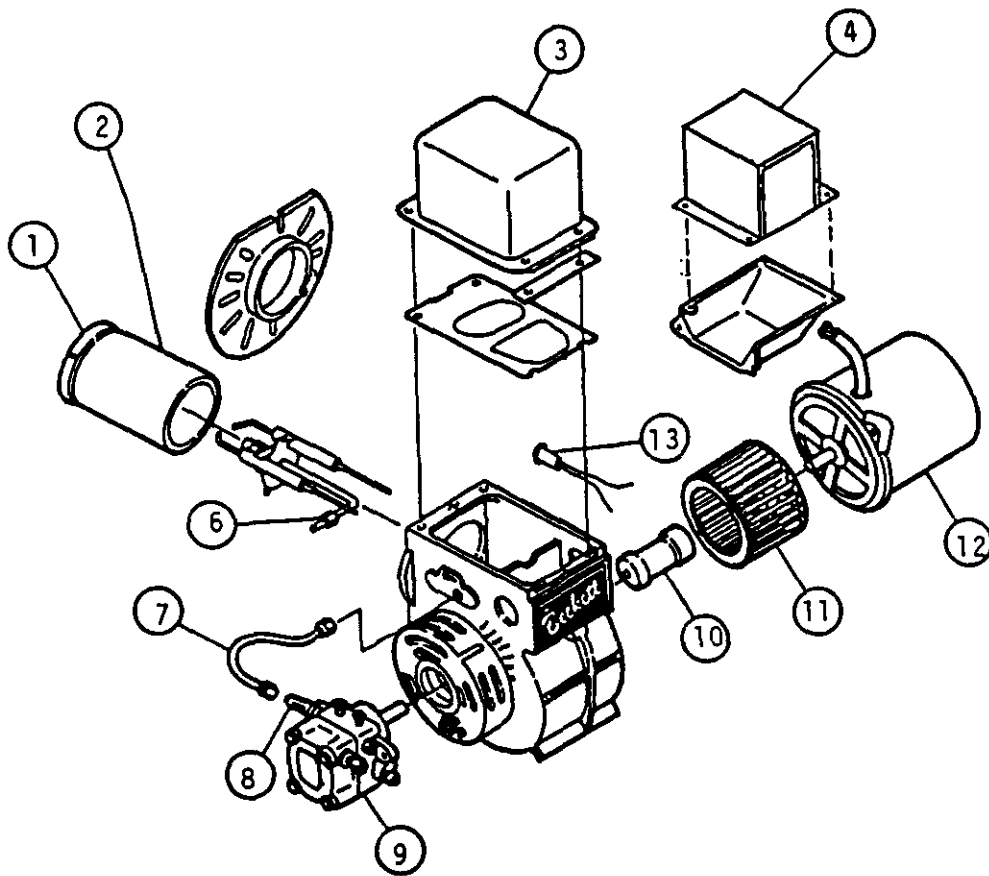

Nozzle Line Electrode Assembly

*Nozzle is not included in assembly.

Date: 01/10/92
Supersedes:

2110-911
Page: 8

BECKETT BURNER REPLACEMENT PARTS

Dwg. No.	Part No.	Beckett Part No.	Description	F S O 8 5 D 4 8 A	F S O 1 0 D 4 8 A	F S 1 2 5 B 4 8 A	F S 1 5 0 B 4 8 A
1	9022-003	F3	Head	X	X		
1	9022-042	F6	Head			X	X
NS	9022-048	31517	Ceramic Heat Shield For Burner Head	X	X	X	X
NS	9022-049	3716	Retainer For Ceramic Heat Shield	X	X	X	X
NS	9022-050	51360	F3 Head Kit W/31517 Heat Shield and 3716 Retainer	X	X		
NS	9022-051	51361	F6 Head Kit W/31517 Heat Shield and 3716 Retainer			X	X
2	9022-043	AF47YHBS	Air Tube	X	X		
2	9022-044	AF67YBBS	Air Tube			X	X
3	9022-022	5878U	Ignition Transformer W/Gasket	X	X	X	X
4	8400-003		Burner Primary Control R8184G	X	X	X	X
6	9022-007	571801	Bulkhead Fitting	X	X	X	X
7	9022-008	5636	Connector Tube	X	X	X	X
8	9022-009	2256	Pump Outlet Elbow	X	X	X	X
9	9022-010	2460U	Pump 1-Stage	X	X		
9	9022-041	2583	Pump 2-Stage			X	X
10	9022-011	2454	Coupling	X	X	X	X
11	9022-045	2999U	Blower Wheel	X	X	X	X
12	9022-013	2456U	Motor 3450 RPM	X	X	X	X
13	8400-004	7006U	Flame Detector C554A	X	X	X	X
15	9022-046	NL47YH	Nozzle Line Electrode Assembly	X	X		
15	9022-047	NL67YB	Nozzle Line Electrode Assembly			X	X
16	9022-017	5780	Electrode Insulator Assembly	X	X	X	X
17	9011-012		.75 GPH Nozzle 70 deg. Hollow	X			
17	9011-013		.90 GPH Nozzle 70 deg. Hollow		X		
17	9011-014		1.10 GPH Nozzle 70 deg. Hollow			X	
17	9011-015		1.35 GPH Nozzle 70 deg. Hollow				X
18	9022-016	213U	Nozzle Adapter	X	X	X	X
19	9022-023	3384P	Static Plate 3-3/8"	X	X		
19	9022-035	3383P	Static Plate 2-3/4"			X	X
20	9022-018	3666	Bulkhead Fitting Lockout	X	X	X	X

NS - Not Shown

Date: 01/10/92
Supersedes:

MODEL ES200B48A
WITH DUCANE DM-25 BURNER

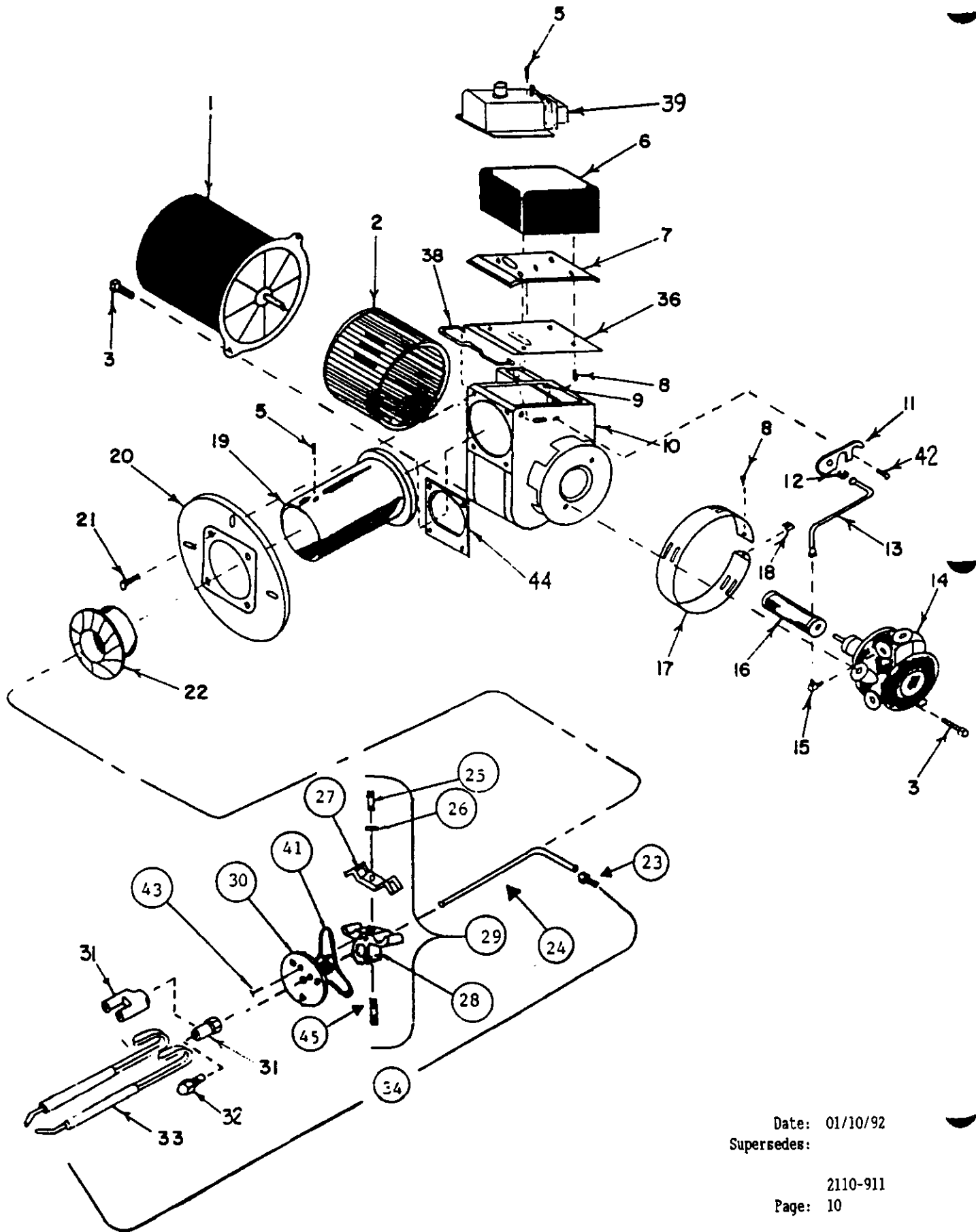

Date: 01/10/92
Supersedes:

DUCANE BURNER COMPONENTS

Dwg. No.	Part No.	Description	F S 2 0 0 D 4 8 A
1	9022-013	Motor (Fraction HP 115V, 60 Cycle, 3450 RPM)	X
2	9048-083	Blower Wheel	X
6	9048-084	Transformer (115V Primary--10,000 Volt Secondary)	X
14*	9022-041	Fuel Pump (Two Stage)	X
16	9022-011	Coupling	X
19	9048-085	Air Tube (7" Free Tube Length)	X
22	9048-086	End Cone 2-3/4" Dia. (For DM-25 Burners)	X
23	9048-097	Adapter (Oil Pipe)	X
24	9048-087	Oil Pipe (7" Free Tube Length)	X
28	9048-088	Oil Pipe/Electrode Support	X
29	9048-089	Oil Pipe/Electrode Support Assembly	X
30	9048-090	Static Disc 2-1/4" Dia. (For DM-25 Burners)	X
31	9048-095	Adapter, Nozzle (Single)	X
32	9048-096	Nozzle 1.75 GPH 80° Solid	X
33	9048-091	Electrode Assembly (Left & Right) (7" Free Tube Length)	X
34	9048-092	Electrode--Oil Pipe Assy For DM-25 (7" Free Tube Length)(Less Nozzle)	X
36	9048-093	Transformer Mounting Plate Gasket	X
39	8400-003	Primary Relay--Honeywell R8184G	X
40	8400-004	Cad Cell--Honeywell (Not Shown) C554A	X
44	9408-094	Blast Tube Gasket	X

Date: 01/10/92
Supersedes: