

# REPLACEMENT PARTS MANUAL

## OIL FIRED FURNACE

MODELS: FC085D36C

Manual 2110-913

Revision A

Date 12-15-93

Supersedes 07-5-93

\*\*\*\*\*  
\* GENERAL NOTES \*  
\*\*\*\*\*

\*Revised and/or additional pages may be issued from time to time.  
\*A complete and current manual consists of pages dated as shown in the following index.

\*\*\*\*\*  
\*\* INDEX \*\*  
\*\*\*\*\*

<u>Page Description</u>	<u>Page</u>	<u>Date</u>	<u>Supersedes</u>
Cabinet Components--Layout	1	7-15-93	
" " --Usage List	2	7-15-93	
Functional Components--Layout	3	7-15-93	
" " --Usage List	4	12-15-93	7-15-93
Burner Components--Layout	5	7-15-93	
" " --Usage List	6	7-15-93	
Burner/Combustion Chamber Mounting System--Layout	7	7-15-93	
" " " " " --Usage	8	7-15-93	

\*\*\*\*\*  
\*\*\* IMPORTANT \*\*\*  
\*\*\*\*\*

Contact the installing and/or local Bard distributor for all parts requirements. Make sure you have the complete model and serial number available from the unit rating plate.

BARD MANUFACTURING COMPANY

BRYAN, OHIO 43506

CABINET COMPONENTS

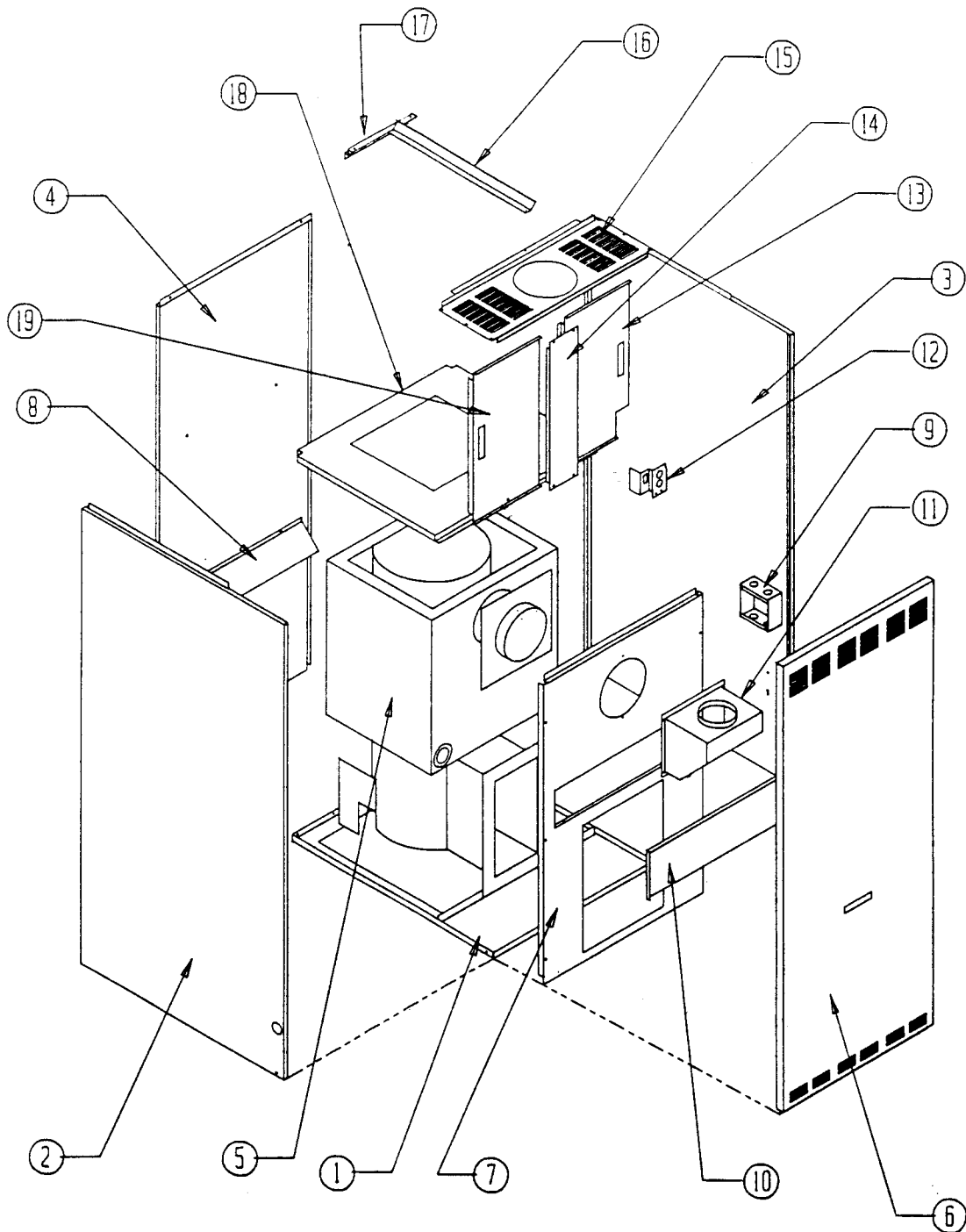

Date: 7-15-93  
Supersedes:

CABINET COMPONENTS

Dwg. No.	Part No.	Description	FC085D36C
1	127-177	Lower Base Assembly	X
2	S501-219	Left Side Assembly (Furnace serial number required)	X
3	S501-218	Right Side Assembly (Furnace serial number required)	X
4	508-084	Back Assembly	X
5	171-210	Heat Exchanger Assembly	X
6	S152-193	Burner Door Assembly	X
7	S520-226	Partition Assembly	X
8	134-111	Rear Air-Deflector	X
9	116-157	Junction Box	X
10	542-037	Clean Out Cover Assembly	X
11	913-0069	Flue Box Assembly	X
12	112-172	Door Switch Bracket	X
13	S152-230	Right Filter Door	X
14	152-196	Center Filter Access	X
15	107-127	Top Fill	X
16	130-023	Filter Support	X
17	130-062	Rear Filter Support	X
18	126-178	Blower Base	X
19	152-195	Left Filter Door	X

Date: 7-15-93  
Supersedes:

FUNCTIONAL COMPONENTS

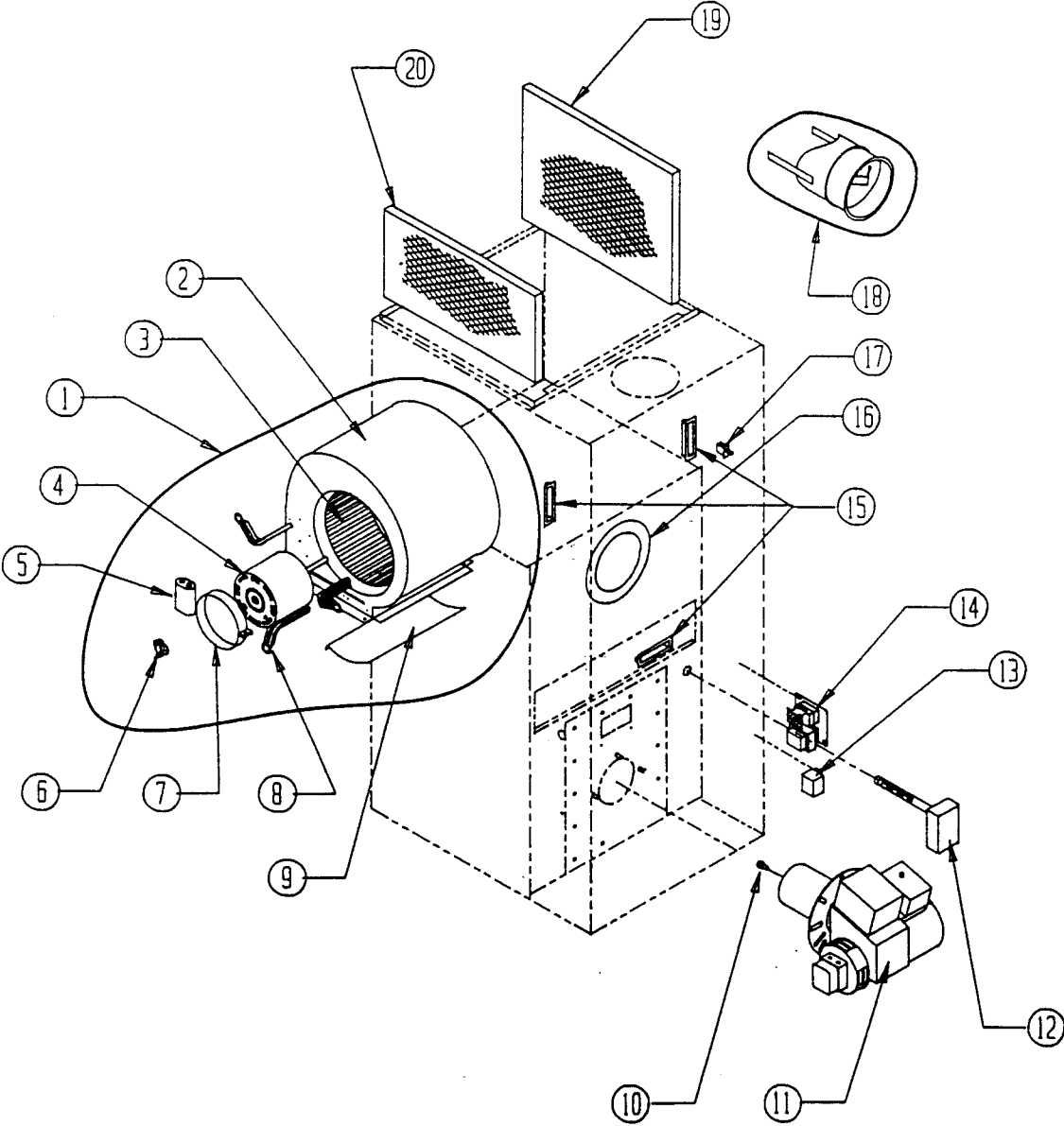

Date: 7-15-93  
Supersedes:

FUNCTIONAL COMPONENTS

Dwg. No.	Part No.	Description	FC085D36C
1	900-196	Blower Assenbly	x
2	151-095	Blower Housing Spotweld Assembly	x
3	5152-014	Blower Wheel 10-9	x
4	8105-040	Motor 1/3 HP 115V CCW 1050 RPM	x
5	8552-002	Capacitor 5/370	x
6	8402-020	Limit Switch 135-120	x
7	8200-033	Motor Mount Band	x
8	8200-034	Motor Mount Arm	3
9	144-128	Diffuser	x
10	9011-001	Nozzle .75 GPH 80 Degree Hollow	x
11	901-0106	AF Burner Assenbly (Includes nozzle part No. 9011-001)	x
12	8620-082	Fan and Limit Assenbly	x
13	8201-066	Heating Relay	x
14	8201-006	Fan Center (Two Speed Relay)	x
15	1171-025	Flush Mount Door Pull	x
16	1921-006	Fiberfrax Gasket	x
17	8406-047	Panel Mount Door Switch	x
18	8601-031	RC6 Barometric Damper	x
19	7003-022	15x20x1 Permanent Filter	x
20	7003-021	10x20x1 Permanent Filter	x
	4047-113	Wire Diagram	x

Date: 12-15-93  
Supersedes: 7-15-93

## Burner Replacement Parts

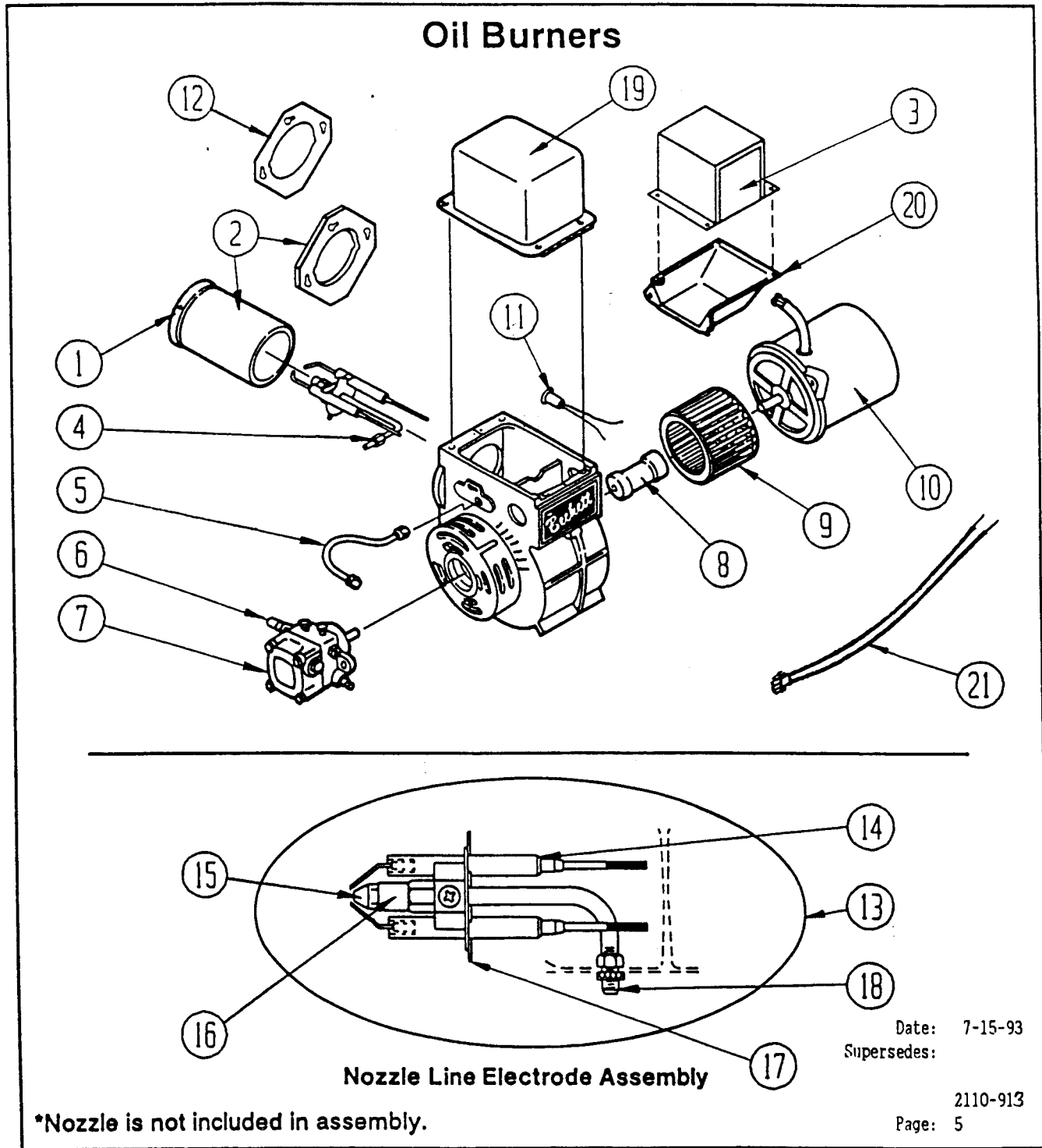

BURNER COMPONENTS

Dwg. No.	Bard Part No.	Supplier Part No.	Description	FC085D36C
1	9022-003	F3	Head	X
2	9022-004	51236007BK	Air Tube and Flange Assy. 7-5/8" Insertion	X
3	9022-056	7022U	Primary Control	X
4	9022-007	571801	Bulkhead Fitting	X
5	9022-008	5636	Connector Tube	X
6	9022-009	2256	Pump Outlet Elbow	X
7	9022-010	2460U	Pump, Single Stage	X
8	9022-011	2454	Coupling	X
9	9022-012	2459U	Blower	X
10	9022-013	2456U	Motor 1/7 HP 3450 RPM	X
11	9022-054	7006U	Cad Cell	X
12	9022-021	3811	Mounting Flange Gasket	X
13	9022-014	NL90YH	Nozzle Line Electrode Assembly	X
14	9022-017	5780	Electrode Insulator Assembly	X
15	9011-001		Nozzle .75 GPH 80 degree A	X
16	9022-016	213U	Nozzle Adapter, Single	X
17	9022-023	3384P	Static Plate 3-3/8"	X
18	9022-018	3666	Bulkhead Fitting Locknut	X
19	9022-057	2442U	Iron Core Transformer	X
20	9022-058	5770	Electrical Box Kit	X
21	9022-055	31838	Power Cord	X

Date: 7-15-93  
Supersedes:

BURNER/COMBUSTION CHAMBER MOUNTING SYSTEM

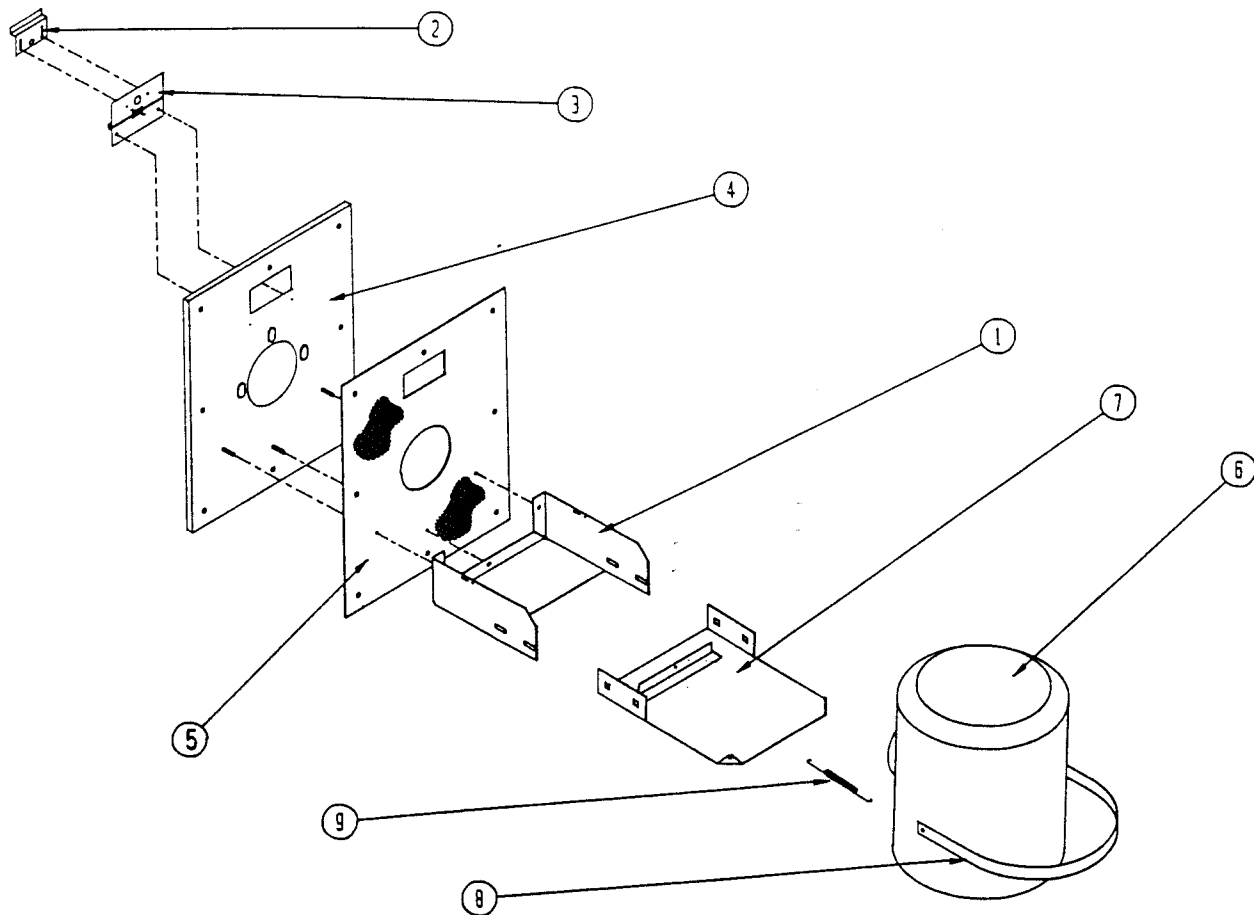

Date: 7-15-93  
Supersedes:



BURNER/COMBUSTION CHAMBER MOUNTING SYSTEM

Dwg. No.	Bard Part No.	Description	FC085D36C
1	S112-159	Combustion Chamber Bracket	x
2	142-026	Inspection Door Cover Plate	x
3	142-027	Inspection Door Hinge	x
4	161-033	Front Plate Assembly	x
5	1921-026	Front Plate Gasket	x
6	7090-005	Combustion Chamber	x
7	112-160	Bracket Extension	x
8	140-198	Combustion Chamber Support	x
9	5401-004	Stainless Steel Spring	x

Date: 7-15-93  
 Supersedes:

2110-913  
 Page: 8