

REPLACEMENT PARTS MANUAL

OIL FIRED FURNACE

MODELS: FLF085D36C, FLF110D48C

Manual 2110-914

Revision A

Date 12-15-93

Supersedes 7-15-93

* GENERAL NOTES *

*Revised and/or additional pages may be issued from time to time.
*A complete and current manual consists of pages dated as shown in the following index.

** INDEX **

<u>Page Description</u>	<u>Page</u>	<u>Date</u>	<u>Supersedes</u>
Cabinet Components--Exploded View	1	7-15-93	
" " --Usage List	2	7-15-93	
Functional Components--Exploded View	3	7-15-93	
" " --Usage List	4	12-15-93	7-15-93
Burner Components--Layout	5	7-15-93	
" " --Usage List	6	7-15-93	
Burner/Combustion Chamber Mounting System--Layout	7	7-15-93	
" " " " " --Usage	8	7-15-93	

*** IMPORTANT ***

Contact the installing and/or local Bard distributor for all parts requirements. Make sure you have the complete model and serial number available from the unit rating plate.

BARD MANUFACTURING COMPANY

BRYAN, OHIO 43506

CABINET COMPONENTS

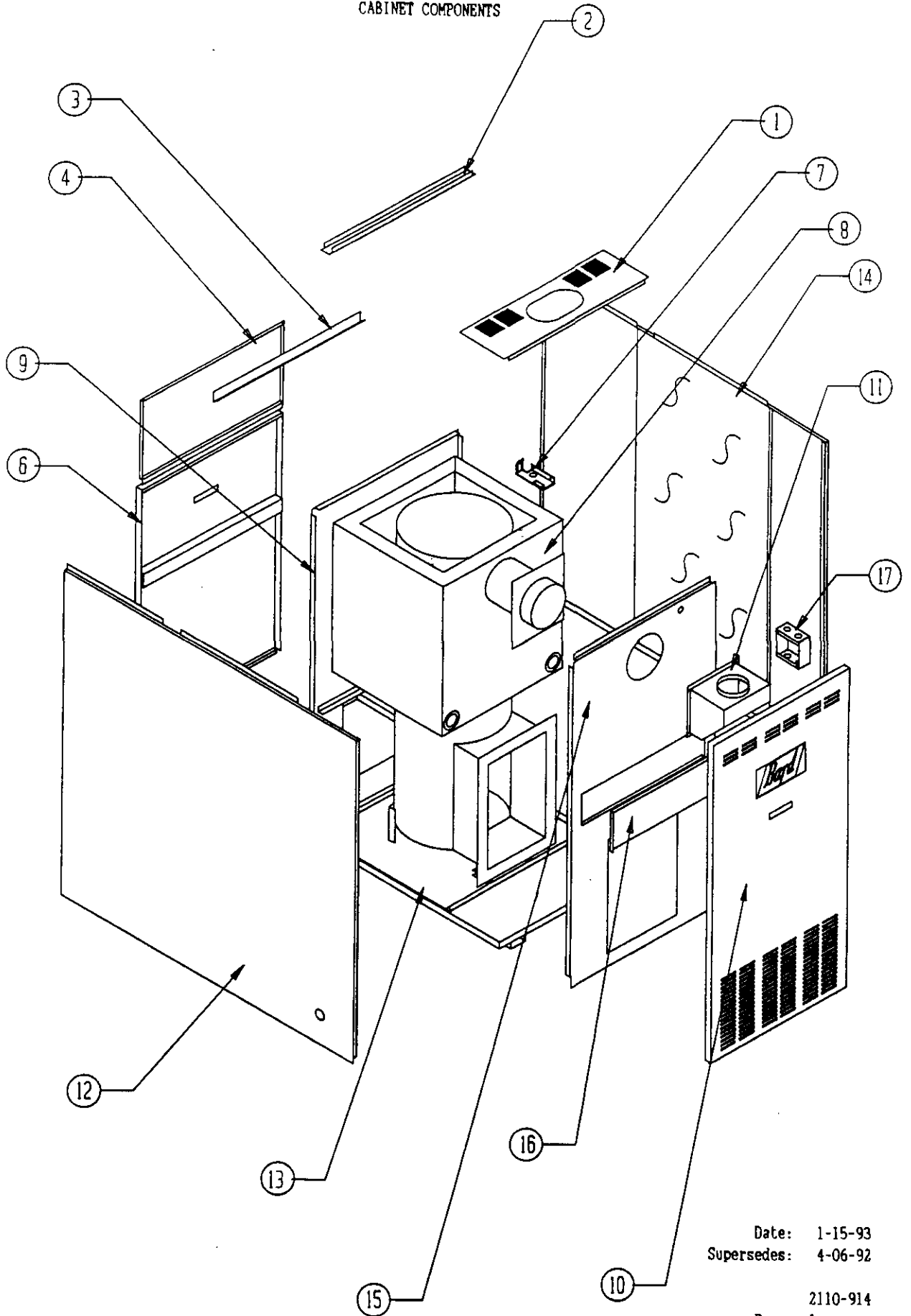

Date: 1-15-93
Supersedes: 4-06-92

CABINET COMPONENTS

Dwg. No.	Part No.	Description	FLF085D36C	FLF110D48C
1	106-139	Top Fill	X	X
2	164-536	Top Channel	X	X
3	540-189	Filter Support	X	X
4	108-080	Upper Back	X	
4	108-081	Upper Back		X
6	S552-219	Blower Door	X	X
7	116-173	Door Switch Bracket	X	X
8	S171-211	Heat Exchanger Assembly	X	
8	S171-213	Heat Exchanger Assembly		X
9	521-221	Blower Partition	X	
9	521-223	Blower Partition		X
10	S152-184	Burner Door	X	
10	S152-185	Burner Door		X
11	913-0069	Flue Box Assembly	X	X
12	S501-247	Left Side (Furnace serial number required)	X	
12	S501-249	Left Side (Furnace serial number required)		X
13	127-175	Base	X	X
14	S501-246	Right Side	X	
14	S501-248	Right Side		X
15	S520-220	Burner Partition	X	
15	S520-222	Burner Partition		X
16	542-037	Cleanout Cover Plate	X	X
17	116-157	Junction Box	X	X

Date: 7-15-93
Supersedes:

FUNCTIONAL COMPONENTS

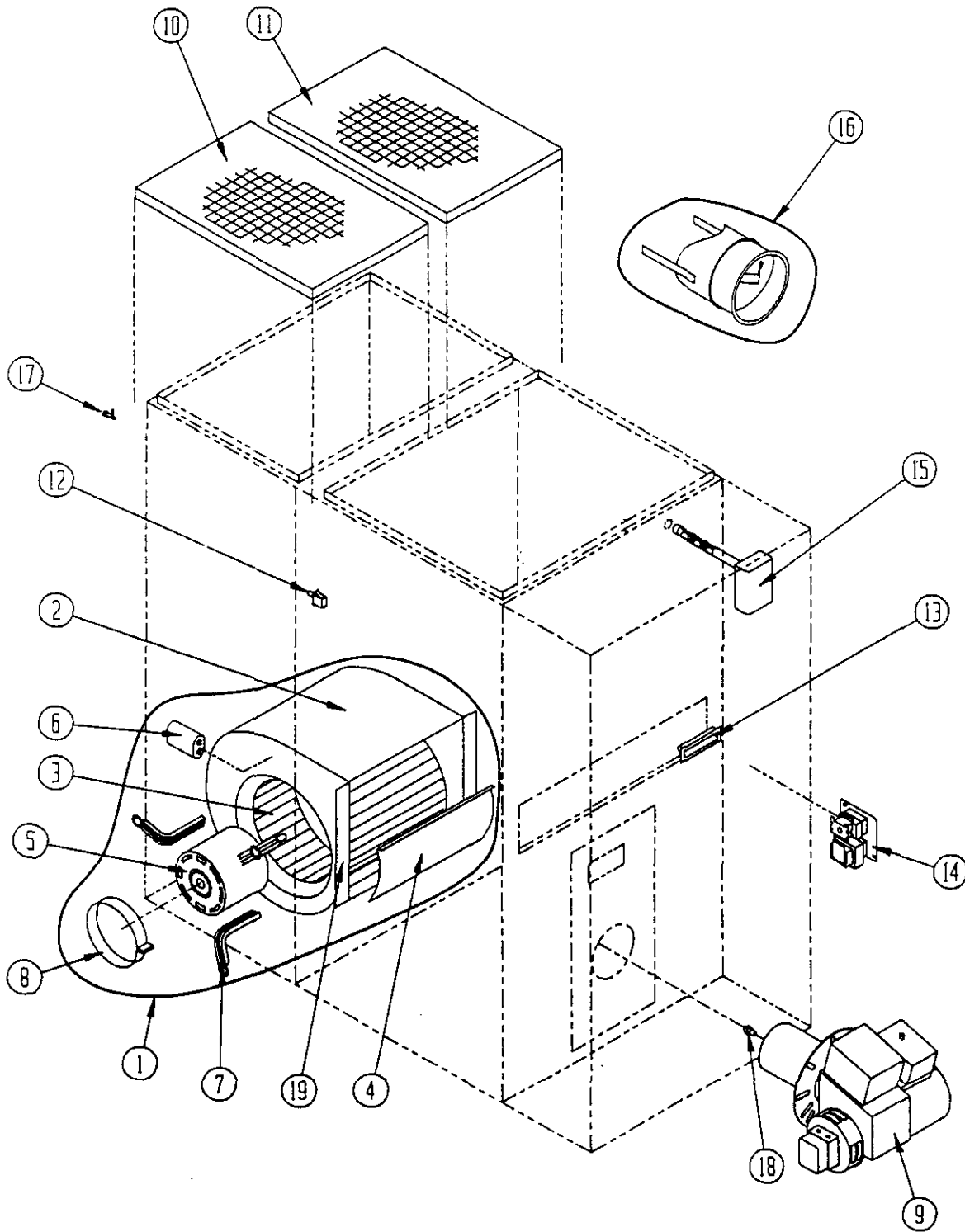

Date: 7-15-93
Supersedes:

2110-914
Page: 3

FUNCTIONAL COMPONENTS

Dwg. No.	Part No.	Description	FLF085D36C	FLF110D48C
1	900-197	Blower Assenbly	X	
1	900-198	Blower Assenbly		X
2	151-073	Blower Housing Assembly	X	
2	151-082	Blower Housing Assembly		X
3	5152-014	Blower Wheel	X	
3	5152-059	Blower Wheel		X
4	144-128	Diffuser	X	
4	144-129	Diffuser		X
5	8105-040	Motor 1/3 hp ccw	X	
5	8106-033	Motor 1/2 hp cw		X
6	8552-002	Capacitor 5/370	X	
6	8552-004	Capacitor 7.5/370		X
7	8200-034	Motor Mount Arm	3	3
8	8200-033	Motor Mount Band	X	X
9	901-0106	Burner Assembly (Includes nozzle part No. 9011-001)	X	
9	901-0107	Burner Assembly (Includes nozzle part No. 9011-003)		X
10	7003-020	Permanent Filter 11.5 x 17 x 1	X	
10	7003-021	Permanent Filter 10 x 20 x 1		X
11	7003-020	Permanent Filter 11.5 x 17 x 1	X	
11	7003-016	Permanent Filter 13 x 20 x 1		X
12	8406-047	Door Switch		X
13	1171-025	Door Pull	2	2
14	8201-006	Fan Center	X	X
15	8620-081	Fan/Limit Control	X	X
16	8601-031	Barometric Damper	X	X
17	1171-012	Slotted Cabinet Latch	X	X
18	9011-001	Nozzle .75 GPH 80 Degree	X	
18	9011-003	Nozzle 1.00 GPH 80 Degree		X
19	104-794	Blower Angles	2	2
	4047-114	Wire Diagram	X	X

Date: 12-15-93
Supersedes: 7-15-93

Burner Replacement Parts

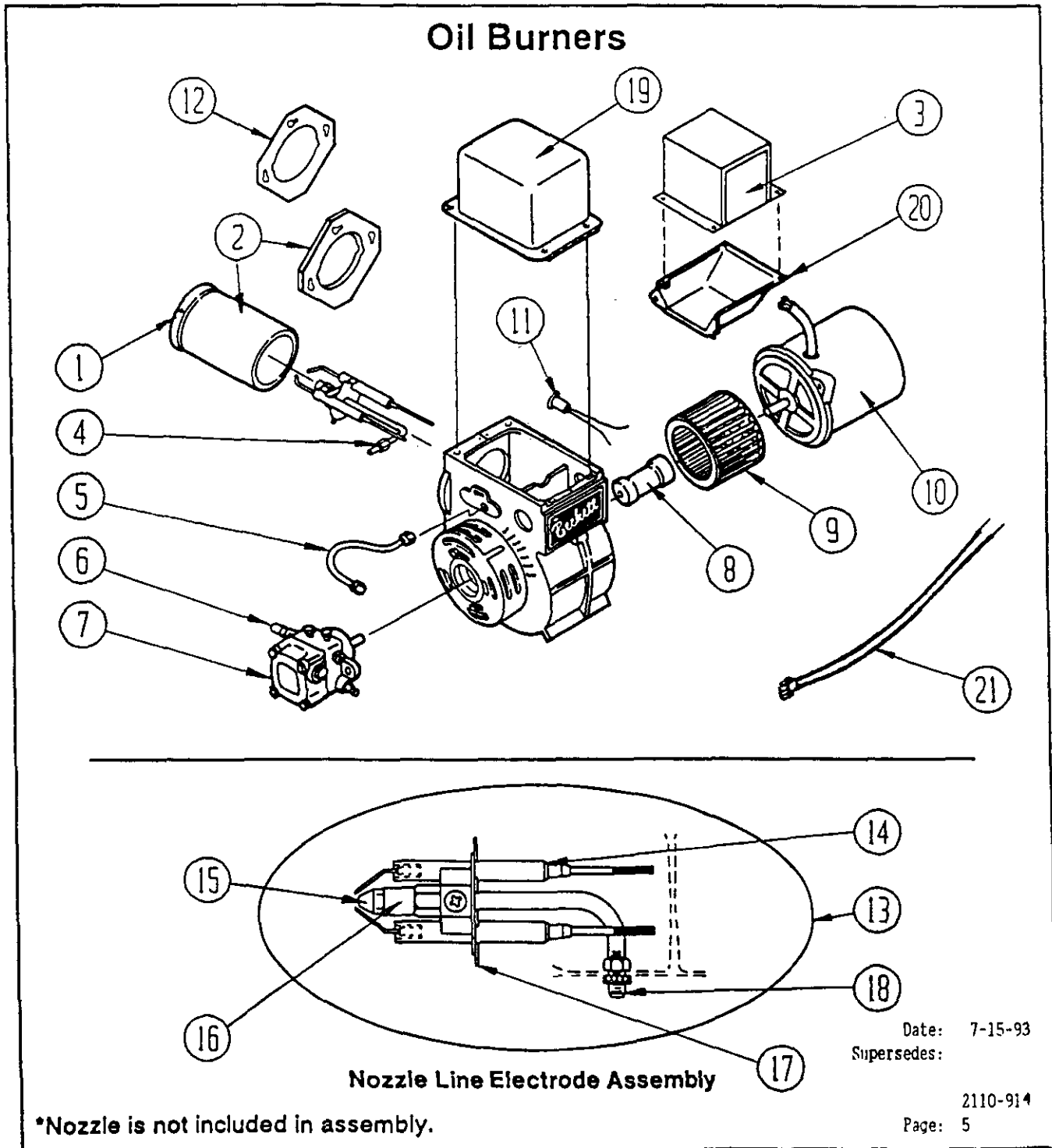

BURNER COMPONENTS

Dwg. No.	Bard Part No.	Supplier Part No.	Description	FLF085D36C	FLF110D48C
1	9022-003	F3	Head	X	X
2	9022-004	51236007BK	Air Tube and Flange Assembly 7-5/8" Insertion	X	X
3	9022-056	7022U	Primary Control	X	X
4	9022-007	571801	Bulkhead Fitting	X	X
5	9022-008	5636	Connector Tube	X	X
6	9022-009	2256	Pump Outlet Elbow	X	X
7	9022-010	2460U	Pump, Single Stage	X	X
8	9022-011	2454	Coupling	X	X
9	9022-012	2459U	Blower	X	X
10	9022-013	2456U	Motor 1/7 HP 3450 RPM	X	X
11	9022-054	7006U	Cad Cell	X	X
12	9022-021	3811	Mounting Flange Gasket	X	X
13	9022-014	NL90YH	Nozzle Line Electrode Assembly	X	X
14	9022-017	5780	Electrode Insulator Assembly	X	X
15	9011-001		Nozzle .75 GPH 80 degree A	X	
15	9011-003		Nozzle 1.00 GPH 80 degree A		X
16	9022-016	213U	Nozzle Adapter, Single	X	X
17	9022-023	3384P	Static Plate 3-3/8"	X	X
18	9022-018	3666	Bulkhead Fitting Locknut	X	X
19	9022-057	2442U	Ignition Transformer	X	X
20	9022-058	5770	Electric Box Kit	X	X
21	9022-055	31838	Power Cord	X	X

Date: 7-15-93
Supersedes:

BURNER/COMBUSTION CHAMBER MOUNTING SYSTEM

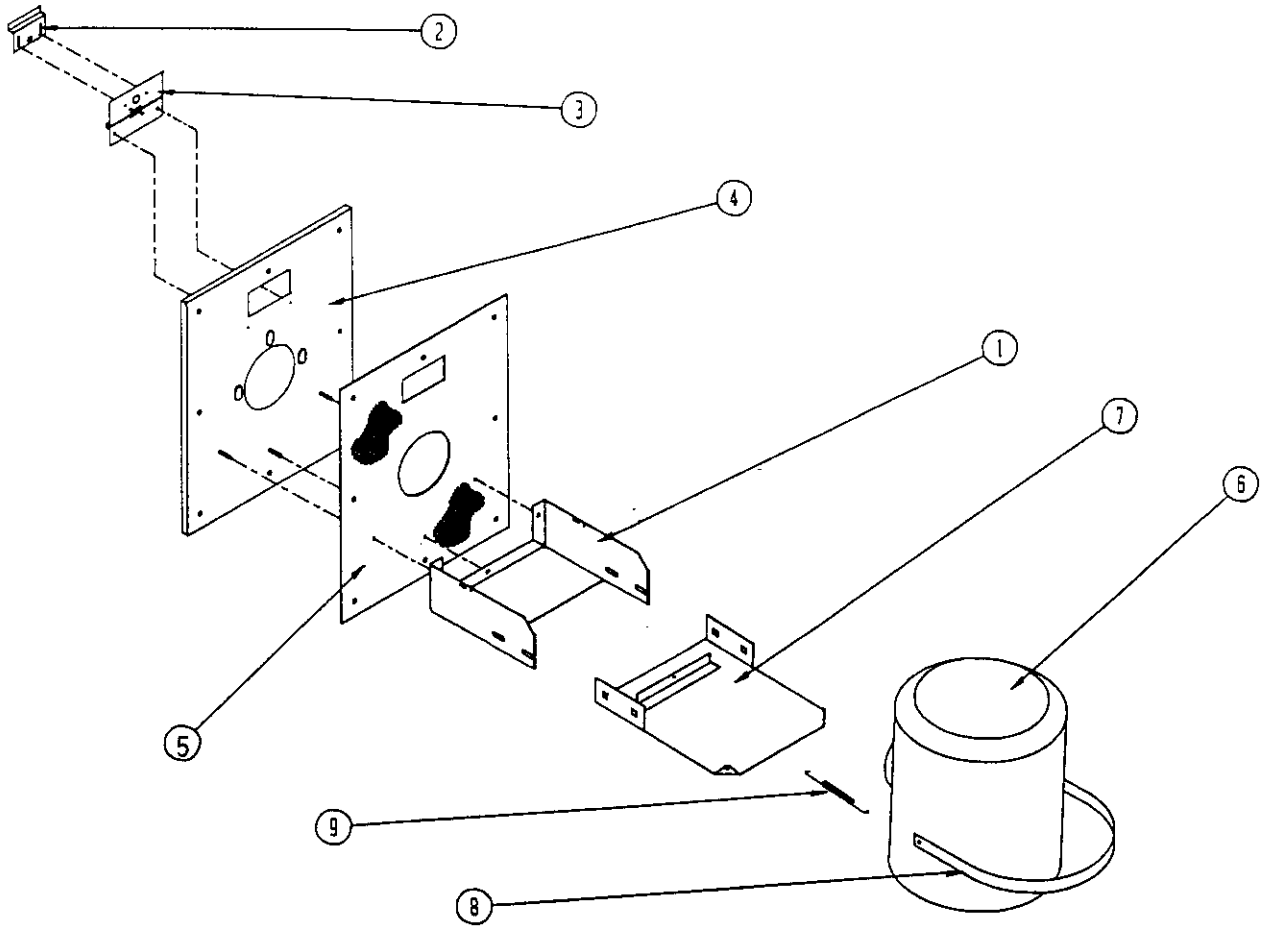

Date: 7-15-93
Supersedes:

BURNER/COMBUSTION CHAMBER MOUNTING SYSTEM

Dwg. No.	Bard Part No.	Description	FLF085D36C	FLF110D48C
1	S112-159	Combustion Chamber Bracket	X	X
2	142-026	Inspection Door Cover Plate		
3	142-027	Inspection Door Hinge	X	X
4	161-033	Front Plate Assembly	X	X
5	1921-026	Front Plate Gasket	X	X
6	7090-005	Combustion Chamber	X	X
7	112-160	Bracket Extension	X	X
8	140-198	Combustion Chamber Support	X	X
9	5401-004	Stainless Steel Spring	X	X

Date: 7-15-93
 Supersedes:

