REPLACEMENT PARTS MANUAL

OIL FIRED FURNACE

Models: **FLF085D36C**
FLF110D48C

General Notes

- Revised and/or additional pages may be issued from time to time.
- A complete and current manual consists of pages shown in the following contents section.

Important

- Contact the installing and/or local Bard distributor for all parts requirements. Make sure you have the complete model and serial number available from the unit rating plate.

Contents

Description	Page
Cabinet Components	
♦ Exploded View	1
♦ Usage List	2
Functional Components	
♦ Exploded View	3
♦ Usage List	4
Burner Components	
♦ Layout View	5
♦ Usage List	6
Burner / Combustion Chamber Mounting System	
♦ Layout View	7
♦ Usage List	8



BARD MANUFACTURING COMPANY
Bryan, Ohio 43506

Since 1914...Moving ahead, just as planned.

Manual: 2110-914D
Supersedes: Rev. C
Date: 06-10-99

CABINET COMPONENTS

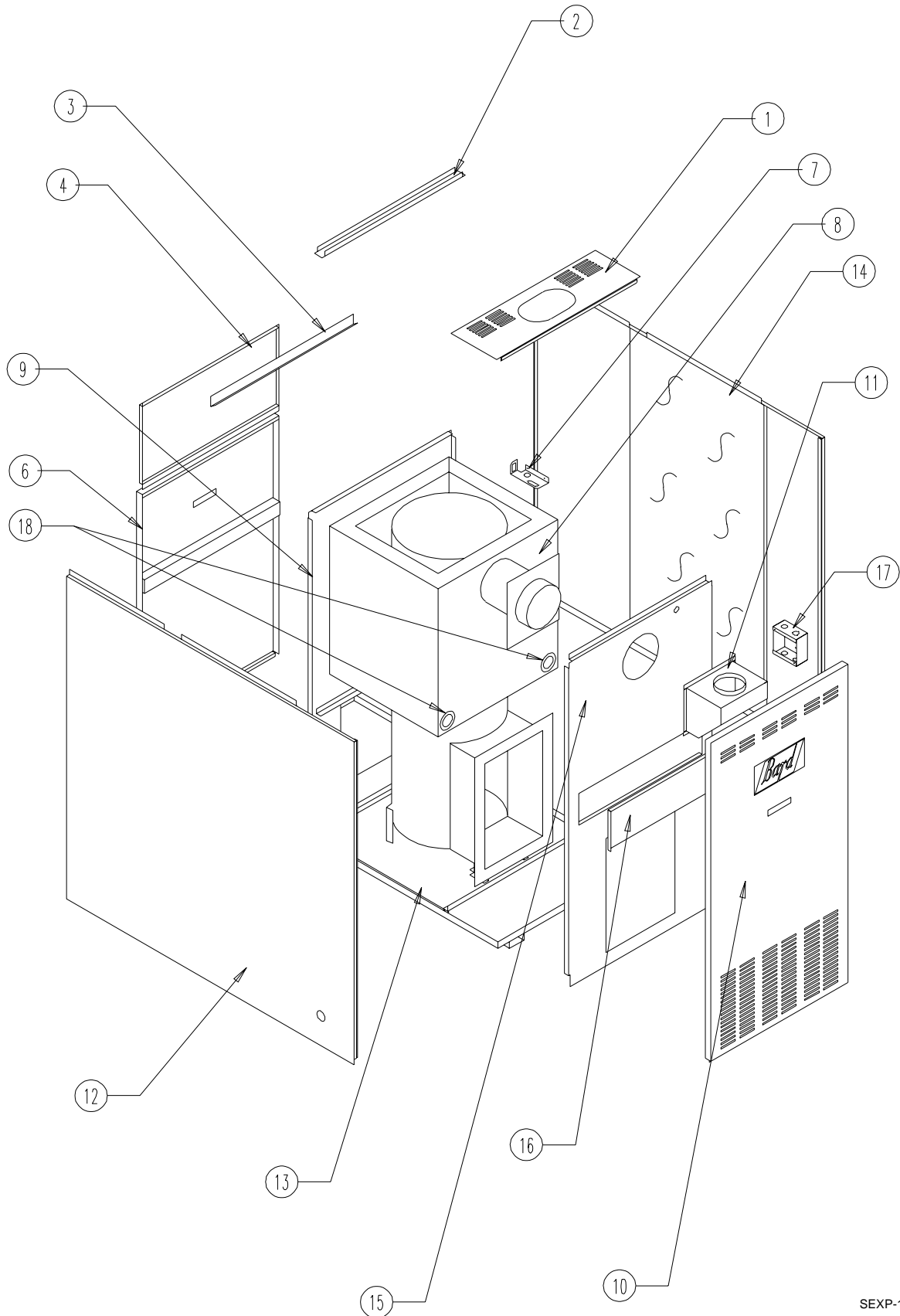

SEXP-131

CABINET COMPONENTS

Dwg. No.	Part No.	Description	FLF085D36C	FLF110D48C
1	106-139	Top Fill	X	X
2	164-536	Top Channel	X	X
3	540-189	Filter Support	X	X
4	108-080	Upper Back	X	
4	108-081	Upper Back		X
6	S552-219	Blower Door	X	X
7	116-173	Door Switch Bracket	X	X
8	S171-211	Heat Exchanger Assembly	X	
8	S171-213	Heat Exchanger Assembly		X
9	521-221	Blower Partition	X	
9	521-223	Blower Partition		X
10	S152-184	Burner Door	X	
10	S152-185	Burner Door		X
11	913-0069	Flue Box Assembly	X	X
12	S501-247	Left Side (Furnace serial number required)	X	
12	S501-249	Left Side (Furnace serial number required)		X
13	127-175	Base	X	X
14	S501-246	Right Side	X	
14	S501-248	Right Side		X
15	S520-220	Burner Partition	X	
15	S520-222	Burner Partition		X
16	S542-037	Cleanout Cover Plate	X	X
17	116-157	Junction Box	X	X
18	8620-007	Cleanout Plug and Gasket	2	2
18	1921-038	Cleanout Gasket Only	2	2

FUNCTIONAL COMPONENTS

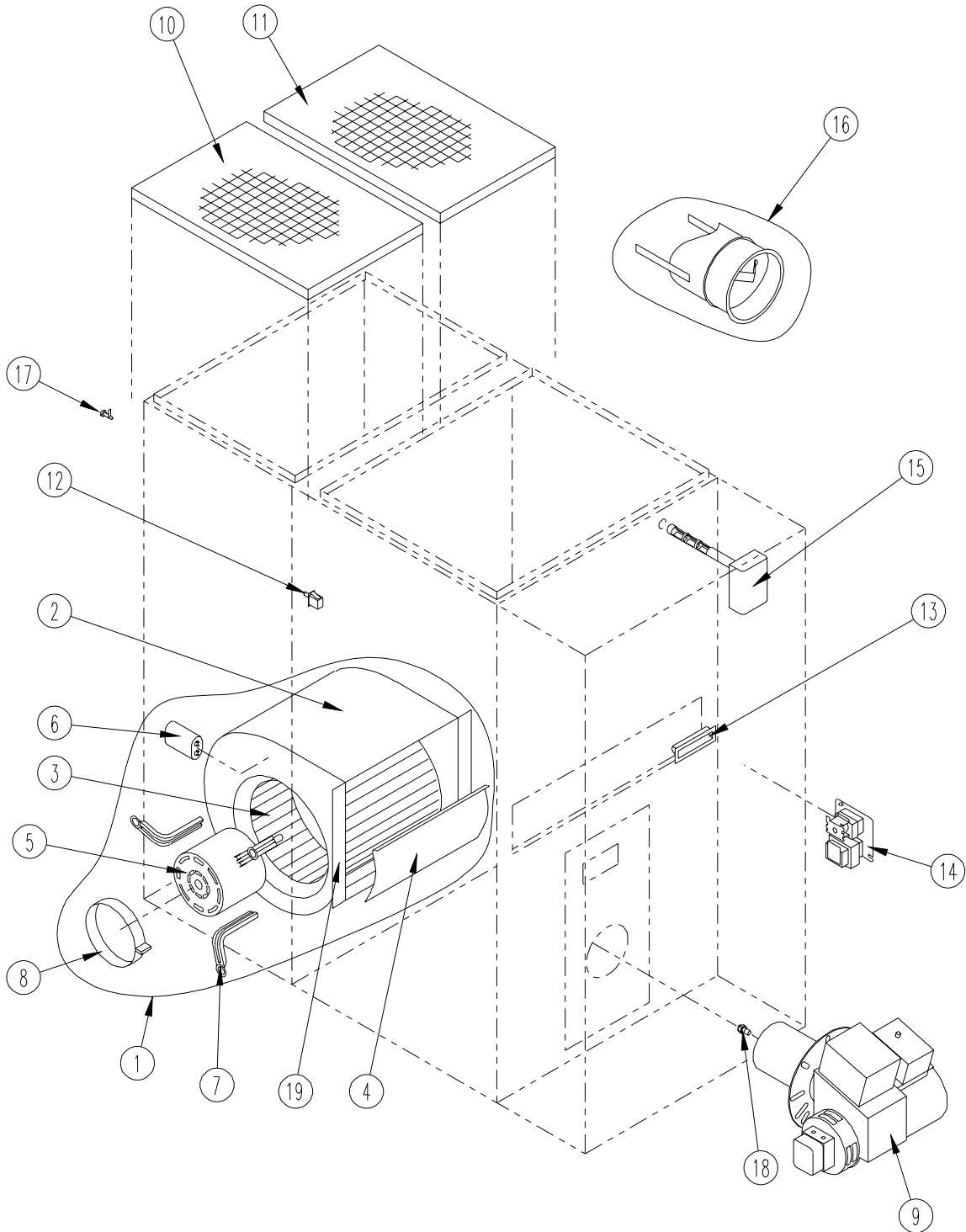

SEXP-154

FUNCTIONAL COMPONENTS

Dwg. No.	Part No.	Description	FLF085D36C	FLF110D48C
1	900-197	Blower Assembly	X	
1	900-198	Blower Assembly		X
2	151-073	Blower Housing Assembly	X	
2	151-082	Blower Housing Assembly		X
3	5152-014	Blower Wheel	X	
3	5152-059	Blower Wheel		X
4	144-128	Diffuser	X	
4	144-129	Diffuser		X
5	8105-040	Motor 1/3 HP CCW	X	
5	8106-033	Motor 1/2 HP CW		X
6	8552-002	Capacitor 5/370	X	
6	8552-004	Capacitor 7.5/370		X
7	8200-034	Motor Mount Arm	3	3
8	8200-033	Motor Mount Band	X	X
9	901-0106	Burner Assembly (Includes nozzle part no. 9011-001)	X	
9	901-0107	Burner Assembly (Includes nozzle part no. 9001-003)		X
10	7003-020	Washable Filter 11.5 x 17 x 1	X	
10	7003-021	Washable Filter 10 x 20 x 1		X
11	7003-020	Washable Filter 11.5 x 17 x 1	X	
11	7003-016	Washable Filter 13 x 20 x 1		X
12	8406-047	Door Switch		X
13	1171-025	Door Pull	2	2
14	8201-006	Fan Center	X	X
15	8620-081	Fan/Limit Control	X	X
16	8601-031	Barometric Damper	X	X
17	1171-012	Slotted Cabinet Latch	X	X
18	9011-001	Nozzle .75 GHP 80 degree	X	
18	9001-003	Nozzle 1.00 GHP 80 degree		X
19	104-794	Blower Angles	2	2
NS	4047-114	Wire Diagram	X	X

NS Not Shown

Burner Replacement Parts

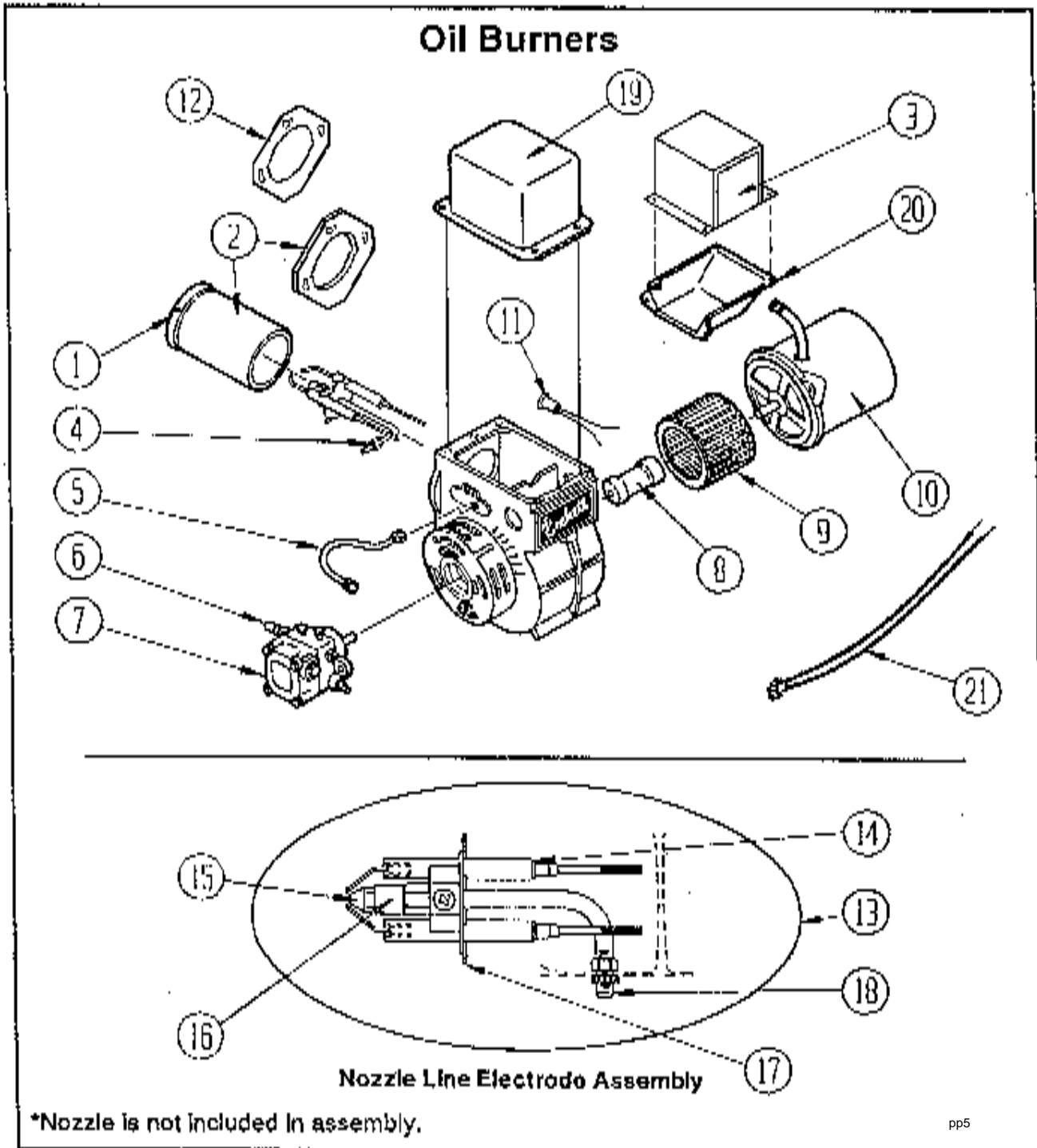

BURNER COMPONENTS

Drawing No.	Bard Part No.	Supplier Part No.	Description	FLF085D36C	FLF110D48C
1	9022-003	F3	Head	X	X
2	9022-004	51236007BK	Air Tube and Flange Assembly 7-5/8" Insertion	X	X
3	9022-056	7022U	Primary Control	X	X
4	9022-007	571801	Bulkhead Fitting	X	X
5	9022-008	5636	Connector Tube	X	X
6	9022-009	2256	Pump Outlet Elbow	X	X
7	9022-010	2460U	Pump, Single Stage	X	X
8	9022-011	2454	Coupling	X	X
9	9022-012	2459U	Blower	X	X
10	9022-013	2456U	Motor 1/7 HP 3450 RPM	X	X
11	9022-054	7006U	Cad Cell	X	X
12	9022-021	3811	Mounting Flange Gasket	X	X
13	9022-014	NL90YH	Nozzle Line Electrode Assembly	X	X
14	9022-017	5780	Electrode Insulator Assembly	X	X
15	9011-001		Nozzle .75 GPH 80 degree A	X	
15	9011-003		Nozzle 1.00 GPH 80 degree A		X
16	9022-016	213U	Nozzle Adapter Single	X	X
17	9022-023	3384P	Static Plate 3-3/8"	X	X
18	9022-018	3666	Bulkhead Fitting Locknut	X	X
19	9022-057	2442U	Ignition Transformer	X	X
20	9022-058	5770	Electrical Box Kit	X	X
21	9022-055	31838	Power Cord	X	X

BURNER/COMBUSTION CHAMBER MOUNTING SYSTEM

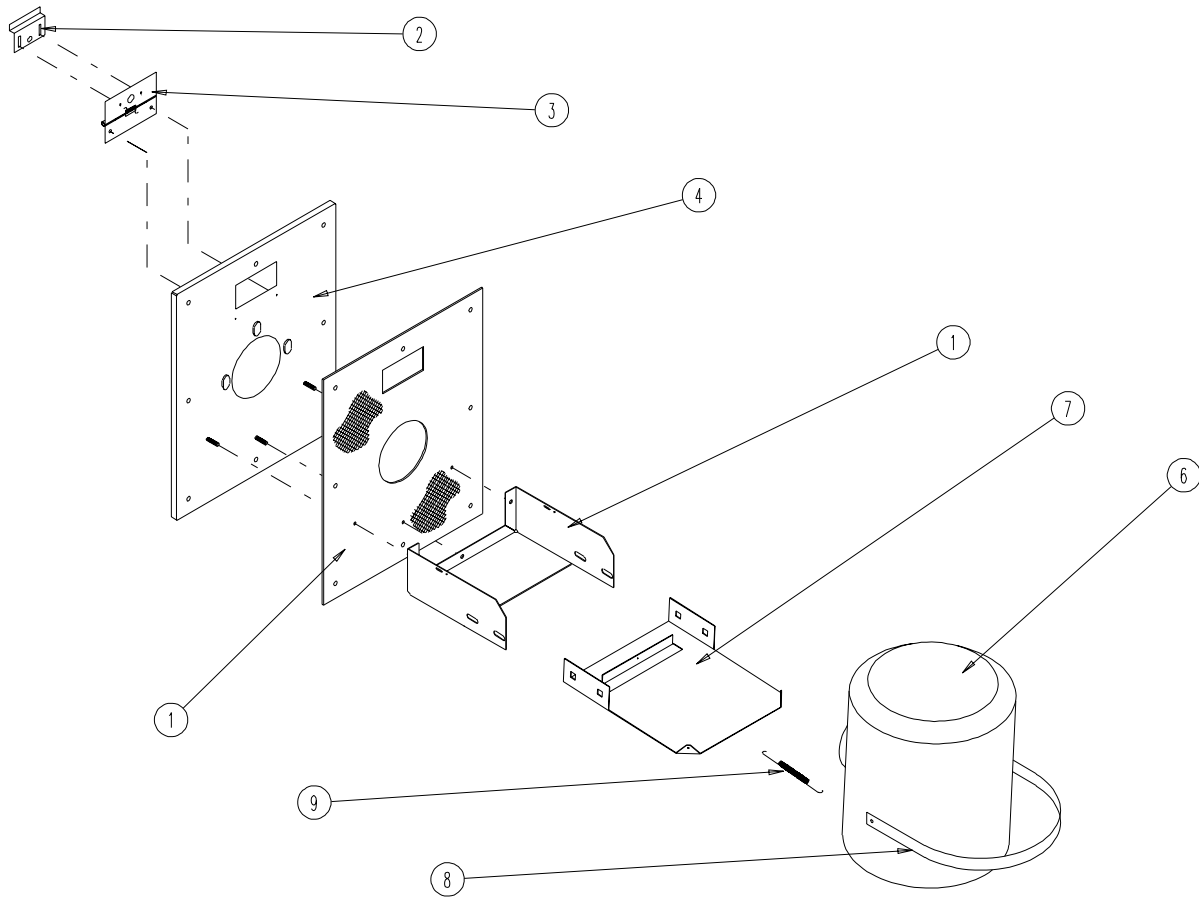

SEXP-197

BURNER/COMBUSTION CHAMBER MOUNTING SYSTEM

Dwg. No.	Part No.	Description	FLF085D36C	FLF110D48C
1	112-159	Combustion Chamber Bracket	X	X
2	142-026	Inspection Door Cover Plate	X	X
3	142-027	Inspection Door Hinge	X	X
4	161-033	Front Plate Assembly	X	X
5	1921-026	Front Plate Gasket	X	X
6	7090-005	Combustion Chamber Support	X	X
7	S112-160	Bracket Extension	X	X
8	140-198	Combustion Chamber Support	X	X
9	5401-004	Stainless Steel Spring	X	X
	S173-076	Complete Assembly of All Parts	X	X