



REPLACEMENT PARTS MANUAL UPFLOW/HORIZONTAL OIL FURNACE

MODELS: FUS150D60B, FUS200D60B

GENERAL NOTES

- * Revised and/or additional pages may be issued from time to time.
- * A complete and current manual consists of pages dated as shown in the following index.

INDEX

PAGE DESCRIPTION	PAGE	DATE	SUPERSEDES
Cabinet Components--Exploded View	1	05-02-94	
Cabinet Components--Usage List	2	01-26-95	05-02-94
Heat Exchanger/Blwr Assy.--Exploded View	3	05-02-94	
Heat Exchanger/Blwr Assy.--Usage List	4	01-26-95	05-02-94
Burner Components--Exploded View	5	01-26-95	05-02-94
Burner Components--Usage List	6	01-26-95	05-02-94
Furnace/Burner Specification Chart	7	01-26-95	05-02-94

IMPORTANT

Contact the installing and/or local Bard distributor for all parts requirements. Make sure you have the complete model and serial number available from the unit rating plates.

BARD MANUFACTURING COMPANY
Bryan, Ohio 43506

Since 1914...Moving, ahead just as planned.

Manual: 2110-916 Rev. A
Supersedes: Rev. -- None
File: 2150-004, Tab 3

CABINET COMPONENTS

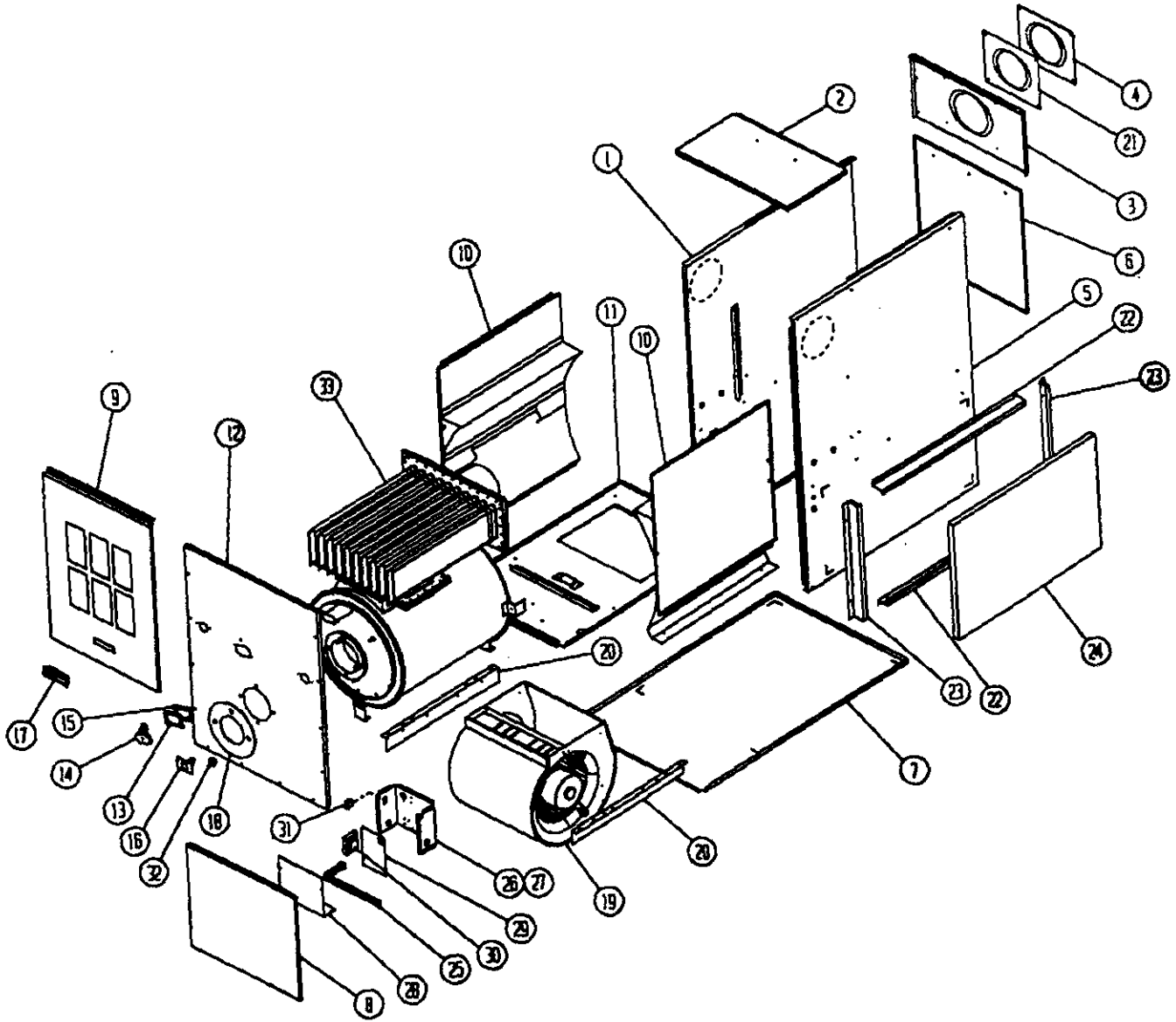

Date: 05-02-94
Supersedes:

HEAT EXCHANGER AND BLOWER ASSEMBLIES

HEAT EXANGER
ASSEMBLY

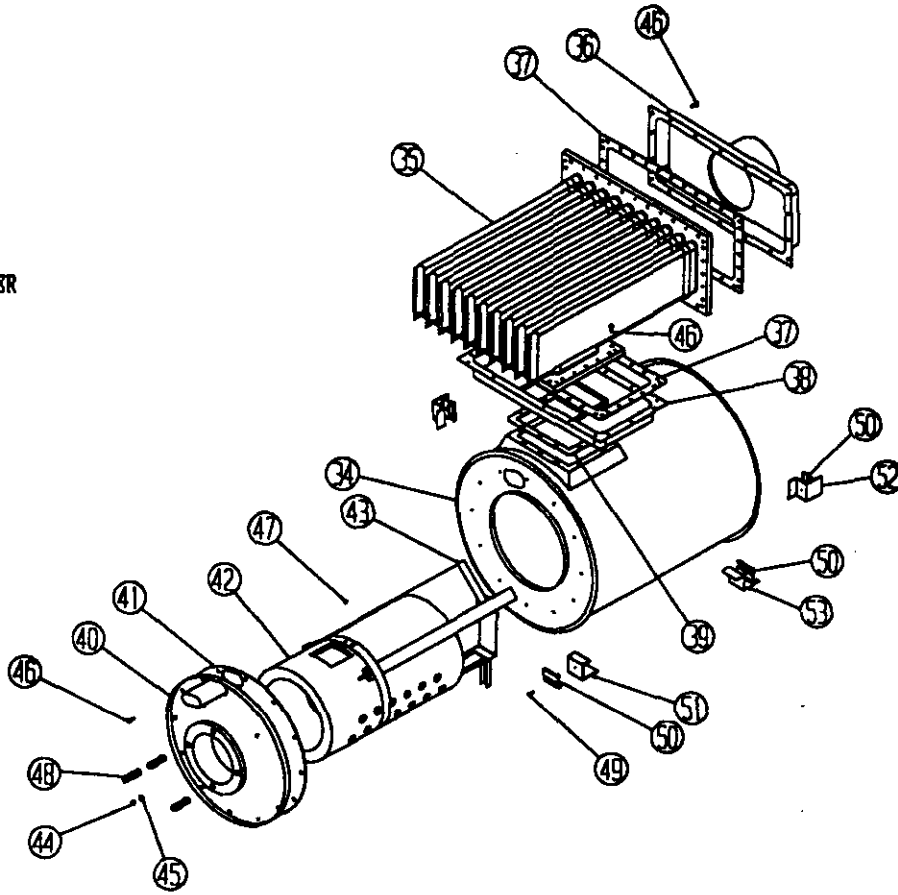

BLOWER
ASSEMBLY

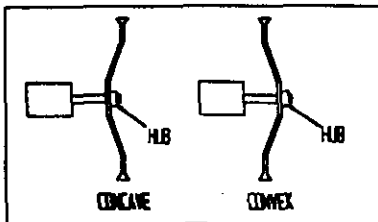
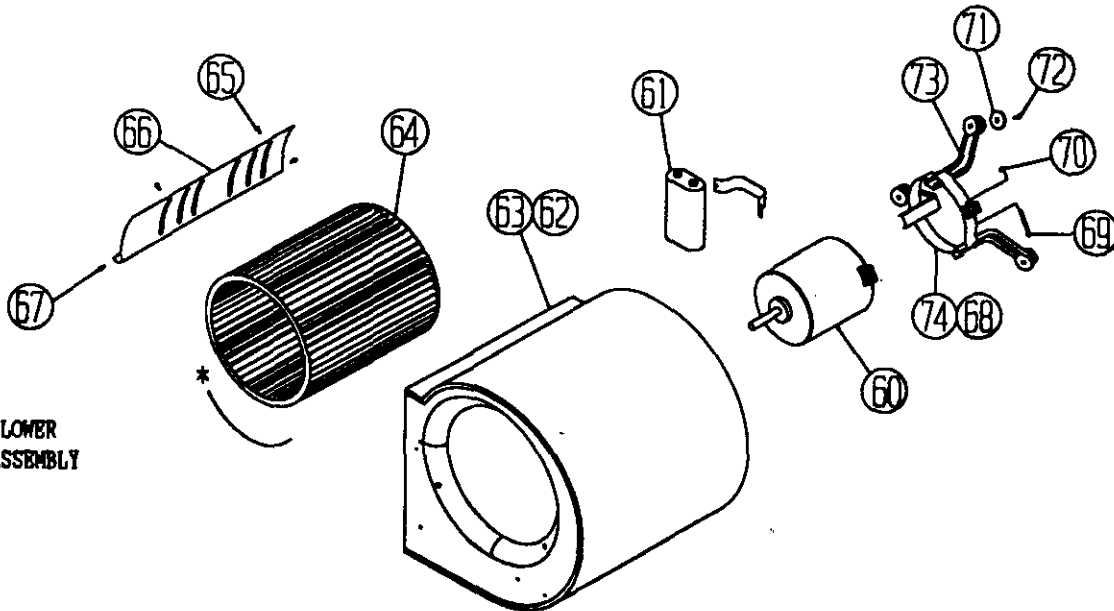

* CLOCKWISE WHEEL ROTATION AS
DETERMINED BY VIEWING HUB SIDE

Date: 05-02-94
Supersedes:

2110-916
Page: 3

HEAT EXCHANGER ASSEMBLY

Dwg. No.	Part No.	Description	FUS150D60B	FUS200D60B
34	#	Heat-X Primary Drum	X	X
35	#	Heat-X Secondary Tube Section	X	X
36	9048-163	Flue Box	X	X
37	9048-164	Gasket, Tube Plate	2	2
38	#	Box, Drum Collector	X	X
39	#	Gasket, Drum Outlet	X	X
40	9048-167	Bottom Cover Plate	X	X
41	9048-168	Gasket, Bottom Cover	X	X
42	9048-169	Combustion Chamber	X	X
43	9048-170	Band, Chamber Mounting	X	X
48	9048-171	Stud, Burner Mount	3	3
50	9048-172	Leg Clamp	4	4
51	9048-173	Bottom Front Leg	X	X
52	9048-174	Side Leg	2	2
53	9048-175	Bottom Rear Leg	X	X
54	9048-176	Draft Regulator (Not Shown)	X	X

NOTE: Items shown in exploded views and not listed are standard hardware items available in field.
included in item 33, Heat-X assembly.

BLOWER ASSEMBLY

Dwg. No.	Part No.	Description	FUS150D60B	FUS200D60B
60	9048-177	Motor, 3/4 PSC 3 Speed Direct Drive	X	X
61	9048-178	Capacitor with Boot and Clamp 15.0 MED	X	X
62	9048-179	Blower with Legs and Motor Mount 12 x 12	X	X
63	9048-180	Blower Housing 12 x 12	X	X
64	9048-181	Blower Wheel 12 x 12 Concave 1/2" Bore	X	X
66	9048-182	Cutoff 12 x 12	X	X
68	9048-183	Belly Band Motor Mount 12" Blower	X	X
73	9048-184	Motor Mount Arm 12" Blower	3	3
74	9048-185	Motor Mount Band	X	X

NOTE: Items shown in exploded views and not listed are standard hardware items available in field.

Date: 01-26-95
Supersedes: 05-02-94

BURNER COMPONENTS

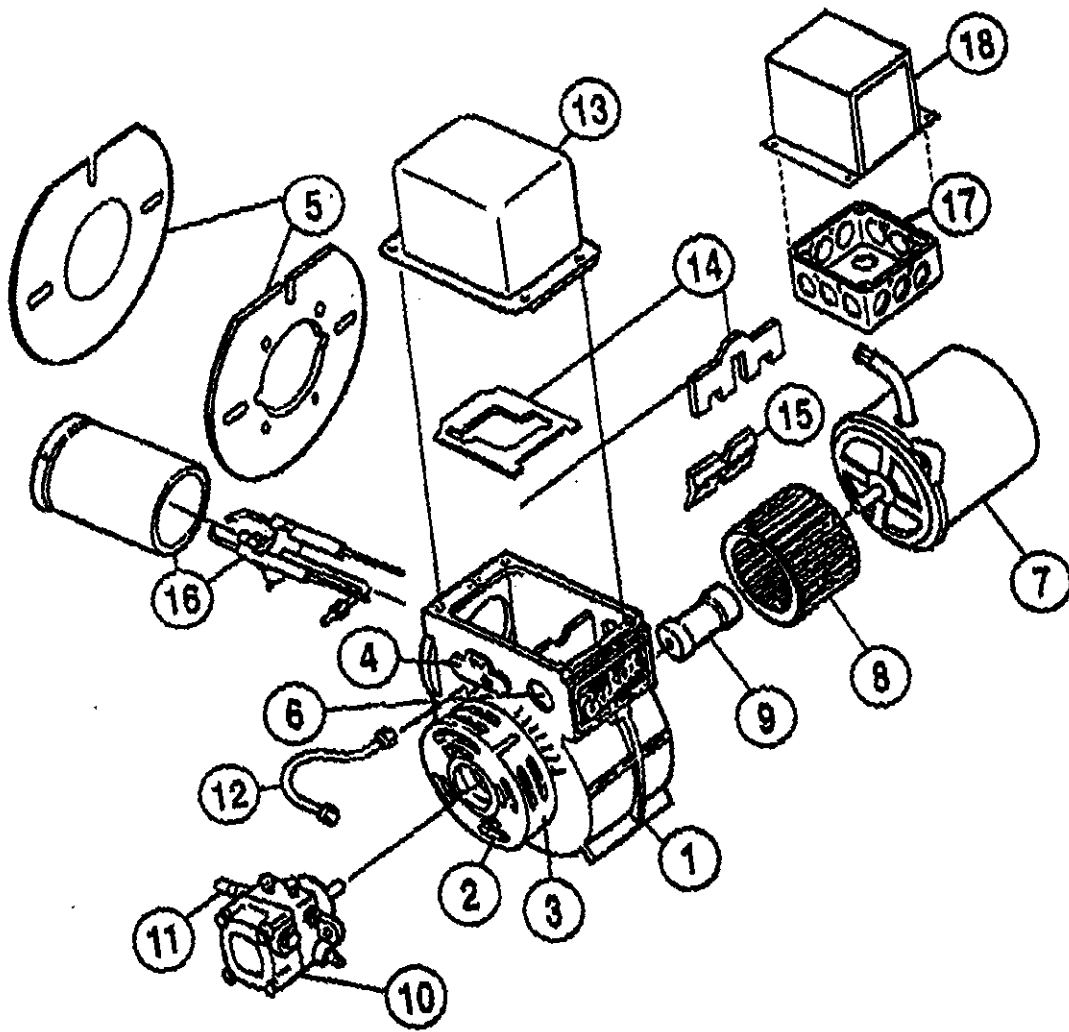

BURNER COMPONENTS

Dwg. No.	Bard Part No.	Beckett Part No.	Description	FUS150D60B	FUS200D60B
1		5877	Burner Housing Assembly	X	X
2*		3709	Air Shutter	X	X
		4198	Retaining Screw	X	X
3*		5151501	Air Band	X	X
		4198	Screw	X	X
		4150	Nut	X	X
4*		3493	Escutcheon Plate	X	X
		4292	Screw	X	X
5		31429BK	Flange	X	X
		31428	Flange, Gasket	X	X
6*		2139	Hole Plug	X	X
7	9022-013	2456	Drive Motor	X	X
		4189	Mounting Screws	X	X
8	9022-045	2999	Blower Wheel (Use Only RWB Replacement)	X	X
9	9022-011	2454	Coupling	X	X
10	9022-041	2583	Fuel Unit -- Two Stage (Suntec)	X	X
		4189	-- Mounting Screws	X	X
11	9022-009	2256	Pump Nozzle Port Fitting	X	X
12	9022-008	5636	Connector Tube Assembly	X	X
13	9022-068	5878	Ignition Transformer Assembly	X	X
			CONSISTS OF THE FOLLOWING:		
	9022-057	2442U	Ignition Transformer	X	X
		4217	Hinge Screws	X	X
		4292	Holding Screws	X	X
	9022-066	51304	Transformer Gasket Kit	X	X
14	9022-066	51304	Transformer Gasket Kit	X	X
15*		5880	Low Firing Baffle	X	X
16	9022-059	AF67XOHS	Air Tube Combination	X	X
			CONSISTS OF THE FOLLOWING:		
	9022-060	3294073BK	Air Tube	X	X
	9022-061	NL67XO	Nozzle Electrode Assembly	X	X
	9022-062	51656	Firing Head (Includes heat shield)	X	X
	9022-017	5780	Electrode Kit	X	X
17	9022-067	2362	Junction Box	X	X
18	9022-056	7022U	Primary Relay (R8184G)	X	X

* These items included in 5877 Burner Housing Assembly.
 When ordering parts--state Beckett burner model, part description and part number.

Date: 01-26-95
 Supersedes: 05-02-94

FURNACE/BURNER SPECIFICATION CHART
Beckett AFG Burner with Ignition Transformer

Bonnet Capacity	Model	Burner Spec No.	Air Tube No.	Head**	Static Plate	Air * Shutter Setting	Air * Band Setting	Nozzle	Pump Stage
150,000	Upflow/ Horizontal	DU303	AF 67XO HS	F12	2-3/4	10	1	1.35 x 70 Deg. Solid	2
200,000	Upflow/ Horizontal	DU303	AF 67XO HS	F12	2-3/4	10	1	1.75 x 70 Deg. Solid	2

* Air shutter and band settings are factory settings and must be adjusted for individual installations.
** F12 firing head 51656 (Bard 9022-062) includes ceramic Heat Shield 31517 (Bard 9022-048) and Retainer 3716 (Bard 9022-049).

Date: 01-26-95
Supersedes: 05-02-94