

REPLACEMENT PARTS MANUAL

DOWNFLOW/HORIZONTAL OIL FURNACE

MODELS: FDS055D36A, FDS075D36A,
FDS100D48A, FDS125D48A

Manual 2110-917

Revision A

Date 10-25-94

Supersedes 10-04-94

* GENERAL NOTES *

*Revised and/or additional pages may be issued from time to time.
*A complete and current manual consists of pages dated as shown in the following index.

** INDEX **

<u>Page Description</u>	<u>Page</u>	<u>Date</u>	<u>Supersedes</u>
Cabinet Components--Exploded View	1	10-04-94	
" " --Usage List	2	10-04-94	
" " --Usage List	3	10-04-94	
Heat Exchanger/Blower Assemblies--Exploded View	4	10-04-94	
" " " " -- Usage List	5	10-25-94	10-04-94

*** IMPORTANT ***

Contact the installing and/or local Bard distributor for all parts requirements. Make sure you have the complete model and serial number available from the unit rating plate.

BARD MANUFACTURING COMPANY

BRYAN, OHIO 43506

CABINET COMPONENTS

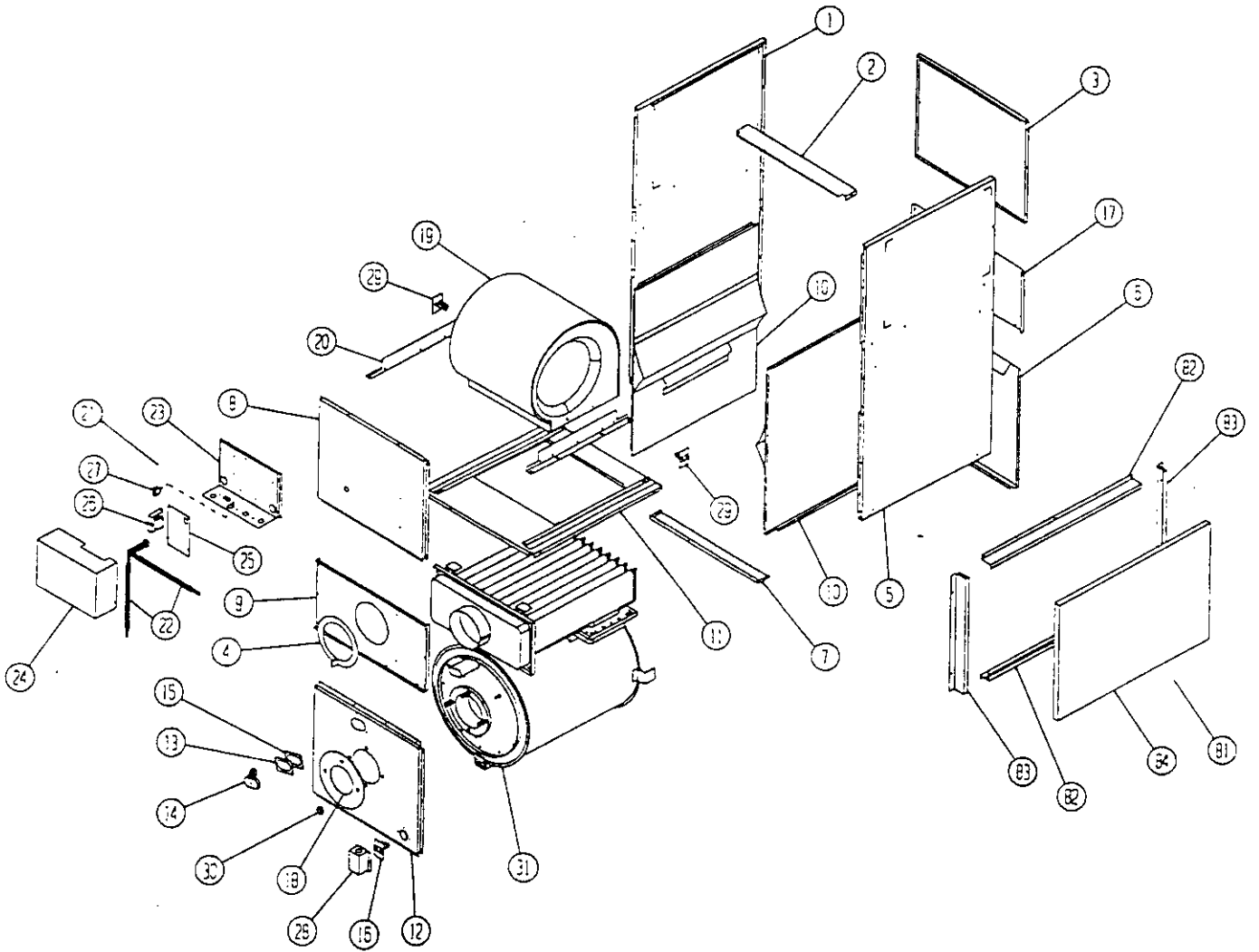

Date: 10-04-94
Supersedes:

CABINET COMPONENTS

Dwg. No.	Part No.	Description	FDS055D36A FDS075D36A	FDS100D48A	FDS125D48A
1	9048-186	Left Side Panel (Includes No. 10)	X		
1	9048-187	Left Side Panel (Includes No. 10)		X	X
2	9048-188	Top Panel	X		
2	9048-189	Top Panel		X	X
3	9048-190	Back Top Panel	X		
3	9048-191	Back Top Panel		X	X
4	9048-192	Rosette, Flue Outlet	X	X	X
5	9048-193	Right Side Panel (Includes No. 10)	X		
5	9048-219	Right Side Panel (Includes No. 10)		X	X
6	9048-194	Back Bottom Panel	X		
6	9048-195	Back Bottom Panel		X	X
7	9048-196	Base Panel	X		
7	9048-197	Base Panel		X	X
8	9048-198	Blower Door	X		
8	9048-199	Blower Door		X	X
9	9048-200	Front Center Panel	X		
9	9048-201	Front Center Panel		X	X
10	9048-202	Side Shield	2		
10	9048-203	Side Shield		2	2
11	9048-204	Partition Panel	X		
11	9048-205	Partition Panel		X	
11	9048-206	Partition Panel			X
12	9048-207	Front Bottom Panel	X		
12	9048-208	Front Bottom Panel		X	X
13	9048-140	Rosette Observation Tube	X	X	X
14	9048-141	Observation Door	X	X	X
15	9048-142	Gasket, Rosette Observation Tube	X	X	X
16	9048-209	Limit Control (170) w/Insulator	X		
16	9048-210	Limit Control (195) w/Insulator		X	X
17	9048-211	Back Center Panel	X		
17	9048-212	Back Center Panel		X	X
18	9048-145	Burner Mounting Gasket	X	X	X
19	9048-213	Blower Assembly with 1/3 HP PSC Motor	X		
19	9048-214	Blower Assembly with 1/2 HP PSC Motor		X	
19	9048-215	Blower Assembly with 3/4 HP PSC Motor			X
20	9048-216	Leg, Blower	2		
20	9048-217	Leg, Blower		2	2
21	9048-218	Control Assembly (Includes No. 23 - 27)	X	X	X
22	9048-220	Wire Harness (Burner and Control Cables)	X	X	X
23	9048-221	Control Box	X	X	X
24	9048-222	Cover, Control Box	X	X	X
25	9048-157	Control, Fan Timer	X	X	X
26	9048-158	Transformer, 40VA	X	X	X
27	9048-159	Continuous Low Speed Fan Switch	X	X	X
28	9048-223	Cover, Limit	X	X	X
29	9048-224	Reverse Flow Limit (140) w/Insulator	2	2	2
31	9048-225	Heat Exchanger (Includes No. 32 - 51)	X		
31	9048-226	Heat Exchanger (Includes No. 32 - 51)		X	
31	9048-227	Heat Exchanger (Includes No. 32 - 51)			X

NOTE: Items shown in exploded views and not listed are standard hardware items available in the field.

Date: 10-04-94

Supersedes:

2110-917

Page: 2

CABINET COMPONENTS

Dwg. No.	Part No.	Description	FDS055D36A FDS075D36A	FDS100D48A	FDS125D48A
80	9048-250	Combustible Floor Sub-Base	x		
80	9048-251	Combustible Floor Sub-Base		x	x
81	9048-252	Filter Rack w/Filter (Includes 82 - 84)	x		
81	9048-253	Filter Rack w/Filter (Includes 82 - 84)		x	x
82	9048-254	Filter Top and Bottom Panel	2		
82	9048-255	Filter Top and Bottom Panel		2	2
83	9048-256	Filter Rear and Access Panel	2		
83	9048-150	Filter Rear and Access Panel		2	2
84	9048-257	Filter	x		
84	9048-258	Filter		x	x

NOTE: Items shown in exploded views and not listed are standard hardware items available in the field.

Date: 10-04-94
Supersedes:

2110-917
Page: 3

HEAT EXCHANGER AND BLOWER ASSEMBLIES

HEAT EXCHANGER
ASSEMBLY

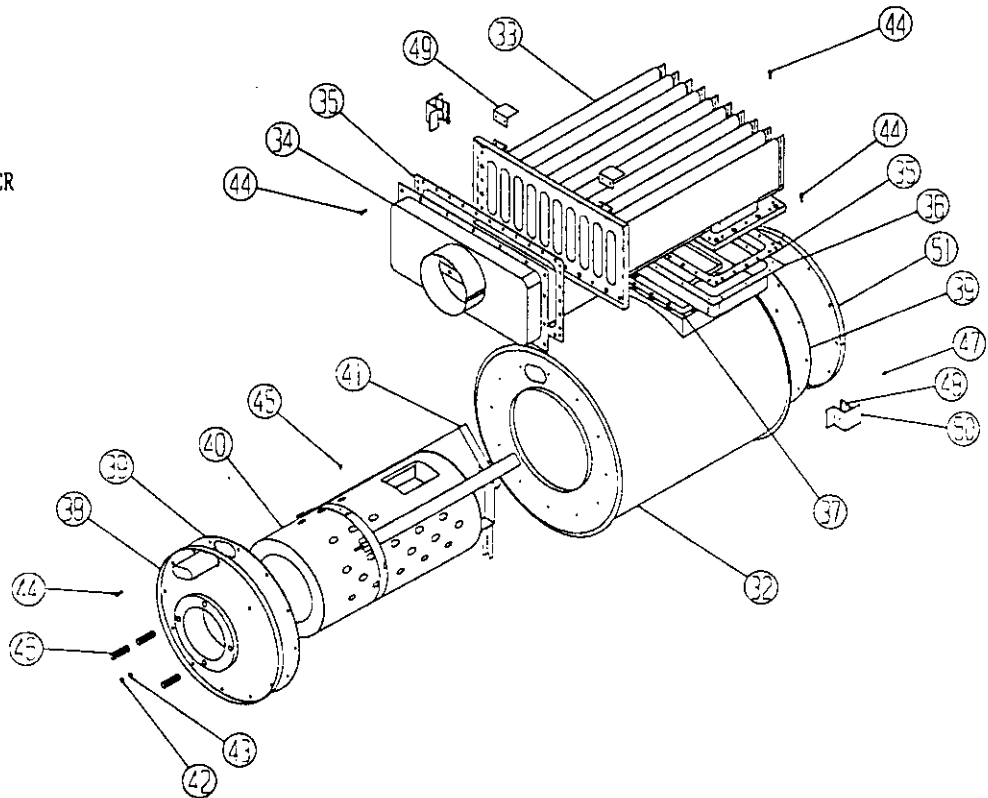

BLOWER
ASSEMBLY

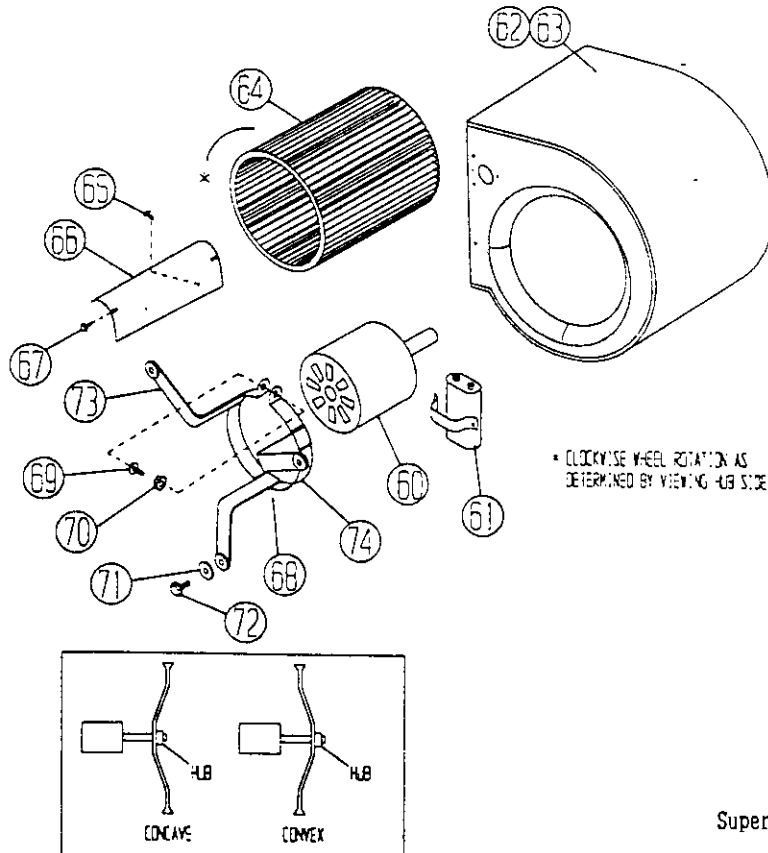

Date: 10-04-94
Supersedes:

HEAT EXCHANGER ASSEMBLY

Dwg. No.	Part No.	Description	FDS055D36A FDS075D36A	FDS100D48A	FDS125D48A
32		Heat-X Primary Drum	(Included in Item 31, Heat-X Assembly)		
33		Heat-X Secondary Tube Section	(Included in Item 31, Heat-X Assembly)		
34	9048-228	Flue Box	x		
34	9048-229	Flue Box		x	x
35	9048-230	Gasket, Tube Plate	2		
35	9048-164	Gasket, Tube Plate		2	2
36		Box, Drum Collector	(Included in Item 31, Heat-X Assembly)		
37		Gasket, Drum Outlet	(Included in Item 31, Heat-X Assembly)		
38	9048-231	Bottom Cover Plate	x		
38	9048-232	Bottom Cover Plate		x	x
39	9048-233	Gasket, Bottom Cover	2	2	2
40	9048-234	Combustion Chamber	x		
40	9048-235	Combustion Chamber		x	
40	9048-259	Combustion Chamber			x
41	9048-236	Band, Combustion Mounting	x		
41	9048-237	Band, Combustion Mounting		x	
41	9048-238	Band, Combustion Mounting			x
46	9048-171	Stud, Burner Mount	3	3	3
48	9048-172	Leg Clamp	2	2	2
49	9048-239	Angle Clamp	2	2	2
50	9048-174	Side Leg	2	2	2
51	9048-240	Rear Cover Plate	x	x	x
52	9048-176	Draft Regulator (Not Shown)	x	x	x

NOTE: Items shown in exploded views and not listed are standard hardware items available in the field.

BLOWER ASSEMBLY

Dwg. No.	Part No.	Description	FDS055D36A FDS075D36A	FDS100D48A	FDS125D48A
60	9048-241	Motor, 1/3 PSC 3 Speed Direct Drive	x		
60	9048-242	Motor, 1/2 PSC 3 Speed Direct Drive		x	
60	9048-177	Motor, 3/4 PSC 3 Speed Direct Drive			x
61	9048-243	7.5 MFD Capacitor w/Boot and Clamp	x		
61	9048-178	15.0 MFD Capacitor w/Boot and Clamp		x	x
62	9048-244	12 x 9 DD Blower w/Legs and Motor Mount	x		
62	9048-245	12 x 9 DD Blower w/ Legs and Motor Mount		x	
62	9048-260	12 x 12 DD Blower w/Legs and Motor Mount			x
63	9048-246	Blower Housing 12 x 9 TR	x	x	
63	9048-247	Blower Housing 12 x 12 TR			x
64	9048-248	Blower Wheel 12 x 9 Convex 1/2" Bore	x	x	
64	9048-181	Blower Wheel 12 x 12 Concave 1/2" Bore			x
66	9048-249	Cutoff 12 x 9	x	x	
66	9048-182	Cutoff 12 x 12			x
68	9048-183	Belly Band Motor Mount 12" Blower	x	x	x
73	9048-184	Motor Mount Arm 12" Blower	3	3	3
74	9048-185	Motor Mount Band	x	x	x

NOTE: Items shown in exploded views and not listed are standard hardware items available in the field.

Date: 10-25-94
Supersedes: 10-04-94
2110-917