



# 1980 Parts List

## Pink Pages

### SPLIT SYSTEM CONDENSING UNITS

18ECQ1 24ECQ1 30ECQ2 31ECQ 36ECQ4 36ECQ4-3 37ECQ 42ECQ 42ECQ-3 48ECQ1 48ECQ1-3  
60ECQ1 60ECQ1-3 ---1

### WALL MOUNT AND PACKAGED A/C UNITS

20WA1 24WA2 ---2

30WA2 36WA4 36WA4-3 ---3

42WA 42WA-3 49WA 49WA-3 ---4

P24A1 P30A1 ---5

P36A4 P36A4-3 ---6

P48A4 P48A4-3 P60A4 P60A4-3 ---7

MU32A MU36B MU42B MU48 MU60 ---8-9

RPM18 RPM24-1 RPM30 ---10

### WALL MOUNT AND PACKAGED HEAT PUMP UNITS

18WH2 24WH2 ---13

30WH1 36WH2 36WH2-3 ---14-15

48WH1 48WH1-3 ---16

PH24 PH30 ---17

PH31-1 PH36-2 PH36-2-3 ---18-19

PH48-1 PH48-1-3 PH60-1 PH60-1-3 ---20-21

MH30 MH36 ---22

RPMH30 RPMH30-3 RPMH36 RPMH36-3 ---23-24

### SPLIT SYSTEM HEAT PUMPS

18HPQ1 24HPQ1 30HPQ3 36HPQ3 36HPQ3-3 42HPQ 42HPQ-3 48HPQ2 48HPQ2-3 60HPQ3  
60HPQ3-3 ---11-12



# 1980 Parts List

## Pink Pages

### SPLIT SYSTEM BLOWER COILS

B18EQ1 B24EQ1 B18EHQ B24EHQ B36EHQ B48EHQ B60EHQ ---25-26

### ELECTRIC FURNACES

EFC10 EFC10-B EFC15 EFC20 EFC25 EFC30 ---27

### GAS FURNACES

G101 G127 G152 ---28

G101E G127E G152E ---29

H61SD2 H81SD2 H81SD3 H106S H106SD2 H106SD3 H121S H121SD4 H141S H161S H201S ---30-31

H61SD2E H81SD2E H81SD3E H106SE H106SD2E H106SD3E H121SE H121SD4E H141SE H161SE H201SE ---32-33

C61SD2 C81SD2 C106SD3 C106S C121S C141S C161S ---34-35

C61SD2E C81SD2E C106SD3E C106SE C121SE C141SE C141S1E C161SE C161S1E ---36-37

HG75D4 HG100D4 HG120D4 HG140D4 HG160D2 ---38

HG75D4E HG100D4E HG120D4E HG140D4E HG160D2E ---39-40

### OIL FURNACES

F81 F97 NB120 C1 C2 F86CF F100CF F86H F120H F120L HZ95 ---41-42

SO175 SO230 SO350 S0175 S0230 S0350 ---43-44

MSR-8 MSR-6 ---45-54

OEA-6 OEA-8 ---55-58

WP20 WP40 ---59

### AIR CLEANERS

EC14 EC20 ---60



# **PARTS LIST**

**Air Conditioners**

**Heat Pumps**

**Furnaces**

**(Gas - Oil - Electric)**

**Blower Coils**

**Air Cleaners**

**EFFECTIVE 1/1/80  
SUPERSEDES 1/1/79**

## **IMPORTANT**

**Retain obsolete parts lists for reference purposes. It is essential to use complete model number and matching parts list to help assure the correct part is shipped.**

PARTS LIST  
SPLIT SYSTEM CONDENSING UNITS

Effective 1/1/80  
Supersedes 1/1/79

PART NO.	DESCRIPTION	18ECQ1	24ECQ1	30ECQ2	31ECQ	36ECQ4	36ECQ4-3	37ECQ	42ECQ	42ECQ-3	48ECQ1	48ECQ1-3	60ECQ1	60ECQ1-3	36ECQ4-3 460V	48ECQ1-3 460V	60ECQ1-3 460V
8552-015	Capacitor 25/370V	x			x			x									
8552-007	Capacitor 20/15-370V		x	x													
8552-012	Capacitor 35/440V					x			x								
8552-009	Capacitor 25/15-440V										x						
8552-017	Capacitor 45/440V												x				
8552-005	Capacitor 10/370V							x	x	x	x	x	x			x	x
8552-022	Capacitor 20/370V				x												
8552-024	Capacitor 40/370V							x									
8552-002	Capacitor 5/370V	x	x	x	x	x	x	x									
8000-001	Compressor AB111FT	x															
8000-002	Compressor AB114FT		x														
8000-006	Compressor AH152GT			x													
8000-050	Compressor H2EA253AB				x												
8000-008	Compressor AH301FT					x											
8000-051	Compressor H2EA363AB							x									
8000-009	Compressor AH302RT						x			x							
8000-011	Compressor YRB4-0300								x								
8000-013	Compressor YRC4-0350										x						
8000-015	Compressor YRC4-0350											x					
8000-027	Compressor AG122ET												x				
8000-031	Compressor AG122RT													x			
8000-010	Compressor AH302TT														x		
8000-040	Compressor CL157TT															x	
8000-048	Compressor AG122UT																x
5051-011	Condenser Coil	x															
5051-013	Condenser Coil		x														
5051-001	Condenser Coil			x		x	x								x		
5051-023	Condenser Coil				x			x									
5051-009	Condenser Coil								x	x	x	x				x	
5051-024	Condenser Coil												x	x			x
8401-007	Contactator - Comp. 25A	x	x	x	x			x									
8401-003	Contactator - Comp. 30A					x			x		x						
8401-002	Contactator - Comp. 25A						x			x		x		x	x	x	x
8401-016	Contactator - Comp. 35A												x				
8605-001	Crankcase Heater						x			x		x					
8605-002	Crankcase Heater														x	x	
5151-001	Fan Blade TF1839	x	x														
5151-007	Fan Blade TP2029			x	x	x	x	x							x		
5151-017	Fan Blade FA2430-4B								x	x	x	x	x	x		x	x
8406-010	High Pressure Switch															x	
8103-008	Motor - Fan 1/5	x	x														
8103-009	Motor - Fan 1/5			x	x	x	x	x							x		
8105-005	Motor - Fan 1/3								x	x	x	x	x	x		x	x
8200-001	Motor Mount - Fan	x	x	x	x	x	x	x							x		
8200-004	Motor Mount - Fan								x	x	x	x	x	x		x	x
607-002	Terminal Block 230V														x	x	x
407-003	Transformer-Stepdown														x	x	x

Minimum Net Billing \$15.00. Supersedes all previous lists.  
Subject to change without notice. F.O.B. Bryan, Ohio

PARTS LIST  
SINGLE PACKAGE AIR CONDITIONERS

Effective 1/1/80  
Supersedes 1/1/79

PART NO.	DESCRIPTION	20WA1	24WA2
5152-030	Blower Housing 9-7	x	x
5152-028	Blower Wheel 9-7	x	x
5152-029	Blower Wheel 9-7	x	x
8552-027	Capacitor 25/370V	x	x
8552-002	Capacitor 5/370V	x	x
5811-021	Capillary Tube - Cool	x	
5811-020	Capillary Tube - Cool		x
8000-061	Compressor RES3-0175-PFV-270	x	
8000-062	Compressor AB224FT-014-A4		x
5051-017	Condenser Coil	x	
5051-025	Condenser Coil		x
8401-007	Contactactor - Comp. 25A	x	x
8401-006	Contactactor - Heater 2P18	x	x
5060-024	Evaporator Coil	x	x
5151-024	Fan Blade A-1831-5	x	x
7004-006	Filter 14x25	x	x
8604-041	Heat Strip 4Kw	x	x
8604-042	Heat Strip 5Kw	x	x
8604-043	Heat Strip 8Kw	x	x
8604-044	Heat Strip 10Kw	x	x
8402-029	Limit Switch 160°	x	x
8102-008	Motor - Blower 1/6 hp	x	x
8103-009	Motor - Fan 1/5 hp	x	x
8552-004	Capacitor 7.5/370V	x	x
8200-023	Motor Mount - Fan	x	x
5210-002	Strainer	x	x
8201-009	Relay - Blower	x	x
8607-006	Terminal Board 24V	x	x
8607-001	Terminal Block 230V	x	x
8402-030	Thermal Cut-off	x	x
8407-007	Transformer 40VA	x	x

Minimum Net Billing \$15.00. Supersedes all previous lists.  
Subject to change without notice. F.O.B. Bryan, Ohio.

PARTS LIST  
SINGLE PACKAGE AIR CONDITIONERS

Effective 1/1/80  
Supersedes 1/1/79

PART NO.	DESCRIPTION	30WA2	36WA4	36WA4-3	36WA4-3 460V
5152-030	Blower Housing 9-7	x	x	x	x
5152-028	Blower Wheel 9-7	x	x	x	x
5152-029	Blower Wheel 9-7	x	x	x	x
8552-022	Capacitor 20/370V	x			
8552-020	Capacitor 35/370V	x			
8552-024	Capacitor 40/370V		x		
8552-002	Capacitor 5/370V	x	x	x	x
5811-014	Cap Tube - Cool 37-1/2" x .070	(2)			
5811-033	Cap Tube - Cool 32" x .070		(2)	(2)	(2)
8000-042	Compressor H2EA293AB	x			
8000-055	Compressor CRH1-0275-PFV-270		x		
8000-056	Compressor CRH1-0275-TF5-270			x	
8000-057	Compressor CRH1-0275-TFD-270				x
5051-020	Condenser Coil	x			
5051-023	Condenser Coil		x	x	x
8401-007	Contactoer - Comp. 1P25A	x	x		
8401-002	Contactoer - Comp. 3P25A			x	x
8401-006	Contactoer - Heater 2P18A	x	x	x	
5060-023	Evaporator Coil	x	x	x	x
5151-025	Fan Blade F10H08-2027 cw	x	x	x	x
7004-008	Filter 15 x 30-5/8	x	x	x	x
8614-006	Fuse - Heater 30A	x	x		
8614-022	Fuse - Compressor 60A	x	x		
8614-017	Fuse Block 15Kw	x	x		
8604-042	Heat Strip 5Kw	x	x		
8604-049	Heat Strip 6Kw			x	
8604-044	Heat Strip 10Kw	x	x		
8604-048	Heat Strip 9Kw			x	
8604-046	Heat Strip 12Kw			x	
8604-047	Heat Strip 15Kw	x	x	x	
8604-050	Heat Strip 9Kw				x
8604-051	Heat Strip 12Kw				x
8604-052	Heat Strip 15Kw				x
8402-031	Limit Switch L155-2.5	x	x	x	x
8105-019	Motor - Blower 1/3 hp	x	x	x	
8105-015	Motor - Blower 1/3 hp				x
8105-020	Motor - Fan 1/3 hp	x	x	x	
8105-016	Motor - Fan 1/3 hp				x
8200-001	Motor Mount - Fan	x	x	x	x
8201-009	Relay - Blower	x	x	x	
8201-032	Relay - Blower				x
5210-004	Strainer	x	x	x	x
8607-006	Terminal Board 24V	x	x	x	x
8607-001	Terminal Block 230V	x	x		
8607-002	Terminal Block			x	x
8607-007	Terminal Board				x
8402-032	Thermal Cut-off	x	x	x	x
8407-007	Transformer	x	x		
8407-015	Transformer			x	
8407-027	Transformer				x
8552-003	Capacitor 6/370V	x	x		
8552-001	Capacitor 4/370V			x	x

Minimum Net Billing \$15.00. Supersedes all previous lists.  
Subject to change without notice. F.O.B. Bryan, Ohio

PARTS LIST  
SINGLE PACKAGE AIR CONDITIONERS

Effective 1/1/71  
Supersedes 1/1/71

PART NO.	DESCRIPTION	42WA	42WA-3	49WA	49WA-3	42WA-3 460V	49WA-3 460V
*	Blower Housing	x	x	x	x	x	x
5152-011	Blower Wheel DD10-8A	x	x	x	x	x	x
5152-012	Blower Wheel DD10-8A	x	x	x	x	x	x
8552-012	Capacitor - Comp. 35/440V	x					
8552-005	Capacitor - Blower	x	x	x	x	x	x
8552-026	Capacitor - Fan	x	x	x	x	x	x
8552-016	Capacitor - Comp.			x			
5811-021	Capillary Tube - Cool	(2)	(2)			(2)	
5811-020	Capillary Tube - Cool			(2)	(2)		(2)
8000-058	Compressor CRJ1-0300-PFV-270	x					
8000-059	Compressor CRJ1-0300-TF5-270		x				
8000-063	Compressor CRK1-0325-PFV-270			x			
8000-064	Compressor CRK1-0325-TF5-270				x		
8000-060	Compressor CRJ1-0300-TFD-270					x	
8000-065	Compressor CRK1-0325-TFD-270						x
5051-027	Condenser Coil	x	x			x	
5051-028	Condenser Coil			x	x		x
8401-007	Contacto - Comp. 25A	x					
8401-002	Contacto - 25A		x		x	x	x
8401-006	Contacto - Heater 24V	x	x	x	x		
8401-003	Contacto - Comp. 30A			x			
5060-025	Evaporator Coil	x	x	x	x	x	x
5151-021	Fan Blade B2430-4 ccw	x	x	x	x	x	x
7004-010	Filter 16x20	x	x	x	x	x	x
8614-017	Fuse Block 15Kw	x		x			
8614-013	Fuse Block 20Kw	x		x			
8614-022	Fuse 60A	x		x			
8614-006	Fuse 30A	x		x			
8614-007	Fuse 60A	x		x			
8604-042	Heat Strip 5Kw	x		x			
8604-044	Heat Strip 10Kw	x		x			
8604-047	Heat Strip 15Kw	x		x			
8604-048	Heat Strip 9Kw		x		x		
8604-046	Heat Strip 12Kw		x				
8604-050	Heat Strip 9Kw						
8604-051	Heat Strip 12Kw					x	x
8402-029	Limit Switch L160-2.5	x	x	x	x	x	x
8106-014	Motor - Blower 1/2 hp	x	x	x	x	x	x
8105-021	Motor - Fan 1/3 hp	x	x	x	x	x	x
8201-009	Relay - Blower	x	x	x	x		
8201-008	Relay - Blower Heat/Cool					x	x
8200-004	Motor Mount - Fan	x	x	x	x	x	x
5210-005	Strainer	x	x	x	x	x	x
8607-005	Terminal Board 24V	x	x	x	x	x	x
8607-001	Terminal Block 230V	x		x		x	x
8607-002	Terminal Block 230V		x		x	x	x
8402-032	Thermal Cuf-off	x	x	x	x	x	
8407-007	Transformer 40VA	x		x			
8407-015	Transformer 55VA		x		x	x	x
8407-004	Transformer - Stepdown					x	x

PARTS LIST  
SINGLE PACKAGE AIR CONDITIONERS

Effective 1/1/80  
Supersedes 1/1/79

PART NO.	DESCRIPTION	P24A1	P30A1
5152-020	Blower Housing S1110-6	x	x
5152-009	Blower Wheel 10 x 5-1/2	x	x
8552-007	Capacitor 20/15-370V	x	x
8552-002	Capacitor 5/370V	x	x
5811-021	Capillary Tube	x	
5811-026	Capillary Tube		x
8000-002	Compressor AB114FT	x	
8000-006	Compressor AH152GT		x
5051-006	Condenser Coil	x	x
8401-007	Contacto - Compressor 25A	x	x
8401-006	Contacto - Heater 20A	x	x
5060-005	Evaporator Coil	x	x
5151-009	Fan Blade FF1827-4	x	x
8604-042	Heat Strip 5Kw	x	x
8604-044	Heat Strip 10Kw	x	x
8402-015	Limit Switch	x	x
8106-005	Motor - Blower & Fan 1/2 hp	x	x
8200-010	Motor Cradle	x	x
8201-009	Relay - Blower	x	x
5210-002	Strainer	x	x
8607-006	Terminal Board 24V	x	x
8607-001	Terminal Block 230V	x	x
8402-026	Thermal Cut-off	x	x
8407-007	Transformer	x	x

Minimum Net Billing \$15.00. Supersedes all previous lists  
Subject to change without notice. F.O.B. Bryan, Ohio.



PARTS LIST  
SINGLE PACKAGE AIR CONDITIONERS

Effective 1/1/80  
Supersedes 1/1/79

PART NO.	DESCRIPTION	P36A4	P36A4-3	P36A4-3 460V
*	Blower Housing SI110-6	x	x	x
5152-013	Blower Wheel DD10-8A	x	x	x
8552-024	Capacitor - Compressor 40/370V	x		
8552-015	Capacitor - Compressor 25/370V	x		
8552-002	Capacitor - Fan & Blower 5/370V	x	x	x
5811-033	Capillary Tube - Cool	(2)	(2)	(2)
8000-051	Compressor H2EA363AB	x		
8000-056	Compressor CRH1-0275-TF5-270		x	
8000-057	Compressor CRH1-0275-TFD-270			x
5051-023	Condenser Coil	x	x	x
8401-007	Contactator - Comp. 1P25A	x		
8401-002	Contactator - Comp. 3P25A		x	x
8401-006	Contactator - Heater 2P20	x	x	
5060-023	Evaporator Coil	x	x	x
5151-004	Fan Blade TP2026 ccw	x	x	
5151-025	Fan Blade F10H08-2027 cw			x
8614-017	Fuse Block 15Kw	x		
8614-022	Fuse 60A	x		
8614-006	Fuse 30A	x		
8604-042	Heat Strip 5Kw	x		
8604-044	Heat Strip 10Kw	x		
8604-047	Heat Strip 15Kw	x	x	
8604-048	Heat Strip 9Kw		x	
8604-046	Heat Strip 12Kw		x	
8604-050	Heat Strip 9Kw			x
8604-052	Heat Strip 15Kw			x
8402-012	Limit Switch 130°	x	x	x
8105-020	Motor - Blower 1/3 hp ccw	x	x	
8105-018	Motor - Blower 1/3 hp ccw			x
8103-009	Motor - Fan 1/5 hp cw	x	x	
8105-016	Motor - Fan 1/3 hp ccw			x
8200-003	Motor Mount - Blower	x	x	x
8200-001	Motor Mount - Fan	x	x	x
5451-011	Motor Mounting Parts	x	x	x
8201-009	Relay - Blower	x	x	
8201-032	Relay - Blower			x
5210-004	Strainer	x	x	x
8607-006	Terminal Board 24V	x	x	x
8607-001	Terminal Block 230V	x		
8607-002	Terminal Block 230V		x	x
8402-026	Thermal Cutoff	x	x	x
8407-007	Transformer 40VA	x		
8407-015	Transformer 55VA		x	
8407-027	Transformer 48VA			x

\*Please order by model number

Minimum Net Billing \$15.00. Supersedes all previous lists.  
Subject to change without notice. F.O.B. Bryan, Ohio.

PARTS LIST  
SINGLE PACKAGE AIR CONDITIONERS

Effective 1/1/80  
Supersedes 1/1/79

PART NO.	DESCRIPTION	P48A4	P48A4-3	P60A4	P60A4-3	P48A4-3 460V	P60A4-3 460V
*	Blower Housing 10-10	x	x	x	x	x	x
5152-015	Blower Wheel DD10-10A	x	x	x	x	x	x
8552-016	Capacitor 40/440V	x					
8552-005	Capacitor 10/370V	x	x	x	x	x	x
8552-026	Capacitor 15/370V	x	x			x	
8552-017	Capacitor 45/440V			x			
8552-004	Capacitor 7-1/2/370V			x	x		x
5811-020	Capillary Tube - Cool	(2)	(2)			(2)	
5811-032	Capillary Tube - Cool			(2)	(2)		(2)
8000-063	Compressor CRK1-0325-PFV	x					
8000-064	Compressor CRK1-0325-TF5		x				
8000-065	Compressor CRK1-0325-TFD					x	
8000-027	Compressor AG122ET			x			
8000-031	Compressor AG122RT				x		
8000-048	Compressor AG122UT						x
5051-028	Condenser Coil	x	x	x	x	x	x
8401-007	Contactors 1P25A	x					
8401-002	Contactors 3P25A		x		x	x	x
8401-006	Contactors - Heat 24V	x	x	x	x		
8401-016	Contactors 1P35A			x			
5060-025	Evaporator Coil	x	x	x	x	x	x
5151-021	Fan Blade B2430-4 ccw	x	x			x	
5151-022	Fan Blade B2425-4 ccw			x	x		x
8614-017	Fuse Block	x		x			
8614-013	Fuse Block	x		x			
8614-022	Fuse 60A	x		x			
8614-006	Fuse 30A	x		x			
8614-007	Fuse 60A	x		x			
8604-048	Heat Strip 9Kw		x			x	
8604-046	Heat Strip 12Kw		x			x	
8604-047	Heat Strip 15Kw	x	x	x	x		
8604-044	Heat Strip 10Kw	x		x			
8604-050	Heat Strip 9Kw					x	x
8604-051	Heat Strip 12Kw					x	x
8604-052	Heat Strip 15Kw					x	x
8402-012	Limit Switch 130°	x	x	x	x	x	x
8106-015	Motor - Blower 1/2 hp	x	x	x	x	x	x
8105-021	Motor - Fan 1/3 hp	x	x			x	
8106-016	Motor - Fan 1/2 hp			x	x		x
5451-011	Motor Mtg. Parts	x	x	x	x	x	x
8200-004	Motor Mount - Fan	x	x	x	x	x	x
8200-003	Motor Mount - Blower	x	x	x	x	x	x
8201-009	Relay - Blower	x	x	x	x		
8201-008	Relay - Blower					x	x
5210-005	Strainer	x	x	x	x	x	x
8607-006	Terminal Board 24V	x	x	x	x	x	x
8607-001	Terminal Block 230V	x		x		x	x
8607-002	Terminal Block 230V		x		x	x	x
8402-025	Thermal Cut-off	x	x	x	x	x	x
8407-015	Transformer 55VA	x	x	x	x	x	x
8407-004	Transformer-Stepdown					x	x

\*Please order by model number.

Minimum Net Billing \$15.00. Supersedes all previous lists. Subject to change without notice. F.O.B. Bryan, Ohio.

PARTS LIST

SINGLE PACKAGE AIR CONDITIONERS

Effective 1/1/80  
Supersedes 1/1/79

PART NO.	DESCRIPTION	MU32A	MU36B	MU42B	MU48	MU60
*	Blower Housing 10-8	x	x	x		
*	Blower Housing 10-10				x	x
5152-013	Blower Wheel DD10-8A	x	x	x		
5152-016	Blower Wheel DD10-10A				x	x
8552-020	Capacitor 35/370V	x				
8552-002	Capacitor 5/370V	x	x	x	x	x
8552-012	Capacitor 35/440V		x			x
8552-019	Capacitor 5/440V	x	x	x		
8552-014	Capacitor 25/20-440V				x	
8552-021	Capacitor 20/440V					x
8552-005	Capacitor 10/370V				x	x
8552-009	Capacitor 25/15-440V			x		
5811-013	Capillary Tube	(3)	(3)			
5811-009	Capillary Tube			(3)		
5811-014	Capillary Tube				(3)	
5811-024	Capillary Tube					(2)
8000-024	Compressor H20A323AB	x				
8000-029	Compressor H20A403AB		x			
8000-013	Compressor YRC4-0350			x		
8000-016	Compressor CL157ET				x	
8000-020	Compressor CL168YT					x
5051-001	Condenser Coil	x	x			
5051-016	Condenser Coil			x		
5051-009	Condenser Coil				x	x
8401-007	Contacto - Comp. 25A	x				
8401-003	Contacto - Comp. 30A		x	x		
8401-001	Contacto - Comp. 40A				x	x
8401-006	Contacto - Heater 20A	x	x	x	x	x
5060-015	Evaporator Coil	x	x			
5060-008	Evaporator Coil			x	x	
5060-014	Evaporator Coil					x
5151-001	Fan Blade TF1839	x	x	x		
5151-018	Fan Blade TE2028				x	x
7051-008	Fan Guard	x	x	x	x	x
8614-007	Fuse - Heater 60A	x	x	x	x	x
8614-022	Fuse - Comp. 60A	x	x	x	x	x
8614-006	Fuse - Heater 30A	x	x	x	x	x
8614-017	Fuse Block 15Kw	x	x	x	x	x
8614-013	Fuse Block 20Kw	x	x	x	x	x

\*Please order by model number.

PARTS LIST  
SINGLE PACKAGE AIR CONDITIONERS

Effective 1/1/80  
Supersedes 1/1/79

PART NO.	DESCRIPTION	MU32A	MU36B	MU42B	MU48	MU60
8604-023	Heat Strip 5Kw	x	x	x	x	x
8604-024	Heat Strip 10Kw	x	x	x	x	x
8604-025	Heat Strip 15Kw	x	x	x	x	x
8402-011	Limit Switch 140° 1.5	x	x	x	x	x
8105-010	Motor - Blower 1/3 hp	x	x	x		
8108-001	Motor - Blower 1 hp				x	x
8103-007	Motor - Fan 1/5 hp	x	x	x		
8106-009	Motor - Fan 1/2 hp				x	x
8200-003	Motor Mount - Blower	x	x	x	x	x
8200-019	Motor Mount - Fan	x	x	x		
8200-005	Motor Mount - Fan				x	x
5451-011	Motor Mtg. Parts - Blower	x	x	x	x	x
5451-009	Motor Mtg. Parts - Fan	x	x	x	x	x
5153-022	Rain Shield	x	x	x		
5153-010	Rain Shield				x	x
8201-014	Relay - Blower	x	x	x	x	x
5210-003	Strainer	x	x	x	x	
5210-005	Strainer					x
8551-001	Start Capacitor 135-155				x	x
8201-020	Start Relay				x	x
8607-001	Terminal Block 230V	x	x	x	x	x
8607-005	Terminal Board 24V				x	x
8402-030	Thermal Cut-off	x	x	x		
8402-025	Thermal Cut-off				x	x
8407-007	Transformer	x	x	x		
8407-015	Transformer				x	x
8607-006	Terminal Block	x	x	x		

Minimum Net Billing \$15.00. Supersedes all previous lists.  
Subject to change without notice. F.O.B. Bryan, Ohio.

## PARTS LIST

## SINGLE PACKAGE AIR CONDITIONERS

Effective 1/1/80  
Supersedes 1/1/79

PART NO.	DESCRIPTION	RPM18	RPM24-1	RPM30
5152-039	Blower Housing SI10-6AT	x	x	x
5152-007	Blower Wheel 10 x 4	x		
5152-017	Blower Wheel 10 x 4-1/2		x	
5152-009	Blower Wheel 10 x 5-1/2			x
8552-015	Capacitor 25/370V	x		
8552-007	Capacitor 20/15 - 370V		x	x
5811-002	Capillary Tube - Cool	(3)		
5811-013	Capillary Tube - Cool		(3)	
5811-010	Capillary Tube - Cool			(3)
8000-001	Compressor AB111FT	x		
8000-002	Compressor AB114FT		x	
8000-023	Compressor AH152HT			x
5051-011	Condenser Coil	x		
5051-017	Condenser Coil		x	x
8401-007	Contactator 25A	x	x	x
8401-006	Contactator 24V 20A	x	x	x
5060-013	Evaporator Coil	x		
5060-018	Evaporator Coil		x	x
5151-001	Fan Blade TF1839	x	x	x
7003-007	Filter 17-1/2 x 17-1/2 x 1/2	x	x	x
8604-023	Heat Strip 5Kw	x	x	x
8604-024	Heat Strip 10Kw	x	x	x
8402-024	Limit Switch L180-4	x	x	x
8106-005	Motor 1/2 hp	x	x	x
8201-009	Relay - Blower	x	x	x
5210-003	Strainer	x	x	x
8607-005	Terminal Board 24V	x	x	x
8607-001	Terminal Block 230V	x	x	x
8402-019	Thermal Cut-off	x	x	x
8407-007	Transformer	x	x	x

Minimum Net Billing \$15.00. Supersedes all previous lists.  
Subject to change without notice. F.O.B. Bryan, Ohio.

PARTS LIST  
SPLIT SYSTEM HEAT PUMPS

Effective 1/1/80  
Supersedes 1/1/79

PART NO.	DESCRIPTION	18HPQ1	24HPQ1	30HPQ3	36HPQ3	36HPQ3-3	42HPQ	42HPQ-3	48HPQ2	48HPQ2-3	60HPQ3	60HPQ3-3	36HPQ3-3 460V	48HPQ2-3 460V	60HPQ3-3 460V
5202-001	Accumulator	x	x												
5202-003	Accumulator			x											
5202-004	Accumulator				x	x							x		
5202-007	Accumulator						x	x	x	x				x	
5202-005	Accumulator										x	x			x
8552-002	Capacitor 5/370V	x	x	x	x	x							x		
8552-007	Capacitor 20/15-370V	x	x	x											
8552-012	Capacitor 35/440V				x										
8552-020	Capacitor 35/370V						x								
8552-022	Capacitor 20/370V						x								
8552-017	Capacitor 45/440V							x			x				
8552-005	Capacitor 10/370V						x	x	x	x	x	x		x	x
5811-031	Cap. Tube - Heat	x													
5811-014	Cap. Tube - Heat		x												
5811-027	Cap. Tube - Heat			x	x	x							x		
5811-018	Cap. Tube - Heat						(2)	(2)	(2)	(2)				(2)	
5811-019	Cap. Tube - Heat										(2)	(2)			(2)
5651-006	Check Valve	x	x	x	x	x	x	x	x	x	x	x	x	x	x
8000-004	Compressor AH121HT	x													
8000-005	Compressor AH141FT		x												
8000-006	Compressor AH152GT			x											
8000-008	Compressor AH301FT				x										
8000-009	Compressor AH302RT					x									
8000-045	Compressor H2EA413AB						x								
8000-046	Compressor H2EA413DB							x							
8000-026	Compressor AG5546E								x						
8000-030	Compressor AG111RT									x					
8000-047	Compressor AG111UT													x	
8000-010	Compressor AH302TT												x		
8000-027	Compressor AG122ET										x				
8000-031	Compressor AG122RT											x			
8000-048	Compressor AG122UT														x
5051-004	Condenser Coil	x													
5051-008	Condenser Coil		x												
5051-003	Condenser Coil			x	x	x							x		
5051-021	Condenser Coil						x	x	x	x				x	
5051-022	Condenser Coil										x	x			x
8401-007	Contact - Comp. 25A	x	x	x											
8401-003	Contact - Comp. 30A				x		x		x						
8401-002	Contact - Comp. 25A					x		x		x			x	x	x
8401-016	Contact - Comp. 35A										x				
8605-001	Crankcase Heater					x		x							
8605-002	Crankcase Heater												x		
8408-004	Defrost Mounting Plate	x	x	x	x	x	x	x	x	x	x	x	x	x	x
8408-002	Defrost Thermostat	x	x	x	x	x	x	x	x	x	x	x	x	x	x
5151-001	Fan Blade TF1839	x	x												
5151-007	Fan Blade TP2029			x	x	x							x		
5151-017	Fan Blade FA2430-4B						x	x	x	x	x	x		x	x

PARTS LIST  
SPLIT SYSTEM HEAT PUMPS

Effective 1/1/77  
Supersedes 1/1/77

PART NO.	DESCRIPTION	18HPQ1	24HPQ1	30HPQ3	36HPQ3	36HPQ3-3	42HPQ	42HPQ-3	48HPQ2	48HPQ2-3	60HPQ3	60HPQ3-3	36HPQ3-3 460V	48HPQ2-3 460V	60HPQ3-3 460V
8406-010	High Pressure Switch	x	x	x	x	x							x		
8406-011	High Pressure Switch						x	x	x	x	x	x		x	x
8103-008	Motor - Fan 1/5	x	x												
8103-009	Motor - Fan 1/5			x	x	x							x		
8105-005	Motor - Fan 1/3						x	x	x	x	x	x		x	x
8200-001	Motor Mount - Fan	x	x	x	x	x							x		
8200-004	Motor Mount - Fan						x	x	x	x	x	x		x	x
8201-008	Relay - Motor & Control													x	x
8201-013	Relay - Changeover	x	x	x	x	x							x		
8201-018	Relay - Defrost	x	x	x	x	x							x		
8201-023	Relay - Defrost						x	x	x	x	x	x		x	x
8201-015	Relay - Emer. Heat	x	x	x	x	x							x		
8201-024	Relay - Comp. Fault						x		x		x				
5650-004	Reversing Valve	x	x												
5650-005	Reversing Valve			x											
5650-006	Reversing Valve				x	x	x	x					x		
5650-007	Reversing Valve								x	x	x	x		x	x
5650-002	Solenoid Coil	x	x	x	x	x							x		
5210-002	Strainer	x	x	x	x	x							x		
5210-005	Strainer						x	x	x	x	x	x		x	
8607-006	Terminal Board 24V	x	x	x	x	x							x		
8607-011	Terminal Board						x	x	x	x	x	x		x	x
8612-008	Timer	x	x	x	x	x							x		
8612-010	Timer						x	x	x	x	x	x		x	x
8407-003	Transformer-Stepdown												x	x	x
5650-008	Solenoid Coil						x	x	x	x	x	x		x	x

Minimum Net Billing \$15.00. Supersedes all previous lists.  
Subject to change without notice. F.O.B. Bryan, Ohio.

PARTS LIST  
SINGLE PACKAGE HEAT PUMPS

Effective 1/1/80  
Supersedes 1/1/79

PART NO.	DESCRIPTION	18WH2	24WH2
5202-001	Accumulator	x	
5202-003	Accumulator		x
5152-030	Blower Housing 9-7	x	x
5152-028	Blower Wheel 9-7	x	x
5152-029	Blower Wheel 9-7	x	x
8552-027	Capacitor 25/370V	x	x
8552-002	Capacitor 5/370V	x	x
5811-017	Capillary Tube - Cool	x	
5811-018	Capillary Tube - Heat	x	
5811-021	Capillary Tube - Cool & Heat		(2)
5651-006	Check Valve	x	x
8000-061	Compressor RES3-0175-PFV-270	x	
8000-062	Compressor AB224FT-014-A4		x
5051-008	Condenser Coil	x	
5051-026	Condenser Coil		x
8401-007	Contacto-Compressor 25A	x	x
8401-006	Contacto - Heater 2P18	x	x
8408-004	Defrost Mounting Plate	x	x
8408-002	Defrost Thermostat	x	x
5060-005	Evaporator Coil	x	
5060-024	Evaporator Coil		x
5151-024	Fan Blade A-1831-5 ccw	x	x
7004-006	Filter 14x25	x	x
8604-041	Heat Strip 4Kw	x	x
8604-043	Heat Strip 8Kw	x	x
8406-011	High Pressure Switch	x	x
8402-029	Limit Switch 160°	x	x
8102-008	Motor - Blower 1/6 hp	x	x
8103-009	Motor - Fan 1/5 hp	x	x
8201-009	Relay - Blower	x	x
8201-023	Relay - Defrost	x	x
8201-024	Relay - Compressor Fault	x	x
8201-013	Relay - Emergency Heat	x	x
5650-004	Reversing Valve	x	
5650-009	Reversing Valve		x
5650-008	Solenoid Coil	x	x
5210-002	Strainer	(2)	(2)
8607-010	Terminal Board	x	x
8607-001	Terminal Block 230V	x	x
8607-003	Terminal Block 230V	x	x
8402-030	Thermal Cut-off	x	x
8612-010	Timer	x	x
8407-015	Transformer	x	x
8552-004	Capacitor 7.5/370V	x	x

Minimum Net Billing \$15.00. Supersedes all previous lists.  
Subject to change without notice. F.O.B. Bryan, Ohio.



PARTS LIST  
SINGLE PACKAGE HEAT PUMPS

Effective 1/1/81  
Supersedes 1/1/77

PART NO.	DESCRIPTION	30WH1	36WH2	36WH2-3	36WH2-3 460V
5202-003	Accumulator	x			
5202-004	Accumulator		x	x	x
5152-030	Blower Housing 9-7	x	x	x	x
5152-028	Blower Wheel 9-7	x	x	x	x
5152-029	Blower Wheel 9-7	x	x	x	x
8552-020	Capacitor 35/370V	x			
8552-022	Capacitor 20/370V	x			
8552-012	Capacitor 35/440V		x		
8552-002	Capacitor 5/370V	x	x	x	x
5811-014	Cap Tube - Cool 37-1/2 x .070	(2)			
5811-020	Cap Tube - Heat 26 x .080	x			
5811-033	Cap Tube - Cool 32 x .070		(2)	(2)	(2)
5811-019	Cap Tube - Heat 18-1/2 x .080		x	x	x
5651-006	Check Valve	x	x	x	x
8000-042	Compressor H2EA293AB	x			
8000-058	Compressor CRJ1-0300-PFV-270		x		
8000-059	Compressor CRJ1-0300-TF5-270			x	
8000-060	Compressor CRJ1-0300-TFD-270				x
5051-003	Condenser Coil	x	x	x	x
8401-007	Contactator - Comp. 1P25A	x	x		
8401-002	Contactator - Comp. 3P25A			x	x
8401-006	Contactator - Heater 2P20	x	x	x	
8408-004	Defrost Mounting Plate	x	x	x	x
8408-002	Defrost Thermostat	x	x	x	x
5060-023	Evaporator Coil	x	x	x	x
5151-025	Fan Blade F10H08-2027 cw	x	x	x	x
7004-008	Filter 15 x 30-5/8 x 1	x	x	x	x
8614-013	Fuse Block 15Kw	x	x		
8614-022	Fuse 60A	x	x		
8614-007	Fuse 60A	x	x		
8604-042	Heat Strip 5Kw	x	x		
8604-044	Heat Strip 10Kw	x	x		
8604-047	Heat Strip 15Kw	x	x		
8604-049	Heat Strip 6Kw			x	
8604-048	Heat Strip 9Kw			x	
8604-050	Heat Strip 9Kw				x
8604-060	Heat Strip 6Kw				x
8406-010	High Pressure Switch	x	x	x	x
8402-031	Limit Switch 155°	x	x	x	x
8552-003	Capacitor 6/370V	x	x	x	x
8552-001	Capacitor 4/370V		x	x	
8201-033	Relay - Defrost				x
					x

PARTS LIST  
SINGLE PACKAGE HEAT PUMPS

Effective 1/1/80  
Supersedes 1/1/79

PART NC.	DESCRIPTION	48WH1	48WH1-3	48WH1-3 460'
5202-007	Accumulator	x	x	x
5152-026	Blower Housing 10-8	x	x	x
5152-011	Blower Wheel DD10-8A	x	x	x
5152-012	Blower Wheel DD10-8A	x	x	x
8552-017	Capacitor 45/440V	x		
8552-005	Capacitor 10/370V	x	x	x
5811-023	Capillary Tube - Heat	x	x	x
5811-008	Capillary Tube - Cool	(3)	(3)	(3)
5651-006	Check Valve	x	x	x
8000-026	Compressor AG111ET	x		
8000-030	Compressor AG111RT		x	
8000-047	Compressor AG111UT			x
5051-021	Condenser Coil	x	x	x
8401-003	Contactator - Comp. 30A	x		
8401-002	Contactator - Comp. 25A		x	x
8401-006	Contactator - Heater 20A	x	x	
8408-004	Defrost Mounting Plate	x	x	x
8408-002	Defrost Thermostat	x	x	x
5060-021	Evaporator Coil	x	x	x
5151-021	Fan Blade F15A24-2430	x	x	x
7004-010	Filter 16x20	x	x	x
8614-007	Fuse - Heater 60A	x		
8614-022	Fuse - Compressor 60A	x		
8614-006	Fuse - 30A	x		
8614-014	Fuse Block 25Kw	x		
8614-019	Fuse Block 30Kw	x		
8604-044	Heat Strip 10Kw	x		
8604-048	Heat Strip 9Kw		x	
8604-046	Heat Strip 12Kw		x	
8604-047	Heat Strip 15Kw	x	x	
8604-050	Heat Strip 9Kw			x
8604-051	Heat Strip 12Kw			x
8604-052	Heat Strip 15Kw			x
8406-010	High Pressure Switch	x	x	x
8402-029	Limit Switch L160-2.5	x	x	x
8106-005	Motor - Blower 1/2 hp	x	x	x
8105-005	Motor - Fan 1/3 hp	x	x	x
8200-004	Motor Mount - Fan	x	x	x
8201-008	Relay - Blower	x	x	x
8201-013	Relay - Changeover	x	x	x
8201-018	Relay - Defrost	x	x	x
8201-015	Relay - Emergency Heat	x	x	x
5650-006	Reversing Valve	x	x	x
5650-002	Solenoid Coil	x	x	x
5210-002	Strainer	x	x	x
5210-003	Strainer	x	x	x
8607-006	Terminal Board 24V	x	x	x
8607-001	Terminal Block 230V	x		x
8607-002	Terminal Block 230V		x	x
8607-003	Terminal Block 230V	x		
8402-032	Thermal Cut-off	x	x	x
8612-008	Timer	x	x	x
8407-015	Transformer	x	x	x
8407-004	Transformer - Stepdown			x

Minimum Net Billing \$15.00. Supersedes all previous lists.  
Subject to change without notice. F.O.B. Bryan, Ohio

PARTS LIST  
SINGLE PACKAGE HEAT PUMPS

Effective 1/1/80  
Supersedes 1/1/79

PART NO.	DESCRIPTION	30WH1	36WH2	36WH2-3	36WH2-3 460V
8105-019	Motor - Blower 1/3 hp	x	x	x	
8105-015	Motor - Blower 1/3 hp				x
8105-020	Motor - Fan 1/3 hp	x	x	x	
8105-016	Motor - Fan 1/3 hp				x
8200-001	Motor Mount - Fan	x	x	x	x
8201-009	Relay - Blower	x	x	x	
8201-032	Relay - Blower				x
8201-031	Relay - Compressor Fault	x			
8201-023	Relay - Defrost	x	x	x	
8201-013	Relay - Emergency Heat	x	x	x	x
5650-005	Reversing Valve	x			
5650-006	Reversing Valve		x	x	x
5550-008	Solenoid Coil	x	x	x	x
5210-004	Strainer	x	x	x	x
5210-002	Strainer	x	x	x	x
8607-010	Terminal Board 24V	x	x	x	x
8607-001	Terminal Block 230V	x	x		x
8607-003	Terminal Block 230V	x	x		
8607-002	Terminal Block 230V			x	x
8402-032	Thermal Cut-off	x	x	x	x
8612-010	Timer	x	x	x	x
8407-015	Transformer	x	x	x	x
8407-028	Transformer - Stepdown				x
8201-024	Relay - Compressor Fault		x		

Minimum Net Billing \$15.00. Supersedes all previous lists.  
Subject to change without notice. F.O.B. Bryan, Ohio

PARTS LIST  
SINGLE PACKAGE HEAT PUMPS

Effective 1/1/80  
Supersedes 1/1/79

PART NO.	DESCRIPTION	PH24	PH30
5202-001	Accumulator	x	
5202-006	Accumulator		x
5152-020	Blower Housing SI110-6AT	x	x
5152-009	Blower Wheel 10 x 5-1/2	x	x
8552-007	Capacitor 20/15 - 370V	x	x
8552-002	Capacitor 5/370V	x	x
5811-021	Cap Tube - Cool	x	
5811-019	Cap Tube - Heat	x	
5811-027	Cap Tube - Cool		x
5811-023	Cap Tube - Heat		x
5651-006	Check Valve	x	x
5051-008	Condenser Coil	x	x
8000-005	Compressor AH141FT	x	
8000-006	Compressor AH152GT		x
8401-006	Contactora - Compressor 20A	x	x
8401-006	Contactora - Heater 20A	x	x
8408-004	Defrost Mounting Plate	x	x
8408-006	Defrost Thermostat	x	x
5060-005	Evaporator Coil	x	x
5151-009	Fan Blade FF1827-4	x	x
8604-042	Heat Strip 5Kw	x	x
8604-044	Heat Strip 10Kw	x	x
8406-010	High Pressure Switch	x	x
8402-015	Limit Switch L130-2.0	x	x
8106-005	Motor - Blower and Fan 1/2 hp	x	x
8201-008	Relay - Blower	x	x
8201-013	Relay - Changeover	x	x
8201-018	Relay - Defrost	x	x
8201-015	Relay - Emergency Heat	x	x
8201-011	Relay - Interlock	x	x
5650-004	Reversing Valve	x	
5650-005	Reversing Valve		x
5650-002	Solenoid Coil	x	x
5210-002	Strainer	x	x
8607-006	Terminal Board 24V	x	x
8607-001	Terminal Block 230V	x	x
8607-003	Terminal Block 230V	x	x
8402-026	Thermal Cut-off	x	x
8612-010	Timer	x	x
8407-015	Transformer	x	x

Minimum Net Billing \$15.00. Supersedes all previous lists.  
Subject to change without notice. F.O.B. Bryan, Ohio.

PARTS LIST  
SINGLE PACKAGE HEAT PUMPS

Effective 1/1/81  
Supersedes 1/1/79

PART NO.	DESCRIPTION	PH31-1	PH36-2	PH36-2 3-Ph	PH36-2 460V 3-Ph
5202-003	Accumulator	x			
5202-004	Accumulator		x	x	x
*	Blower Housing 10-8	x	x	x	x
5152-013	Blower Wheel DD10-8A	x	x	x	x
8552-020	Capacitor - Comp. 35/370V	x			
8552-022	Capacitor - Comp. 20/370V	x			
8552-002	Capacitor - Fan & Blower 5/370V	x	x	x	x
8552-024	Capacitor - Comp. 40/370V		x		
8552-015	Capacitor - Comp. 25/370V		x		
5811-014	Capillary Tube - Cool	(2)			
5811-020	Capillary Tube - Heat	x			
5811-033	Capillary Tube - Cool		(2)	(2)	(2)
5811-019	Capillary Tube - Heat		x	x	x
5651-006	Check Valve	x	x	x	x
5051-003	Condenser Coil	x	x	x	x
8000-042	Compressor H2EA293AB	x			
8000-051	Compressor H2EA363AB		x		
8000-059	Compressor CRJ1-0300-TF5-270			x	
8000-060	Compressor CRJ1-0300-TFD-270				x
8401-007	Contactator - Compressor 1P25A	x	x		
8401-006	Contactator - Heater 2P20	x	x	x	
8401-002	Contactator - Compressor			x	x
8401-010	Contactator - Heater 2P30			x	
8408-004	Defrost Mounting Plate	x	x	x	x
8408-002	Defrost Thermostat	x	x	x	x
5060-023	Evaporator Coil	x	x	x	x
5151-004	Fan Blade TP2026 cw	x	x	x	
5151-025	Fan Blade L10H08-2027 cw				x
8614-013	Fuse Block 15Kw	x	x		
8614-022	Fuse 60A (Comp.)	x	x		
8614-007	Fuse 60A (Heater)	x	x		
8604-042	Heat Strip 5Kw	x	x		
8604-044	Heat Strip 10Kw	x	x		
8604-047	Heat Strip 15Kw	x	x	x	
8604-048	Heat Strip 9Kw			x	
8604-046	Heat Strip 12Kw			x	
8604-050	Heat Strip 9Kw				x
8604-051	Heat Strip 12Kw				x
8604-052	Heat Strip 15Kw				x
8604-010	Hi Pressure Switch	x	x	x	x
8402-012	Limit Switch 130°	x	x	x	x
8105-020	Motor - Blower 1/3 hp ccw	x	x	x	
8105-018	Motor - Blower 1/3 hp ccw				x
8103-009	Motor - Fan 1/5 hp	x	x	x	
8105-016	Motor - Fan 1/3 hp				x

\*Please order by model number.

**PARTS LIST**  
**SINGLE PACKAGE HEAT PUMPS**

Effective 1/1/80  
Supersedes 1/1/79

PART NO.	DESCRIPTION	PH31-1	PH36-2	PH36-2 3-Ph	PH36-2 460V 3-Ph
8200-003	Motor Mount - Blower	x	x	x	x
8200-001	Motor Mount - Fan	x	x	x	x
5451-011	Motor Mounting Parts	x	x	x	x
8201-009	Relay - Blower	x	x	x	
8201-032	Relay - Blower				x
8201-023	Relay - Defrost	x	x	x	
8201-033	Relay - Defrost				x
5650-005	Reversing Valve	x			
5650-006	Reversing Valve		x	x	x
5650-008	Solenoid Coil	x	x	x	x
5210-004	Strainer	x	x	x	x
5210-002	Strainer	x	x	x	x
8607-010	Terminal Board 24V	x	x	x	x
8607-001	Terminal Block 230V	x	x		
8607-003	Terminal Block 230V	x	x		
8607-002	Terminal Block 230V			x	x
8402-026	Thermal Cut-off	x	x	x	x
8612-010	Timer	x	x	x	x
8407-015	Transformer	x	x	x	x
8407-028	Transformer - Stepdown				x
8201-031	Relay - Compressor Fault	x	x		
8201-013	Relay - Emergency Heat	x	x	x	x

Minimum Net Billing \$15.00. Supersedes all previous lists.  
Subject to change without notice. F.O.B. Bryan, Ohio

PARTS LIST  
SINGLE PACKAGE HEAT PUMPS

Effective 1/1  
Supersedes 1/1/

PART NO.	DESCRIPTION	PH48-1	PH48-1 3-Ph	PH60-1	PH60-1 3-Ph	PH48-1 460V 3-Ph	PH60-1 460V 3-Ph
5202-007	Accumulator	x	x	x	x	x	x
*	Blower Housing 10-10	x	x	x	x	x	x
5152-015	Blower Wheel DD10-10A	x	x	x	x	x	x
8552-017	Capacitor 45/440V	x		x			
8552-005	Capacitor 10/370V	x	x	x	x	x	x
8552-004	Capacitor 7½/370V			x	x		x
8552-026	Capacitor 15/370V	x	x			x	
5811-018	Capillary Tube - Heat			(2)	(2)		(2)
5811-025	Capillary Tube - Cool			(2)	(2)		(2)
5811-008	Capillary Tube - Cool	(3)	(3)			(3)	
5811-032	Capillary Tube - Heat	x	x			x	
5651-006	Check Valve	x	x	x	x	x	x
5051-021	Condenser Coil	x	x			x	
5051-022	Condenser Coil			x	x		x
8000-026	Compressor AG111ET	x					
8000-030	Compressor AG111RT		x				
8000-027	Compressor AG122ET			x			
8000-031	Compressor AG122RT				x		
8000-047	Compressor AG111UT					x	
8000-048	Compressor AG122UT						
83494	Compressor Overload	x					
83493	Compressor Overload		x				
83672	Compressor Overload			x			
83684	Compressor Overload				x		
8401-003	Contactator - Comp. 30A	x					
8401-002	Contactator - Comp. 25A		x		x	x	x
8401-016	Contactator - Comp. 35A			x			
8401-006	Contactator - Heater 20A	x	x	x	x		
8408-004	Defrost Mounting Plate	x	x	x	x	x	x
8408-002	Defrost Thermostat	x	x	x	x	x	x
5060-001	Evaporator Coil	x	x			x	
5060-011	Evaporator Coil			x	x		x
5151-021	Fan Blade B2430-4	x	x			x	
5151-022	Fan Blade B2425-4			x	x		x
8614-022	Fuse - Comp. 60A	x		x			
8614-007	Fuse - Heater 60A	x		x			
8614-006	Fuse - Heater 30A	x		x			
8614-014	Fuse Block 15Kw	x		x			
8614-019	Fuse Block 20Kw	x		x			
8604-044	Heat Strip 10Kw	x		x			
8604-047	Heat Strip 15Kw	x	x	x	x		
8604-050	Heat Strip 9Kw						
8604-052	Heat Strip 15Kw					x	x
8604-046	Heat Strip 12Kw		x		x		
8604-048	Heat Strip 9Kw		x		x		

\*Please order by model number.

PARTS LIST  
SINGLE PACKAGE HEAT PUMPS

Effective 1/1/80  
Supersedes 1/1/79

PART NO.	DESCRIPTION	PH48-1	PH48-1 3-Ph	PH60-1	PH60-1 3-Ph	PH48-1 460V 3-Ph	PH60-1 460V 3-Ph
8406-010	High Pressure Switch	X	X	X	X	X	X
8402-012	Limit Switch 130-115°	X	X	X	X	X	X
8106-015	Motor - Blower 1/2 hp	X	X	X	X	X	X
8105-021	Motor - Fan 1/3 hp	X	X			X	
8106-016	Motor - Fan 1/2 hp			X	X		X
8200-003	Motor Mount - Blower	X	X	X	X	X	X
8200-004	Motor Mount - Fan	X	X	X	X	X	X
5451-011	Motor Mounting Parts	X	X	X	X	X	X
8201-008	Relay - Blower	X	X	X	X	X	X
8201-013	Relay - Changeover	X	X	X	X	X	X
8201-018	Relay - Defrost	X	X	X	X	X	X
8201-015	Relay - Emergency Heat	X	X	X	X	X	X
5650-006	Reversing Valve	X	X	X	X	X	X
5650-002	Solenoid Coil	X	X	X	X	X	X
5210-002	Strainer	X	X			X	
5210-003	Strainer	X	X			X	
5210-005	Strainer			X	X		X
8607-006	Terminal Board 24V	X	X	X	X	X	X
8607-001	Terminal Block 230V	X		X		X	X
8607-002	Terminal Block 230V		X		X	X	X
8607-003	Terminal Block 230V	X		X			
8402-025	Thermal Cut-off	X	X	X	X	X	X
8612-008	Timer	X	X	X	X	X	X
8407-015	Transformer	X	X	X	X	X	X
8407-004	Transformer - Stepdown					X	X

Minimum Net Billing \$15.00. Supersedes all previous lists.  
Subject to change without notice. F.O.B. Bryan, Ohio.



PARTS LIST  
SINGLE PACKAGE HEAT PUMPS

Effective 1/1/80  
Supersedes 1/1/79

PART NO.	DESCRIPTION	MH30	MH36
5202-003	Accumulator	x	
5202-004	Accumulator		x
*	Blower Housing 10-8	x	x
5152-013	Blower Wheel DD10-8A	x	x
8552-020	Capacitor 35/370V	x	x
8552-022	Capacitor 20/370V	x	x
8552-019	Capacitor 5/440V	x	x
8552-002	Capacitor 5/370V	x	x
5811-010	Capillary Tube - Cool	(3)	(3)
5811-021	Capillary Tube - Heat	x	x
5651-006	Check Valve	(2)	(2)
5051-003	Condenser Coil	x	x
8000-042	Compressor H2EA293AB	x	
8000-045	Compressor H2EA413AB		x
8401-007	Contactors 1P25A	x	
8401-003	Contactors 1P30A		x
8401-006	Contactors 2P20	x	x
8408-004	Defrost Mounting Plate	x	x
8408-002	Defrost Thermostat	x	x
5060-015	Evaporator Coil	x	x
5151-001	Fan Blade TF1839 ccw	x	x
7051-008	Fan Guard	x	x
8614-006	Fuse OT30	x	x
8614-007	Fuse OT60	x	x
8614-022	Fuse TR60	x	x
8614-017	Fuse Block 10Kw	x	x
8614-018	Fuse Block 15-20Kw	x	x
8604-023	Heat Strip 5Kw	x	x
8604-024	Heat Strip 10Kw	x	x
8604-025	Heat Strip 15Kw	x	x
8406-011	Hi Pressure Switch	x	x
8402-011	Limit Switch 140°-125°	x	x
8105-010	Motor - Blower 1/3 hp	x	x
8103-007	Motor - Fan 1/5 hp	x	x
8200-003	Motor Mount - Blower	x	x
8200-019	Motor Mount - Fan	x	x
5451-011	Motor Mounting Parts	x	x
5451-009	Motor Mounting Parts (Fan)	x	x
8201-009	Relay - Blower	x	x
8201-031	Relay - Compressor Fault	x	
8201-024	Relay - Compressor Fault		x
8201-023	Relay - Defrost	x	x
8201-013	Relay - Emergency Heat	x	x
5650-005	Reversing Valve	x	
5650-006	Reversing Valve		x
5650-008	Solenoid Coil	x	x
5210-003	Strainer	x	x
5210-002	Strainer	x	x
8607-001	Terminal Block	x	x
8607-010	Terminal Board	x	x
8402-030	Thermal Cut-off	x	x
8612-010	Timer	x	x
8407-015	Transformer 55VA	x	x
5153-022	Rain Shield	x	x

\*Please order by model number. Minimum Net Billing \$15.00. Supersedes all previous lists. Subject to change without notice. F.O.B. Bryan, Ohio.

PARTS LIST  
SINGLE PACKAGE HEAT PUMPS

Effective 1/1/80  
Supersedes 1/1/79

PART NO.	DESCRIPTION	RPMH30	RPMH30-3	RPMH36	RPMH36-3	RPMH30-3 460V	RPMH36-3 460V
5202-003	Accumulator	x	x	x			
5202-004	Accumulator				x	x	x
*	Blower Housing 10-8	x	x	x	x	x	x
5152-010	Blower Wheel DD10-7A	x	x	x	x	x	x
8552-024	Capacitor 40/370V	x		x			
8552-019	Capacitor 5/440V	x	x	x	x	x	x
8552-002	Capacitor 5/370V	x	x	x	x	x	x
5811-033	Capillary Tube - Cool	(2)	(2)	(2)	(2)	(2)	(2)
8201-033	Relay - Defrost					x	x
5811-026	Capillary Tube - Heat	x	x	x	x	x	x
8000-052	Compressor CRG1-0250-PFV-270	x					
8000-053	Compressor CRG1-0250-TF5-270		x				
8000-054	Compressor CRG1-0250-TFD-270					x	
8000-055	Compressor CRH1-0275-PFV-270			x			
8000-056	Compressor CRH1-0275-TF5-270				x		
8000-057	Compressor CRH1-0275-TFD-270						x
8401-007	Contactator 1P25A	x		x			
8401-002	Contactator 3P25A		x		x	x	x
8401-006	Contactator 2P20	x	x	x	x		
8408-004	Defrost Mounting Plate	x	x	x	x	x	x
8408-002	Defrost Thermostat	x	x	x	x	x	x
5060-022	Evaporator Coil	x	x	x	x	x	x
5151-024	Fan Blade A-1831-5	x	x	x	x	x	x
7051-014	Fan Guard	x	x	x	x	x	x
8614-006	Fuse OT30	x		x			
8614-007	Fuse OT60	x		x			
8614-022	Fuse TR60	x		x			
8614-017	Fuse Block	x		x			
8614-018	Fuse Block	x		x			
8604-023	Heat Strip 5Kw	x		x			
8604-024	Heat Strip 10Kw	x		x			
8604-025	Heat Strip 15Kw	x		x			
8604-035	Heat Strip 9Kw		x		x		
8604-036	Heat Strip 12Kw		x		x		
8604-032	Heat Strip 9Kw					x	x
8604-033	Heat Strip 12Kw					x	x
8406-011	Hi Pressure Switch	x	x	x	x	x	x
8402-020	Limit Switch 140°-125°	x	x	x	x	x	x
8105-010	Blower Motor 1/3 hp	x	x	x	x		
8103-007	Fan Motor 1/5 hp	x	x	x	x		
8200-003	Motor Mount - Blower	x	x	x	x	x	x
8200-022	Motor Mount - Fan	x	x	x	x	x	x
5451-011	Motor Mounting Parts	x	x	x	x	x	x
5451-009	Motor Mounting Parts -Fan	x	x	x	x	x	x
5651-006	Check Valve	x	x	x	x	x	x
5051-003	Condenser Coil	x	x	x	x	x	x

\*Please order by model number.

PARTS LIST  
SINGLE PACKAGE HEAT PUMPS

Effective 1/1/80  
Supersedes 1/1/79

PART NO.	DESCRIPTION	RPMH30	RPMH30-3	RPMH36	RPMH36-3	RPMH30-3 460V	RPMH36-3 460V
5153-022	Rain Shield	X	X	X	X	X	X
8201-009	Relay - Blower	X	X	X	X		
8201-032	Relay - Blower					X	X
8201-013	Relay - Emergency Heat	X	X	X	X	X	X
8201-023	Relay - Defrost	X	X	X	X		
8201-031	Relay - Compressor Fault	X		X			
5650-005	Reversing Valve	X	X			X	
5650-006	Reversing Valve			X	X		X
5650-008	Solenoid Coil	X	X	X	X	X	X
5210-004	Strainer	X	X	X	X	X	X
5210-002	Strainer	X	X	X	X	X	X
8607-010	Terminal Board	X	X	X	X	X	X
8607-001	Terminal Block	X		X			
8607-002	Terminal Block		X		X	X	X
8402-030	Thermal Cutoff	X	X	X	X		
8612-010	Timer w/7 Min.Time Safe	X	X	X	X	X	X
8407-015	Transformer	X	X	X	X	X	X
8407-028	Transformer - Stepdown					X	X
8402-034	Thermal Cutoff					X	X
8105-018	Motor - Blower 1/3 hp					X	X
8103-011	Motor - Fan 1/5					X	X
8604-064	Heat Strip 6Kw		X		X		
8604-065	Heat Strip 6Kw					X	X

Minimum Net Billing \$15.00. Supersedes all previous lists.  
Subject to change without notice. F.O.B. Bryan, Ohio

PARTS LIST  
SPLIT SYSTEM BLOWER COILS

Effective 1/1/80  
Supersedes 1/1/79

PART NO.	DESCRIPTION	B18EQ1	B24EQ1	B18EHQ	B24EHQ	B36EHQ	B48EHQ	B60EHQ
*	Blower Housing 10-4	x	x	x	x			
*	Blower Housing 10-9					x		
*	Blower Housing 10-10						x	
5152-008	Blower Wheel DD10-4A	x	x	x	x			
5152-014	Blower Wheel DD10-9A					x		
5152-015	Blower Wheel 10-10						x	
5152-044	Blower Wheel							x
8552-001	Capacitor 4/370V	x	x	x	x			
8552-002	Capacitor 5/370V					x	x	
8552-005	Capacitor 10/370V							x
5811-004	Capillary Tube	(3)						
5811-001	Capillary Tube		(3)					
5811-016	Capillary Tube			x				
5811-002	Capillary Tube				(3)			
5811-010	Capillary Tube					(3)		
5811-009	Capillary Tube						(4)	(4)
5651-006	Check Valve			x	x	x	x	x
8401-006	Contactator - Heater 20A	x	x	x	x	x	x	x
8401-010	Cont.-Heat 3-Phase						x	x
8401-001	Cont.-Heat 3-Phase						x	x
5060-003	Evaporator Coil	x						
5060-013	Evaporator Coil		x					
5060-017	Evaporator Coil			x				
5060-016	Evaporator Coil				x			
5060-012	Evaporator Coil					x		
5060-020	Evaporator Coil						x	x
7004-003	Filter 12x20	x	x	x	x			
7003-006	Filter 20x22					x		
7004-015	Filter 24x24						x	x
8614-006	Fuse - Heater 30A					x	x	x
8614-007	Fuse - Heater 60A					x	x	x
8614-035	Fuse - Heater 35A 3-Ph						x	x
8614-033	Fuse - Heater 45A 3-Ph						x	x
8614-032	Fuse - Heater 40A 3-Ph						x	x
8614-017	Fuse Block 15KW					x	x	x
8614-013	Fuse Block 20KW					x		
8614-014	Fuse Block 25Kw					x	x	x
8614-019	Fuse Block 30KW					x	x	x
8614-018	Fuse Block 20KW						x	x
8614-020	Fuse Block 30Kw 3-Ph						x	x
8614-021	Fuse Block 3-Ph							x
8604-027	Heat Strip 4Kw	x	x	x	x			
8604-023	Heat Strip 5Kw	x	x	x	x	x		x
8604-026	Heat Strip 8Kw	x	x	x	x			
8604-024	Heat Strip 10Kw	x	x	x	x	x	x	x
8604-025	Heat Strip 15Kw			x	x	x	x	x
8604-035	Heat Strip 9Kw						x	x
8604-036	Heat Strip 12Kw						x	x
5152-043	Blower Housing 12-7							x

\*Please order by model number.

PARTS LIST  
SPLIT SYSTEM BLOWER COILS

Effective 1/1/80  
Supersedes 1/1/

PART NO.	DESCRIPTION	B18EQ1	B24EQ1	B18EHQ	B24EHQ	B36EHQ	B48EHQ	B60EHQ
8402-029	Limit Switch L160-2.5			x				
8402-028	Limit Switch L150-2.5	x	x		x			
8402-022	Limit Switch L145-2.5					x		
8402-033	Limit Switch L140-2.5						x	
8402-012	Limit Switch L130-1.5							x
8102-004	Motor - Blower 1/6	x	x	x	x			
8105-010	Motor - Blower 1/3					x		
8106-013	Motor - Blower 1/2						x	
8107-003	Motor - Blower 3/4							x
8200-003	Motor Mount	x	x	x	x	x	x	
8200-021	Motor Mount							x
5451-011	Motor Mounting Parts	x	x	x	x	x	x	x
8201-009	Relay - Blower	x	x	x	x	x		
8201-014	Relay - Blower						x	x
8201-013	Relay - Emer. Heat						x	x
5210-003	Strainer	x	x		x	x		
5210-002	Strainer			x				
5210-006	Strainer						x	x
8607-006	Terminal Board 24V	x	x	x	x			
8607-005	Terminal Board 24V					x		
8607-001	Terminal Block 230V	x	x	x	x	x	x	x
8607-002	Terminal Block 3-Ph						x	x
8607-010	Terminal Block						x	x
8402-025	Thermal Cut-off					x	x	x
8402-027	Thermal Cut-off	x	x	x	x			
8407-007	Transformer	x	x					
8407-015	Transformer			x	x	x		
8407-022	Transformer						x	x

Minimum Net Billing \$15.00. Supersedes all previous lists.  
Subject to change without notice. F.O.B. Bryan, Ohio

PARTS LIST  
ELECTRIC FURNACES

Effective 1/1/80  
Supersedes 1/1/79

PART NO.	DESCRIPTION	EFC10	EFC10-B	EFC15	EFC20	EFC25	EFC30
*	Blower Housing 10-8	x					
*	Blower Housing 10-7		x	x	x		
*	Blower Housing 10-9					x	x
5152-005	Blower Wheel DD9-8A	x					
5152-010	Blower Wheel DD10-7A		x	x	x		
5152-014	Blower Wheel DD10-9A					x	x
1171-005	Cabinet Latch	(2)	(2)	(2)	(2)	(2)	(2)
8552-001	Capacitor 4/370V		x	x	x		
8552-002	Capacitor 5/370V					x	x
1171-002	Door Pull	x	x	x	x	x	x
7004-001	Filter 10x20	(2)					
7003-001	Filter 10x20 P		(2)	(2)	(2)	(2)	(2)
8614-007	Fuse 60A			(2)	(4)	(4)	(6)
8614-006	Fuse 30A			(2)		(2)	
8614-017	Fuse Block 15Kw			x			
8614-013	Fuse Block 20Kw				x		
8614-014	Fuse Block 25Kw					x	
8614-019	Fuse Block 30Kw						x
8604-014	Heat Strip 10Kw	x	x		(2)	x	
8604-015	Heat Strip 15Kw			x		x	(2)
8402-015	Limit Switch L130-2.0	(2)	(2)	(3)	(4)	(5)	(6)
8102-003	Motor 1/6 hp	x					
8105-012	Motor 1/3 hp		x	x	x		
8105-010	Motor 1/3 hp					x	x
8200-003	Motor Mount	x	x	x	x	x	x
5451-011	Motor Mounting Parts	x	x	x	x	x	x
8201-014	Relay - Blower	x	x	x	x	x	x
8401-017	Sequencer				x		x
8401-018	Sequencer	x	x			x	x
8401-019	Sequencer			x	x	x	x
8607-005	Terminal Board 24V	x	x	x	x	x	x
8607-001	Terminal Block 230V	x	x				
8402-018	Thermal Cut-off	(2)	(2)	(3)	(4)	(5)	(6)
8407-007	Transformer	x	x	x	x	x	x

\*Please Order by Model Number.

Minimum Net Billing \$15.00. Supersedes all previous lists.  
Subject to change without notice. F.O.B. Bryan, Ohio.

PARTS LIST  
LO-BOY GAS FURNACES

Effective 1/1/79  
Supersedes 1/

PART NO.	DESCRIPTION	G101	G127	G152
5153-012	Bearings 3/4"	x	x	x
5601-005	Belt 40"	x	x	
5601-001	Belt 36"			x
9010-014	Burner Venturi	x	x	
9010-002	Burner Venturi			x
5153-018	Collar 3/4"	x	x	x
5153-014	Cushion - Bearing	x	x	x
1171-003	Door Handles	x	x	x
1171-002	Door Pull	x	x	x
8402-004	Fan and Limit 8"	x		
8402-002	Fan and Limit 11"		x	x
7004-012	Filter 20x20	x		
7004-013	Filter 20x25		x	
7004-011	Filter 16x25			(2)
5451-001	Grommet - Blower Leg	x	x	x
9041-001	Heat Exchanger	x		
9041-002	Heat Exchanger		x	
9041-003	Heat Exchanger			x
*	Housing - Blower 10-10	x	x	
*	Housing - Blower 12-10			x
8406-013	Micro Switch	x	x	x
8102-001	Motor 1/6 hp	x		
8104-002	Motor 1/4 hp		x	
8105-002	Motor 1/3 hp			x
8200-014	Motor Adj. Kit	x	x	x
8200-016	Motor Mount	x	x	x
9010-006	Orifice Nat. #13 LP #34	x	x	x
8554-002	Pilot Burner - Nat.	x	x	x
5501-012	Pulley - Blower 6 x 3/4	x	x	x
5501-015	Pulley - Motor 3-1/4 x 1/2	x	x	x
1912-001	Shaft - Blower 15-1/4 x 3/4	x	x	x
8554-004	Thermocouple	x	x	x
8407-006	Transformer	x	x	x
5651-034	Valve - Nat 1/2 x 3/4	x	x	x
5153-002	Washer - Neoprene	x	x	x
5152-006	Wheel - Blower 10-10	x	x	
5152-022	Wheel - Blower 11-10			x

\*Please order by model number.  
Minimum Net Billing \$15.00 Supersedes all previous lists.  
Subject to change without notice. F.O.B. Bryan, Ohio

PARTS LIST  
ELECTRIC IGNITION  
LO-BOY GAS FURNACES

Effective 1/1/80  
Supersedes 1/1/79

PART NO.	DESCRIPTION	G101E	G127E	G152E
5153-012	Bearings 3/4"	x	x	x
5601-005	Belt 40"	x	x	
5601-001	Belt 36"			x
9010-014	Burner Venturi	x	x	
9010-002	Burner Venturi			x
5153-018	Collar 3/4"	x	x	x
5153-014	Cushion - Bearing	x	x	x
1171-003	Door Handles	x	x	x
1171-002	Door Pull	x	x	x
8402-004	Fan and Limit 8"	x		
8402-002	Fan and Limit 11"		x	x
7004-012	Filter 20x20	x		
7004-013	Filter 20x25		x	
7004-011	Filter 16x25			(2)
5451-001	Grommet - Blower Leg	x	x	x
9041-001	Heat Exchanger	x		
9041-002	Heat Exchanger		x	
9041-003	Heat Exchanger			x
*	Housing - Blower 10-10	x	x	
*	Housing - Blower 12-10			x
8600-005	Ignition Wire	x	x	
8600-006	Ignition Wire			x
8406-013	Micro Switch	x	x	x
5651-024	Module S86C1007	x	x	x
8102-001	Motor 1/6 hp	x		
8104-002	Motor 1/4 hp		x	
8105-002	Motor 1/3 hp			x
8200-014	Motor Adj. Kit	x	x	x
8200-016	Motor Mount	x	x	x
9010-006	Orifice Nat #13 LP #34	x	x	x
8554-009	Pilot & Orifice Nat-.020 LP-.014	x	x	x
5501-012	Pulley - Blower 6 x 3/4	x	x	x
5501-015	Pulley - Motor 3-1/4 x 1/2	x	x	x
1912-001	Shaft - Blower 15-1/4 x 3/4	x	x	x
8607-005	Terminal Block 0306001	x	x	x
8407-025	Transformer	x	x	x
5651-035	Valve - Nat 1/2 x 3/4	x	x	x
5153-002	Washer - Neoprene	x	x	x
5152-006	Wheel - Blower 10-10	x	x	
5152-022	Wheel - Blower 11-10			x

\*Please order by model number.

Minimum net billing \$15.00. Supersedes all previous lists.  
Subject to change without notice. F.O.B. Bryan, Ohio.



PARTS LIST  
HIGH-BOY GAS FURNACES

Effective 1/1/80  
Supersedes 1/1/79

PART NO.	DESCRIPTION	H6TSD2	H8TSD2	H8TSD3	HT06S	HT06SD2	HT06SD3	HT12S	HT12SD4	HT14S	HT16S	H20S
5153-012	Bearings 3/4"				x			x		x	x	
5601-001	Belt 36"				x			x		x	x	
5601-004	Belt 39"											x
8552-002	Capacitor 5/370V			x			x		x			
5153-018	Collar 3/4"				x			x		x	x	
5153-014	Cushion - Bearing				x			x		x	x	
8402-001	Fan and Limit 11"	x	x	x	x	x	x	x	x	x	x	
8402-004	Fan and Limit 8"											x
7004-001	Filter 16x25	x				x						
7003-004	Filter 16x25 P		x	x	x		x	x	x	x	x	x
9041-008	Heat Exchanger	x	x	x								
9041-009	Heat Exchanger				x	x	x	x	x			
9041-010	Heat Exchanger									x	x	
9041-023	Heat Exchanger											x
*	Housing - Blower 10-7	x	x	x		x						
*	Housing - Blower 10-9				x		x	x	x			
*	Housing - Blower 12-10									x	x	
*	Housing - Blower 12-12											x
5818-001	Manifold 3/4"	x	x	x								
5818-002	Manifold 3/4"				x	x	x	x	x			
5818-003	Manifold 3/4"									x	x	
5818-004	Manifold 3/4"											x
8102-005	Motor 1/6 hp	x	x			x						
8105-008	Motor 1/3 hp			x			x					
8104-002	Motor 1/4 hp				x							
8105-002	Motor 1/3 hp							x		x		
8106-001	Motor 1/2 hp										x	x
8105-009	Motor 1/3 hp								x			
5153-005	Motor Adjusting Brkt.				x			x		x	x	x
8200-003	Motor Mount	x	x	x		x	x		x			
8200-016	Motor Mount				x			x				
8200-013	Motor Mount									x	x	
5451-011	Motor Mtg. Parts	x	x	x		x	x		x			
9010-010	Orifice Nat	x										
9010-008	Orifice Nat		x	x				x	x		x	x
9010-009	Orifice Nat				x	x	x			x		
8406-013	Micro Switch	x	x	x	x	x	x	x	x	x	x	x
8554-002	Pilot Burner - Nat	x	x	x	x	x	x	x	x	x	x	x
5501-005	Pulley-Blower 6x3/4				x			x				
5501-012	Pulley-Blower 6x3/4											
5501-001	Pulley-Motor 3 1/2 x 1/2				x			x		x	x	x
5501-015	Pulley-Motor 3 1/2 x 1/2									x	x	x

\*Please order by model number.

PARTS LIST

HIGH-BOY GAS FURNACES

Effective 1/1/80  
Supersedes 1/1/79

PART NO.	DESCRIPTION	H61SD2	H81SD2	H81SD3	H106S	H106SD2	H106SD3	H121S	H121SD4	H141S	H161S	H201S
1912-001	Shaft -Blower 15¼ x 3/4				X			X				
1912-005	Shaft -Blower 16½ x 3/4									X	X	
8554-003	Thermocouple	X	X	X	X	X	X	X	X	X	X	X
8407-006	Transformer	X	X		X	X		X		X	X	X
8201-007	Transformer w/Relay	X	X		X	X		X		X	X	X
8201-006	Trans.w/2-speed Relay			X			X		X			
5651-032	Valve - Nat. 1/2 x 3/4	X	X	X	X	X	X	X	X	X	X	
5651-033	Valve - Nat 3/4 x 3/4											X
9010-015	Venturi 2-Cell	X	X	X								
9010-016	Venturi 3-Cell				X	X	X	X	X			
9010-017	Venturi 4-Cell									X	X	
9010-018	Venturi 5-Cell											X
5153-002	Washer - Neoprene				X			X		X	X	
5152-003	Wheel - Blower DD9-6A	X	X									
5152-004	Wheel - Blower DD9-7A					X						
5152-010	Wheel - Blower DD10-7A			X								
5152-002	Wheel - Blower A10-9A				X			X				
5152-014	Wheel - Blower DD10-9A						X		X			
5152-022	Wheel - Blower 11-10									X	X	
5152-042	Wheel - Blower CL1220											X

Minimum Net Billing \$15.00. Supersedes all previous lists.  
Subject to change without notice. F.O.B. Bryan, Ohio.

PARTS LIST  
ELECTRIC IGNITION  
HIGH-BOY GAS FURNACES

Effective 1/1/80  
Supersedes 1/1/79

PART NO.	DESCRIPTION	H61SD2E	H81SD2E	H81SD3E	H106SE	H106SD2E	H106SD3E	H121SE	H121SD4E	H141SE	H161SE	H201SE
5153-012	Bearing 3/4"				X			X		X	X	
5601-001	Belt 36"				X			X		X	X	
5601-004	Belt 39"											X
8552-002	Capacitor 5/370V			X			X		X			
5153-018	Collar 3/4"				X			X		X	X	
5153-002	Collar - Neoprene				X			X		X	X	
5153-014	Cushion - Bearing				X			X		X	X	
8402-001	Fan & Limit 11"	X	X	X	X	X	X	X	X	X	X	
8402-004	Fan & Limit 8"											X
7004-001	Filter 16x25	X				X						
7003-004	Filter 16x25 P		X	X	X		X	X	X	X	X	(2)
9041-008	Heat Exchanger	X	X	X								
9041-009	Heat Exchanger				X	X	X	X	X			
9041-010	Heat Exchanger									X	X	
9041-023	Heat Exchanger											
*	Housing - Blower 10-7	X	X	X		X						
*	Housing - Blower 10-9				X		X	X	X			
*	Housing - Blower 12-10									X	X	
*	Housing - Blower 12-12											X
5818-001	Manifold 3/4" NS2	X	X	X								
5818-002	Manifold 3/4" NS3				X	X	X	X	X			
5818-003	Manifold 3/4" NS4									X	X	
5818-004	Manifold 3/4" NS5											X
8102-005	Motor 1/6 hp	X	X			X						
8105-008	Motor 1/3 hp			X			X					
8104-002	Motor 1/4 hp				X							
8105-002	Motor 1/3 hp							X		X		
8105-009	Motor 1/3 hp								X			
8106-001	Motor 1/2 hp										X	X
5153-005	Motor Adj. Bracket				X			X		X	X	X
8200-003	Motor Mount	X	X	X		X	X		X			
5451-001	Motor Mounting Parts	X	X	X		X	X		X			
9010-010	Orifice Nat	X										
9010-008	Orifice Nat		X	X				X	X		X	X
9010-009	Orifice Nat				X	X	X	X	X	X	X	X
8554-009	Pilot Burner Nat	X	X	X	X	X	X	X	X	X	X	X
8600-001	Ignition Wire	X	X	X								
8600-002	Ignition Wire				X	X	X	X	X			
8600-003	Ignition Wire									X	X	
8600-004	Ignition Wire											X

\*Please order by model number.

PARTS LIST  
ELECTRIC IGNITION  
HIGH-BOY GAS FURNACES

Effective 1/1/80  
Supersedes 1/1/79

PART NO.	DESCRIPTION	H61SD2E	H81SD2E	H81SD3E	H106SE	H106SD2E	H106SD3E	H121SE	H121SD4E	H141SE	H161SE	H201SE
5651-024	Module	x	x	x	x	x	x	x	x	x	x	x
5501-005	Pulley-Blower 6 x 3/4				x			x				
5501-012	Pulley-Blower 6 x 3/4									x	x	x
5501-001	Pulley-Motor 3-1/4 x 1/2				x			x				
5501-015	Pulley-Motor 3-1/4 x 1/2									x	x	x
1912-001	Shaft 15-1/4 x 3/4				x			x				
1912-005	Shaft 16-1/2 x 3/4									x	x	
8407-025	Transformer	x	x		x	x		x		x	x	x
8207-006	Transformer w/Relay			x			x		x			
5651-023	Valve - Nat 1/2 x 3/4	x	x	x	x	x	x	x	x	x	x	x
8406-013	Micro Switch	x	x	x	x	x	x	x	x	x	x	x
9010-015	Venturi 2-Cell	x	x	x								
9010-016	Venturi 3-Cell				x	x	x	x	x			
9010-017	Venturi 4-Cell									x	x	
9010-018	Venturi 5-Cell											x
5152-003	Wheel DD9-6A	x	x									
5152-010	Wheel DD10-7A			x								
5152-002	Wheel A10-9				x			x				
5152-004	Wheel DD9-7A					x						
5152-014	Wheel DD10-9A						x		x			
5152-022	Wheel 11-10									x	x	
5152-042	Wheel - Blower CL1220											x
8607-005	Terminal Block	x	x	x	x	x	x	x	x	x	x	x

Minimum Net Billing \$15.00. Supersedes all previous lists.  
Subject to change without notice. F.O.B. Bryan, Ohio.

PARTS LIST  
COUNTERFLOW GAS FURNACES

Effective 1/1/75  
Supersedes 1/1/73

PART NO.	DESCRIPTION	C61SD2	C81SD2	C106SD3	C106S	C121S	C141S	C161S
5153-012	Bearings 3/4"				X	X	X	X
5601-005	Belt 40"				X	X		
5601-006	Belt 41"						X	X
8552-002	Capacitor 5/370V			X				
5153-018	Collar 3/4"				X	X	X	X
5153-014	Cushion, Bearing				X	X	X	X
8402-001	Fan and Limit 11"	X	X	X	X	X		
7003-001	Filter 10x20 P			X	X	X	X	X
7003-003	Filter 15x20	X	X	X	X	X	X	X
9041-005	Heat Exchanger	X	X					
9041-006	Heat Exchanger			X	X	X		
9041-007	Heat Exchanger						X	X
*	Housing - Blower 10-7	X	X					
*	Housing - Blower 10-9			X	X	X		
*	Housing - Blower 12-10						X	X
8402-014	Limit Switch	X	X	X	X	X	X	X
5818-001	Manifold	X	X					
5818-002	Manifold			X	X	X		
5818-003	Manifold						X	
8102-005	Motor 1/6 hp	X	X					
8105-008	Motor 1/3 hp			X				
8104-002	Motor 1/4 hp				X			
8105-002	Motor 1/3 hp					X	X	
8106-001	Motor 1/2 hp							X
5153-006	Motor Adj. Bracket				X	X	X	X
8200-003	Motor Mount	X	X	X				
8200-016	Motor Mount				X	X		
8200-013	Motor Mount						X	X
5451-011	Motor Mounting Parts	X	X	X				
9010-010	Orifice Nat	X						
9010-008	Orifice Nat		X			X		X
9010-009	Orifice Nat			X	X		X	
8402-004	Fan and Limit 8"						X	X
8554-002	Pilot Burner	X	X	X	X	X	X	X
8406-013	Micro Switch	X	X	X	X	X	X	X
5501-005	Pulley - Blower 6 x 3/4				X	X		
5501-001	Pulley - Motor 3-1/4 x 1/2				X	X		
5501-012	Pulley - Blower 6 x 3/4						X	X
5501-015	Pulley - Motor 3-1/4 x 1/2						X	X

\*Please order by model number.

PARTS LIST  
COUNTERFLOW GAS FURNACES

Effective T/1/80  
Supersedes 1/1/79

PART NO.	DESCRIPTION	C61SD2	C81SD2	C106SD3	C106S	C121S	C141S	C161S
1912-001	Shaft - Blower 15-1/4 x 3/4				X	X		
1912-005	Shaft - Blower 16-1/2 x 3/4						X	X
8554-003	Thermocouple	X	X	X	X	X	X	X
8407-006	Transformer	X	X		X	X	X	X
8201-007	Transformer w/Relay	X	X		X	X	X	X
8201-006	Transformer w/2-Speed Relay			X				
5651-032	Valve - Nat 1/2 x 3/4	X	X	X	X	X	X	X
9010-015	Venturi 2-Cell	X	X					
9010-016	Venturi 3-Cell			X	X	X		
9010-017	Venturi 4-Cell						X	X
5153-002	Washer-Neoprene				X	X	X	X
5152-003	Wheel - Blower DD9-6A	X	X					
5152-014	Wheel - Blower DD10-9A			X				
5152-002	Wheel - Blower 10-9A				X	X		
5152-022	Wheel - Blower 11-10						X	X

Minimum Net Billing \$15.00. Supersedes all previous lists.  
Subject to change without notice. F.O.B. Bryan, Ohio.

PARTS LIST  
ELECTRIC IGNITION  
COUNTERFLOW GAS FURNACES

Effective 1/1/80  
Supersedes 1/1/79

PART NO.	DESCRIPTION	C61SD2E	C81SD2E	C106SD3E	C106SE	C121SE	C141SE	C141S1E	C161SE	C161S1E
5153-012	Bearings 3/4"				X	X	X	X	X	X
5601-005	Belt 40"				X	X				
5601-006	Belt 41"						X	X		
5601-008	Belt 43"								X	X
8552-002	Capacitor 5/370V			X						
5153-018	Collar 3/4"				X	X	X	X	X	X
5153-002	Collar - Neoprene 3/4"				X	X	X	X	X	X
5153-014	Cushion, Bearing				X	X	X	X	X	X
8402-001	Fan and Limit 11"	X	X	X	X	X				
8402-004	Fan and Limit 8"						X	X	X	X
7003-001	Filter 10x20 P			X	X	X	X	X	X	X
7003-003	Filter 15x20 P	X	X	X	X	X	X	X	X	X
9041-005	Heat Exchanger	X	X							
9041-006	Heat Exchanger			X	X	X				
9041-007	Heat Exchanger						X	X	X	X
*	Housing - Blower 10-7	X	X							
*	Housing - Blower 10-9			X	X	X				
*	Housing - Blower 12-10						X	X	X	X
8600-001	Ignition Wire	X	X							
8600-002	Ignition Wire			X	X	X				
8600-003	Ignition Wire						X	X	X	X
8402-014	Limit Switch 140°	X	X	X	X	X	X	X	X	X
5818-001	Manifold NS2	X	X							
5818-002	Manifold NS3			X	X	X				
5818-003	Manifold NS4						X	X	X	X
8406-013	Micro Switch	X	X	X	X	X	X	X	X	X
8102-005	Motor 1/6 hp	X	X							
8105-008	Motor 1/3 hp			X						
8104-002	Motor 1/4 hp				X					
8105-002	Motor 1/3 hp					X	X			
8106-001	Motor 1/2 hp							X		
8107-001	Motor 3/4 hp								X	X
5153-006	Motor Adj. Brkt.				X	X	X	X	X	X
8200-003	Motor Mount	X	X	X						
5451-011	Motor Mounting Parts	X	X	X						
5651-024	Module - Nat	X	X	X	X	X	X	X	X	X
9010-010	Orifice - Nat	X								
9010-008	Orifice - Nat		X			X			X	X
9010-009	Orifice - Nat			X	X		X	X		
8554-009	Pilot and Orifice Nat.	X	X	X	X	X	X	X	X	X

\*Please order by model number.

PARTS LIST  
ELECTRIC IGNITION  
COUNTERFLOW GAS FURNACES

Effective 1/1/80  
Supersedes 1/1/79

PART NO.	DESCRIPTION	C61SD2E	C81SD2E	C106SD3E	C106SE	C121SE	C141SE	C141S1E	C161SE	C161S1E
5501-005	Pulley - Blower 6 x 3/4				x	x				
5501-012	Pulley - Blower 6 x 3/4						x	x	x	x
5501-001	Pulley - Motor 3-1/4 x 1/2				x	x				
5501-015	Pulley - Motor 3-1/4 x 1/2						x	x		
5501-016	Pulley - Motor 4 x 5/8								x	x
1912-001	Shaft 15-1/4 x 3/4				x	x				
1912-005	Shaft 16-1/2 x 3/4						x	x	x	x
8607-005	Terminal Block	x	x	x	x	x	x	x	x	x
8407-025	Transformer 20VA	x	x		x	x	x	x	x	x
8201-006	Fan Relay w/Trans.			x						
5651-023	Valve - Nat. 1/2 x 3/4	x	x	x	x	x	x	x	x	x
9010-015	Venturi 2-Cell	x	x							
9010-016	Venturi 3-Cell			x	x	x				
9010-017	Venturi 4-Cell						x	x	x	x
5152-003	Wheel DD9-6A	x	x							
5152-014	Wheel DD10-9A			x						
5152-002	Wheel A10-9A				x	x				
5152-022	Wheel 11-10						x	x	x	x

Minimum Net Billing \$15.00. Supersedes all previous lists.  
Subject to change without notice. F.O.B. Bryan, Ohio



PARTS LIST  
GAS HORIZONTAL

Effective 1/1/80  
Supersedes 1/1/79

PART NO.	DESCRIPTION	HG75D4	HG100D4	HG120D4	HG140D4	HG160D2
205456	Capacitor 6/370V	x	x	x	x	
205803	Capacitor 7.5/370V					x
212710	Fan & Limit L4064A1321	x	x	x	x	x
202658	Auxiliary Limit WALL 130	x	x	x	x	x
2168882	Heat Exchanger	x				
2068892	Heat Exchanger		x			
2168902	Heat Exchanger			x		
2168912	Heat Exchanger				x	
2168922	Heat Exchanger					x
2168411	Blower Lau 10-6	x				
2168431	Blower Lau 10-7		x			
203320	Blower Lau 12-9			x		
2168441	Blower Lau 10-10				x	
203418	Blower Lau 12-12					x
2032682	Motor 1/4 hp 4 Speed	x				
2032692	Motor 1/3 hp 4 Speed		x	x	x	
2033222	Motor 3/4 hp 2 Speed					x
203425	Motor Mount Kit	x	x	x	x	
203426	Motor Mount Kit					x
202699	Orifice Nat. 43	(3)	(4)	(5)	(6)	(7)
202671	Orifice LP 54	(3)	(4)	(5)	(6)	(7)
202668	Pilot Nat. Q314A4222	x	x	x	x	x
202669	Pilot LP Q314A3778	x	x	x	x	x
202863	Thermocouple Q309A2143	x	x	x	x	x
202829	Transformer AT20A1005	x	x	x	x	x
202881	Gas Valve Nat. V810A1012	x	x	x	x	
202883	Gas Valve LP V810B1011	x	x	x	x	
202882	Gas Valve Nat. V810A1004					x
202884	Gas Valve LP V810B1003					x
203356	Blower Wheel 10-6	x				
203357	Blower Wheel 10-7		x			
203369	Blower Wheel 12-9			x		
203360	Blower Wheel 10-10				x	
203362	Blower Wheel 12-12					x
2165881	Burner Venturi w/Air Shutter	x	x	x	x	x
203049	Filter Opt. 10x20x1	(2)	(2)			
203048	Filter Opt. 14x20x1			(2)	(2)	
203052	Filter Opt. 16x20x1					(2)
216671	LP Conversion Kit	x	x	x	x	x
216041	Filter Support (Opt) pr.	x				
216051	Filter Support (Opt) pr.		x			
216061	Filter Support (Opt) pr.			x		
216071	Filter Support (Opt) pr.				x	
216081	Filter Support (Opt) pr.					x

NOTE: Always furnish model and serial number when ordering parts.  
Optional 2 speed relay with transformer available for  
air conditioning, part number 8201-006.

PARTS LIST  
ELECTRIC IGNITION  
GAS HORIZONTAL

Effective 1/1/80

PART NO.	DESCRIPTION	HG75D4E	HG100D4E	HG120D4E	HG140D4E	HG160D2E
205456	Capacitor 6/370V	x	x	x	x	
205803	Capacitor 7.5/370V					x
212710	Fan & Limit L4064A1321	x	x	x	x	x
202658	Auxiliary Limit Wall 130	x	x	x	x	x
2168882	Heat Exchanger	x				
2068892	Heat Exchanger		x			
2168902	Heat Exchanger			x		
2168912	Heat Exchanger				x	
2168922	Heat Exchanger					x
2168411	Blower Lau 10-6	x				
2168431	Blower Lau 10-7		x			
203320	Blower Lau 12-9			x		
2168441	Blower Lau 10-10				x	
203418	Blower Lau 12-12					x
2032682	Motor 1/4 hp 4 Speed	x				
2032692	Motor 1/3 hp 4 Speed		x	x	x	
2033222	Motor 3/4 hp 2 Speed					x
203425	Motor Mount Kit	x	x	x	x	
203426	Motor Mount Kit					x
202699	Orifice Nat. 43	(3)	(4)	(5)	(6)	(7)
202671	Orifice LP 54	(3)	(4)	(5)	(6)	(7)
202945	Orifice Nat WRA69-1863 (WR)	x	x	x	x	x
202946	Orifice LP WRA69-2052 (WR)	x	x	x	x	x
202944	WR3098 Auto Sensor (WR)	x	x	x	x	x
202829	Transformer AT20A1005	x	x	x	x	x
202941	Gas Valve Nat. (WR)	x	x	x	x	x
202942	Gas Valve LP (WR)	x	x	x	x	x
202917	Gas Valve Nat. MH V845P1038 (H)	x	x	x	x	x
202924	Gas Valve LP MH V845P1020 (H)	x	x	x	x	x
203356	Blower Wheel 10-6	x				
203357	Blower Wheel 10-7		x			
203369	Blower Wheel 12-9			x		
203360	Blower Wheel 10-10				x	
203362	Blower Wheel 12-12					x
2165881	Burner Venturi w/Air Shutter	x	x	x	x	x
203049	Filter Opt. 10x20x1	(2)	(2)			
203048	Filter Opt. 14x20x1			(2)	(2)	
203052	Filter Opt. 16x20x1					(2)
206075	LP Conversion Kit	x	x	x	x	x
216041	Filter Support (Opt) pr.	x				
216051	Filter Support (Opt) dr.		x			
216061	Filter Support (Opt) pr.			x		
216071	Filter Support (Opt) pr.				x	
216081	Filter Support (Opt) dr.					x

NOTE: Always furnish model and serial number when ordering parts.  
Optional 2 speed relay with transformer available for  
air conditioning, part number 8201-006.

PARTS LIST  
ELECTRIC IGNITION  
GAS HORIZONTAL

Effective 1/1/8

PART NO.	DESCRIPTION	HG75D4E	HG100D4E	HG120D4E	HG140D4E	HG160D2E
202939	Pilot Assembly - Nat (WR)	x	x	x	x	x
202940	Pilot Assembly - LP (WR)	x	x	x	x	x
202943	Safety Control WR50A22 (WR)	x	x	x	x	x
2169885	Burner Rack Manifold Assy. (H)	x				
2169895	Burner Rack Manifold Assy. (H)		x			
2169905	Burner Rack Manifold Assy. (H)			x		
2169915	Burner Rack Manifold Assy. (H)				x	
2159925	Burner Rack Manifold Assy. (H)					x
2169936	L.P. MH Electric Igniter (H)	x				
2169946	L.P. MH Electric Igniter (H)		x			
2169956	L.P. MH Electric Igniter (H)			x		
2169966	L.P. MH Electric Igniter (H)				x	
2169976	L.P. MH Electric Igniter (H)					x
202919	Sensor Q354A MH (H)	x	x	x	x	x
202920	Igniter Q330E (H)	x	x	x	x	x
202921	Lockout Module S825C (H)	x	x	x	x	x
202927	Regularot - 2.2" LP (H)	x	x	x	x	x
206070	Igniter Sensor Assy. (H)	x	x	x		
206071	Igniter Sensor Assy. (H)				x	
206065	Igniter Wire Assy. (H)	x	x	x	x	x
206066	Sensor Wire Assy. (H)	x	x	x	x	x
206067	Wire Assy. Module to Valve (H)	(2)	(2)	(2)	(2)	(2)

Minimum Net Billing \$15.00. Supersedes all previous lists.  
Subject to change without notice. F.O.B. Bryan, Ohio.

PARTS LIST  
OIL FURNACES

Effective 1/1/80  
Supersedes 1/1/79

PART NO.	DESCRIPTION	F81	F97	NB120	C1	C2	F86CF	F100CF	F86H	F120H	F120L	HZ95
5153-012	Bearings 3/4"	x	x	x			x	x	x	x	x	x
5153-013	Bearings 1"				x	x						
5601-007	Belt 42"	x										
5601-001	Belt 36"								x		x	
5601-003	Belt 38"			x								
5601-009	Belt 46"				x	x						
5601-005	Belt 40"		x				x	x				
5601-002	Belt 37"									x		
5601-004	Belt 39"											x
5153-018	Collar 3/4"	x	x	x			x	x	x	x	x	x
5153-021	Collar 1"				x	x						
7090-005	Combustion Chamber	x	x				x	x	x			
7090-003	Combustion Chamber			x						x	x	
7090-006	Combustion Chamber				x	x						
7090-002	Combustion Chamber											x
5153-014	Cushion - Bearing	x	x	x			x	x	x	x	x	x
5153-015	Cushion - Bearing				x	x						
8402-004	Fan and Limit 8"						x	x				
8402-002	Fan and Limit 11"	x	x		x	x					x	
8402-003	Fan and Limit L4064B								x			
8402-005	Fan and Limit L4064C			x						x		x
7004-012	Filter 20x20	x		(2)						x		
7004-013	Filter 20x25		x									x
7004-011	Filter 16x25				(2)				x		(2)	
7004-001	Filter 10x20						(2)					
7004-003	Filter 12x20							(2)				
7003-004	Filter 16x25 P					(2)						
7004-010	Filter 16x20									x		
1171-002	Handle - Door	x	x	x							x	
1171-003	Handle - Door	(2)	(3)	(2)	(4)	(4)	(2)	(2)	(2)		(2)	
9041-001	Heat Exchanger	x					x		x			
9041-022	Heat Exchanger		x									
9041-017	Heat Exchanger			x								
9041-018	Heat Exchanger				x							
9041-019	Heat Exchanger					x						
9041-021	Heat Exchanger							x				
9041-016	Heat Exchanger									x		
9041-003	Heat Exchanger										x	
9041-011	Heat Exchanger											x
*	Housing - Blower 10-10	x	x				x	x	x			x
*	Housing - Blower 12-10			x						x	x	
*	Housing - Blower 140-14				x	x						

\*Please order by model number.

PARTS LIST  
OIL FURNACES

Effective 1/1/80  
Supersedes 1/1/

PART NO.	DESCRIPTION	F81	F97	NB120	C1	C2	F86CF	F100CF	F86H	F120H	F120L	HZ95
8102-001	Motor 1/6 hp	x										
8104-002	Motor 1/4 hp		x				x	x	x			x
8104-001	Motor 1/4 hp			x								
8105-001	Motor 1/3 hp				x	x						
8105-002	Motor 1/3 hp									x	x	
8106-001	Motor 1/2 hp									x		
8200-014	Motor Adj. Kit	x	x	x	x	x	x	x	x	x	x	x
9011-001	Nozzle	x					x		x			
9011-002	Nozzle		x					x				x
9011-004	Nozzle			x						x	x	
9011-006	Nozzle				x							
9011-009	Nozzle					x						
5501-013	Pulley-Blower 7 x 3/4	x		x								
5501-012	Pulley-Blower 6 x 3/4		x				x	x	x	x	x	x
5501-014	Pulley-Blower 8 x 1				x	x						
5501-015	Pulley-Motor 3-1/4 x 1/2	x	x	x	x	x	x	x	x	x	x	x
8400-001	Relay	x	x	x	x	x	x	x	x	x	x	x
8400-002	Sensor Cell	x	x	x	x	x	x	x	x	x	x	x
1912-001	Shaft-Blower 15 1/2 x 3/4	x	x				x	x	x		x	
1912-005	Shaft-Blower 16 1/2 x 3/4			x								
1912-006	Shaft-Blower 20 x 1				x	x				x		
8402-022	Upper Limit L145-2.5						x	x				
5153-002	Washer - Neoprene	x	x	x			x	x	x	x	x	x
5153-003	Washer - Neoprene				x	x						
5152-006	Wheel - Blower 10-10	x	x				x	x	x			x
5152-022	Wheel - Blower 11-10			x						x	x	
5152-025	Wheel - Blower 140-14				x	x						
9020-010	MSR 6" Oil Burner		x					x				
9020-009	MSR 8" Oil Burner	x					x		x			
9020-012	MSR 6" Oil Burner			x	x	x			x			
9020-011	MSR 8" Oil Burner											
9020-002	OEA 6" Oil Burner									x	x	x

NOTE: For oil burner parts, see oil burner parts list.

Minimum Net Billing \$15.00. Supersedes all previous lists.  
Subject to change without notice. F.O.B. Bryan, Ohio.

PARTS LIST  
HORIZONTAL SERIES  
OIL FURNACES

Effective 1/1/80  
Supersedes 1/1/79

PART NO.	DESCRIPTION	S0175	S0230	S0350
HE175S	Heat Exchanger Steel Body	x		
HE203S	Heat Exchanger Steel Body		x	
HE350S	Heat Exchanger Steel Body			x
AGOF	Door Frame Gasket 1/8 x 1-1/4	x	x	x
216061	Lower Oil Burning Mounting Door	x	x	x
216062	Upper Oil Burner Mounting Door	x	x	x
B1212	Blower Assembly w/Wheel	x		
B1215	Blower Assembly w/Wheel		x	
B1218	Blower Assembly w/Wheel			x
B1212MB	Blower Motor Mount Bar	x		
B1215MB	Blower Motor Mount Bar		x	
B1218MB	Blower Motor Mount Bar			x
BHB	Blower Motor Adj. Hardware	x	x	x
L4064	Fan & Limit Control	x	x	x
T87F	Room Thermostat	x	x	x
BM 1/3hp	Blower Motor	x		
BM 1/2hp	Blower Motor		x	
BM 3/4hp	Blower Motor			x
20x25x1	Air Filter	x		
16x25x1	Air Filter		x	
16x16x1	Air Filter			x
DH01	Door Handles w/Keepers	x	x	x
FC8	Finish Collar	x	x	
FC9	Finish Collar			x
BD06	Blower Door (Less Handles)	x		
BD07	Blower Door (Less Handles)		x	
BD08	Blower Door (Less Handles)			x
F104	Fire Brick	x		
F150	Fire Brick		x	
F350	Fire Brick			x
VER2	Vermiculite	x		
VER3	Vermiculite		x	
VER4	Vermiculite			x
HTC	Hi Temp Cement	x	x	x
BDP175S	Blower Division Panel	x		
BDP230S	Blower Division Panel		x	
BDP350S	Blower Division Panel			x
CB175S	Cabinet Base	x		
CB230S	Cabinet Base		x	
CB350S	Cabinet Base			x
BP7	Blower Drive Pulley	x	x	
BP8	Blower Drive Pulley			x
MP01	Motor Drive Pulley	x	x	
MP02	Motor Drive Pulley			x

PARTS LIST  
HORIZONTAL SERIES  
OIL FURNACES

Effective 1/1/80  
Supersedes 1/1/79

PART NO.	DESCRIPTION	S0175	S0230	S0350
WHO2	Wiring Harness (Complete)	x	x	x
FB	Fan Belt	x	x	x
CTS175	Cabinet Top	x		
CTS230	Cabinet Top		x	
CTS350	Cabinet Top			x
FP175S	Front Panel	x		
FP230S	Front Panel		x	
FP350S	Front Panel			x
BD06	Blower Door	x		
BD07	Blower Door		x	
BD08	Blower Door			x
RSP175S	Right Side Panel	x		
RSP230S	Right Side Panel		x	
RSP350S	Right Side Panel			x
LSP175S	Left Side Panel	x		
LSP230S	Left Side Panel		x	
LSP350S	Left Side Panel			x
IDP175S	Inner Division Panel	x		
IDP230S	Inner Division Panel		x	
IDP350S	Inner Division Panel			x
RP175S	Rear Panel	x		
RP230S	Rear Panel		x	
RP350S	Rear Panel			x
SRO1	Support Rails	x	x	x
PA02	W.A. Plenum Adapter	x		
PA03	W.A. Plenum Adapter		x	
PA04	W.A. Plenum Adapter			x

Minimum Net Billing \$15.00. Supersedes all previous lists.  
Subject to change without notice. F.O.B. Bryan, Ohio

MODEL MSR 8"  
 SPEC. #129-029  
 BARD #9020-009

<u>Item No.</u>	<u>Description</u>	<u>Part No.</u>
1	Motor, Marathon 1/8 HP - 115V - 1 PH - 60CY - 3450 RPM	20627
2	Motor Mtg. Hex Hd. Machine Screw, 5/16-18 x 1"	12701
3	Motor Cord Cover	13029
4	Transformer, France - 115V - 60CY	20593
5	Transformer Hinge Screw	12695
6	Transformer Hold Down Screw	12697
7	Fan Set Screw (Included w/Fan)	-
8	Fan	20673
9	Transformer Front Hold Down Clip Screw	13423
10	Transformer Front Hold Down Clip	13472
11	Fan Housing	4811
12	Oil Line Slot Cover	13392
13	Oil Line Locknut	14296
14	Oil Line Slot Cover Screw	12697
15	Air Adjusting Band - Inner	20601
16	Air Adjusting Band Machine Screw	12701
17	Air Adjusting Band - Outer	20602
18	Oil Line Assembly	14451
19	Coupling	13424
20	Fuel Unit	13495
21	Fuel Unit Mtg. Screw	12701
22	Oil Line Elbow	13494
23	Speed Nut	N/A
24	Oil Pipe	21410-20
25	Buss Bar	100004-8
26	Set Screw (Included w/Electrode Support)	-
27	Rd. Hd. Machine Screw, #10-24 x 3/8"	12694
28	Electrode Support (Tripod)	21407-1
29	Baffle Plate - 3-11/16"	13406
30	Rd. Hd. Thread Ctg. Machine Screw #4-40 x 5/16"	12695
31	Insulator	100005-1
32	Electrode Stem	13163
33	Nozzle Adapter	I2362
34	Insulator Bushing	12408
35	Palnut	13110
36	Oil Line Fitting	14295
37	Air Cone Mtg. Screw, Flat Head #8-32 x 5/16"	14116
38	Flange Mtg. Screw, Flat Head, 5/16-18 x 5/8"	12700
39	Gasket	N/A
40	Mtg. Flange	20640
41	Air Cone	14157
42	Air Tube	21005
43	Gun Assy.	30504-83



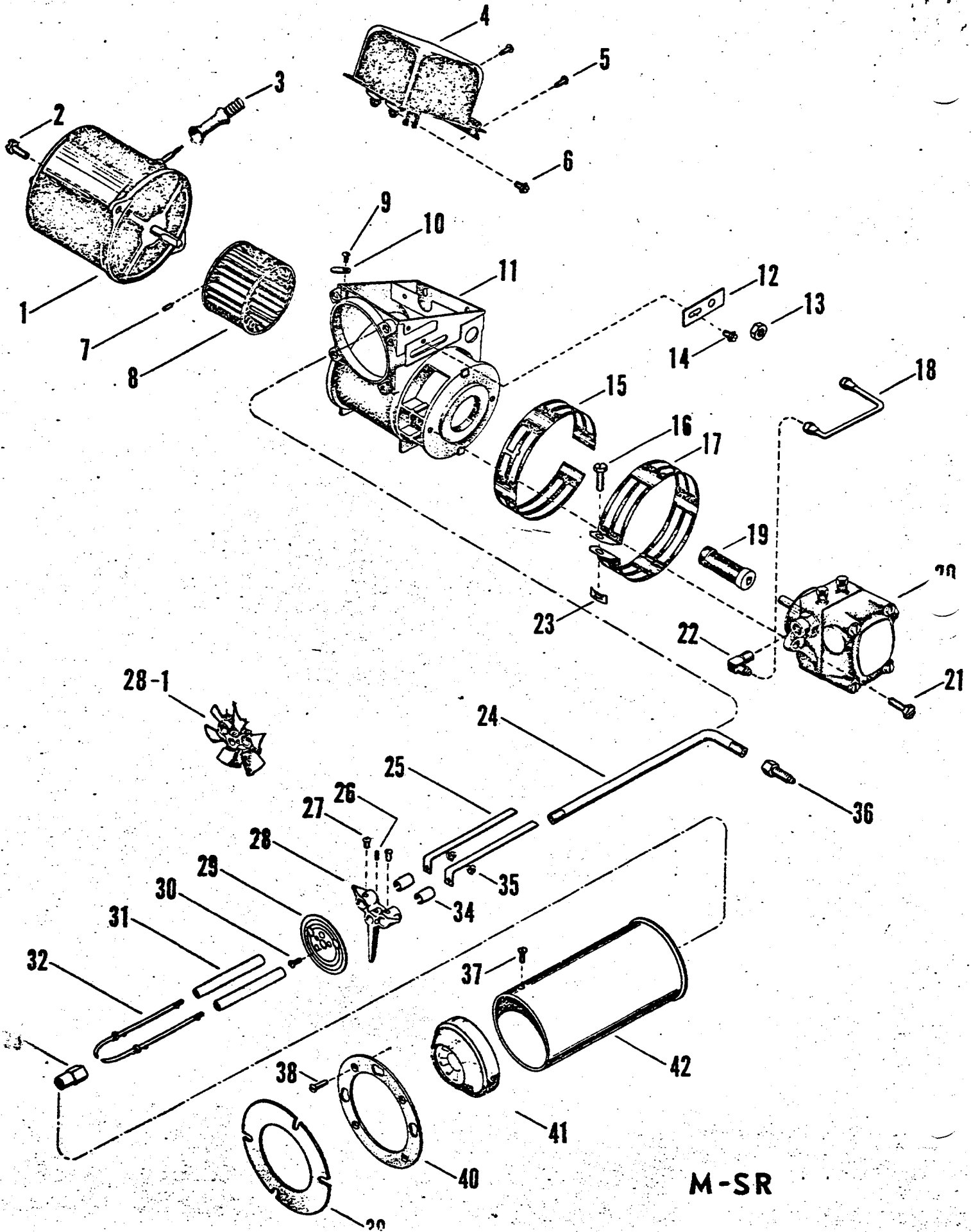

M-SR

MODEL MSR 6"  
 SPEC. #129-031  
 BARD #9020-010

<u>Item No.</u>	<u>Description</u>	<u>Part No.</u>
1	Motor, Marathon 1/8 HP - 115V - 1 PH - 60CY - 3450 RPM	20627
2	Motor Mtg. Hex Hd. Machine Screw, 5/16-18 x 1"	12701
3	Motor Cord Cover	13029
4	Transformer, France - 115V - 60CY	20593
5	Transformer Hinge Screw	12695
6	Transformer Hold Down Screw	12697
7	Fan Set Screw (Included w/Fan)	-
8	Fan	20673
9	Transformer Front Hold Down Clip Screw	13423
10	Transformer Front Hold Down Clip	13472
11	Fan Housing	4811
12	Oil Line Slot Cover	13392
13	Oil Line Locknut	14296
14	Oil Line Slot Cover Screw	12697
15	Air Adjusting Band - Inner	20601
16	Air Adjusting Band Machine Screw	12701
17	Air Adjusting Band - Outer	20602
18	Oil Line Assembly	14451
19	Coupling	13424
20	Fuel Unit	13495
21	Fuel Unit Mtg. Screw	12701
22	Oil Line Elbow	13494
23	Speed Nut	N/A
24	Oil Pipe	21410-11
25	Buss Bar	100004-3
26	Set Screw (Included w/Electrode Support)	-
27	Rd. Hd. Machine Screw, #10-24 x 3/8"	12694
28	Electrode Support (Tripod)	21407-1
29	Baffle Plate - 3-11/16"	13406
30	Rd. Hd. Thread Ctg. Machine Screw #4-40 x 5/16"	12695
31	Insulator	100005-1
32	Electrode Stem	13163
33	Nozzle Adapter	12362
34	Insulator Bushing	12408
35	Palnut	13110
36	Oil Line Fitting	14295
37	Air Cone Mtg. Screw, Flat Head #8-32 x 5/16"	14116
38	Flange Mtg. Screw, Flat Head, 5/16-18 x 5/8"	12700
39	Gasket	N/A
40	Mtg. Flange	20640
41	Air Cone	14157
42	Air Tube	20989
43	Gun Assy.	30504-54

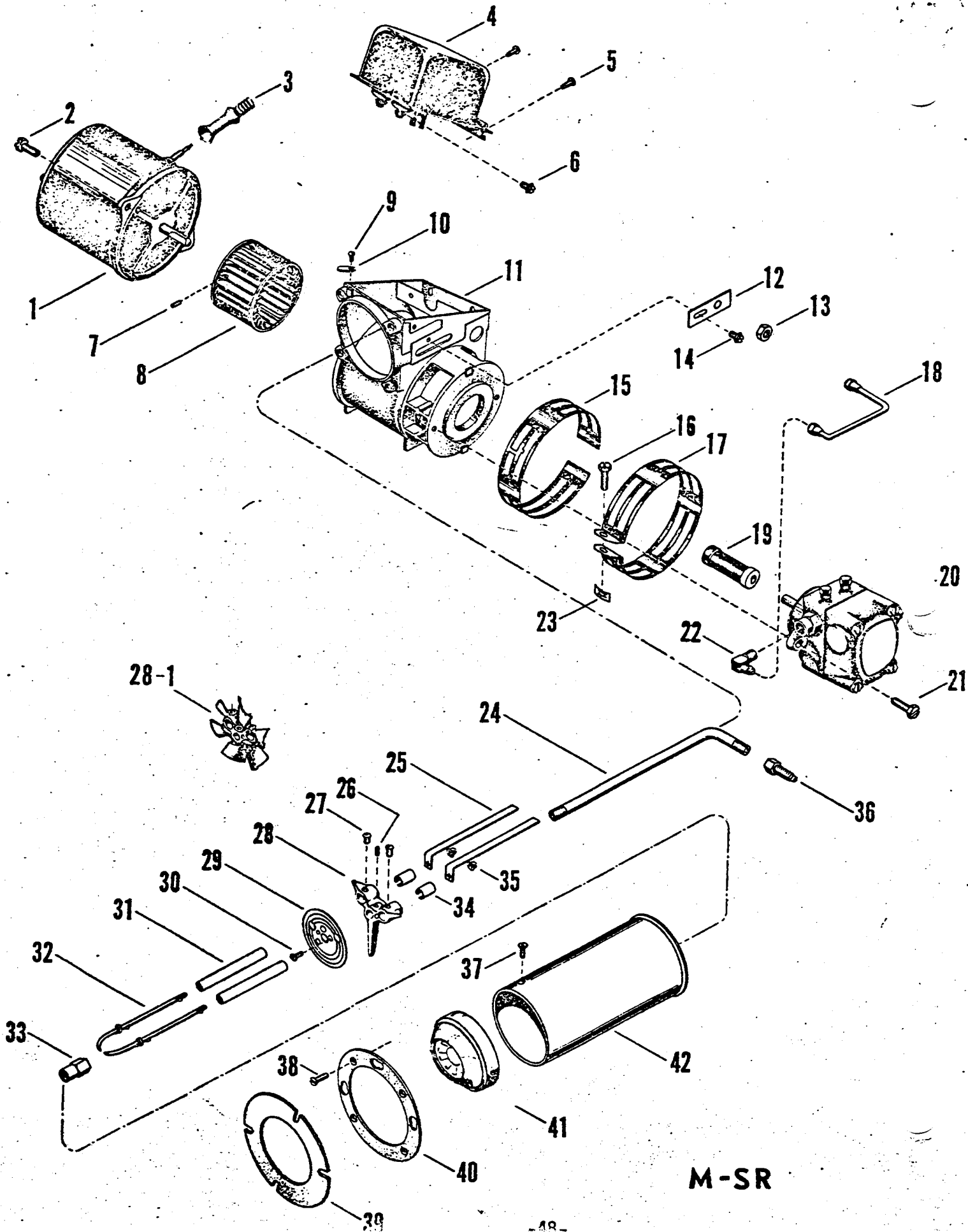

M-SR

MODEL MSR 8"  
 SPEC. #129-033  
 BARD #9020-011

<u>Item No.</u>	<u>Description</u>	<u>Part No.</u>
1	Motor, Marathon 1/8 HP - 115V - 1 PH - 60CY - 3450 RPM	20627
2	Motor Mtg. Hex Hd. Machine Screw, 5/16-18 x 1"	12701
3	Motor Cord Cover	13029
4	Transformer, France - 115V - 60CY	20593
5	Transformer Hinge Screw	12695
6	Transformer Hold Down Screw	12697
7	Fan Set Screw (Included w/Fan)	-
8	Fan	20673
9	Transformer Front Hold Down Clip Screw	13423
10	Transformer Front Hold Down Clip	13472
11	Fan Housing	4811
12	Oil Line Slot Cover	13392
13	Oil Line Locknut	14296
14	Oil Line Slot Cover Screw	12697
15	Air Adjusting Band - Inner	20601
16	Air Adjusting Band Machine Screw	12701
17	Air Adjusting Band - Outer	20602
18	Oil Line Assembly	14451
19	Coupling	13424
20	Fuel Unit	13495
21	Fuel Unit Mtg. Screw	12701
22	Oil Line Elbow	13494
23	Speed Nut	N/A
24	Oil Pipe	21410-20
25	Buss Bar	100004-8
26	Set Screw (Included w/Electrode Support)	-
27	Rd. Hd. Machine Screw, #10-24 x 3/8"	12694
28	Electrode Support (Tripod)	21407-1
29	Baffle Plate - 3"	13408
30	Rd. Hd. Thread Ctg. Machine Screw #4-40 x 5/16"	12695
31	Insulator	100005-1
32	Electrode Stem	13163
33	Nozzle Adapter	12362
34	Insulator Bushing	12408
35	Palnut	13110
36	Oil Line Fitting	14295
37	Air Cone Mtg. Screw, Flat Head #8-32 x 5/16"	14116
38	Flange Mtg. Screw, Flat Head, 5/16-18 x 5/8"	12700
39	Gasket	N/A
40	Mtg. Flange	20640
41	Air Cone	14158
42	Air Tube	21005
43	Gun Assy.	30504-81

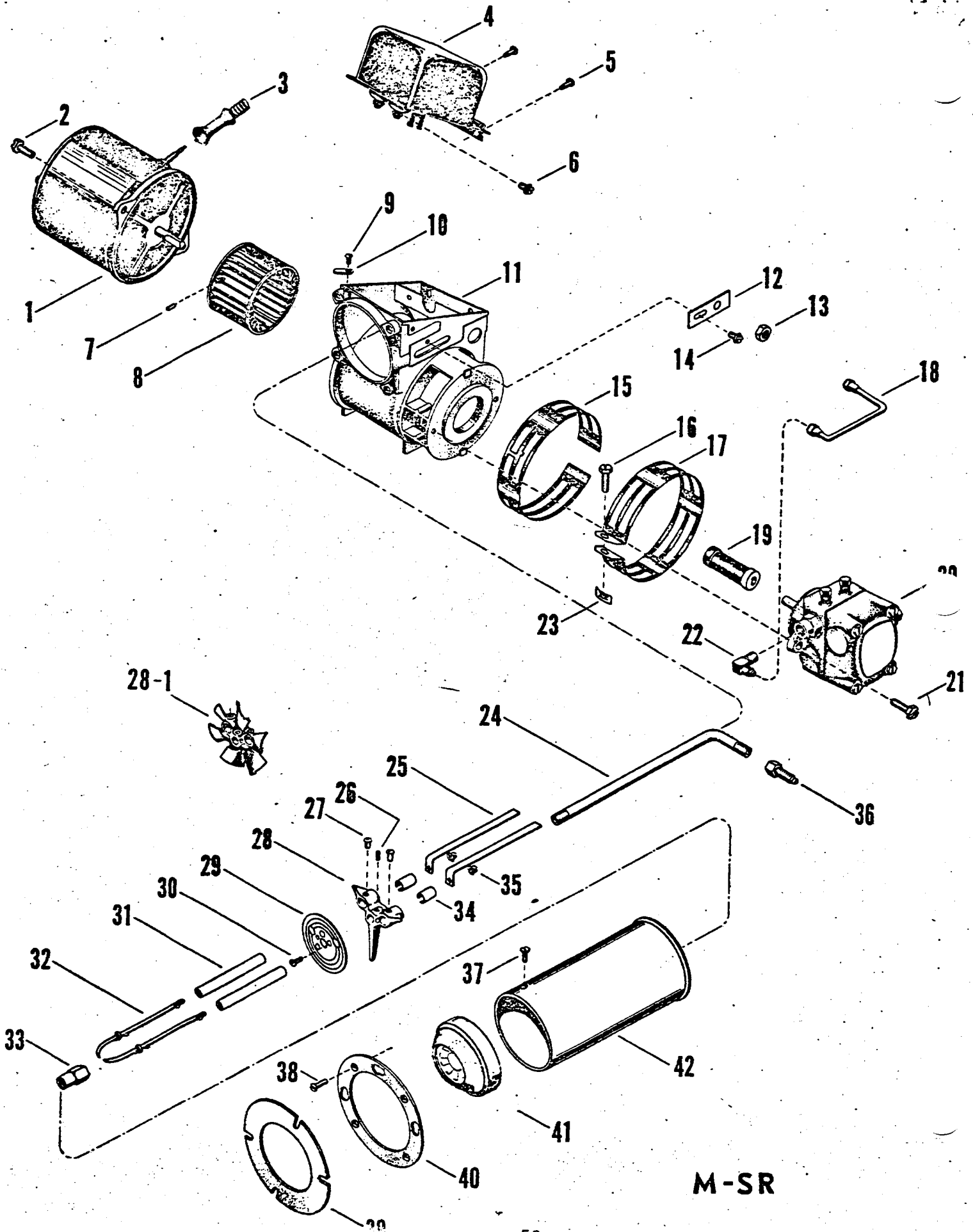

M-SR

## MODEL MSR 6"

SPEC. #129-037

BARD #9020-012

<u>Item No.</u>	<u>Description</u>	<u>Part No.</u>
1	Motor, Marathon 1/8 HP - 115V - 1 PH - 60CY - 3450 RPM	20627
2	Motor Mtg. Hex Hd. Machine Screw, 5/16-18 x 1"	12701
3	Motor Cord Cover	13029
4	Transformer, France - 115V - 60CH	20593
5	Transformer Hinge Screw	12695
6	Transformer Hold Down Screw	12697
7	Fan Set Screw (Included w/Fan)	-
8	Fan	20673
9	Transformer Front Hold Down Clip Screw	13423
10	Transformer Front Hold Down Clip	13472
11	Fan Housing	4811
12	Oil Line Slot Cover	13392
13	Oil Line Locknut	14296
14	Oil Line Slot Cover Screw	12697
15	Air Adjusting Band - Inner	20601
16	Air Adjusting Band Machine Screw	12701
17	Air Adjusting Band - Outer	20602
18	Oil Line Assembly	14451
19	Coupling	13424
20	Fuel Unit	13495
21	Fuel Unit Mtg. Screw	12701
22	Oil Line Elbow	13494
23	Speed Nut	N/A
24	Oil Pipe	21410-11
25	Buss Bar	100004-3
26	Set Screw (Included w/Electrode Support)	-
27	Rd. Hd. Machine Screw, #10-24 x 3/8"	12694
28	Electrode Support (Tripod)	21407-1
29	Baffle Plate - 3"	13408
30	Rd. Hd. Thread Ctg. Machine Screw #4-40 x 5/16"	12695
31	Insulator	100005-1
32	Electrode Stem	13163
33	Nozzle Adapter	12362
34	Insulator Bushing	12408
35	Palnut	13110
36	Oil Line Fitting	14295
37	Air Cone Mtg. Screw, Flat Head #8-32 x 5/16"	14116
38	Flange Mtg. Screw, Flat Head, 5/16-18 x 5/8"	12700
39	Gasket	N/A
40	Mtg. Flange	20640
41	Air Cone	14158
42	Air Tube	20989
43	Gun Assy.	30504-19

Effective 1/1/80

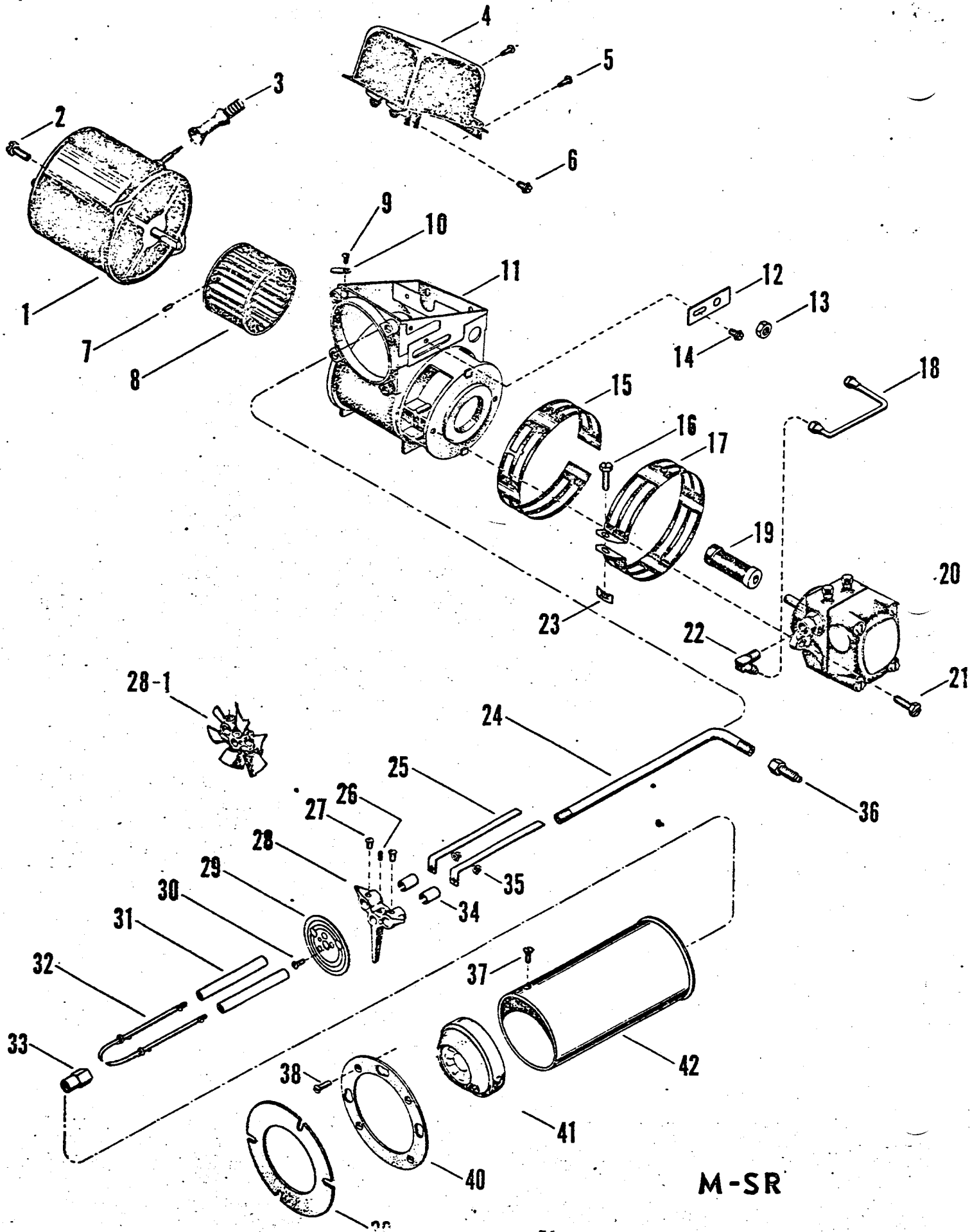

M-SR

MODEL MSR 6"  
 SPEC. #129-035  
 BARD #9020-013

<u>Item No.</u>	<u>Description</u>	<u>Part No.</u>
1	Motor, Marathon 1/8 HP - 115V - 1 PH - 60CY - 3450 RPM	20627
2	Motor Mtg. Hex Hd. Machine Screw, 5/16-18 x 1"	12701
3	Motor Cord Cover	13029
4	Transformer, France - 115V - 60CY	20593
5	Transformer Hinge Screw	12695
6	Transformer Hold Down Screw	12697
7	Fan Set Screw (Included w/Fan)	-
8	Fan	20673
9	Transformer Front Hold Down Clip Screw	13423
10	Transformer Front Hold Down Clip	13472
11	Fan Housing	4811
12	Oil Line Slot Cover	13392
13	Oil Line Locknut	14296
14	Oil Line Slot Cover Screw	12697
15	Air Adjusting Band - Inner	20601
16	Air Adjusting Band Machine Screw	12701
17	Air Adjusting Band - Outer	20602
18	Oil Line Assembly	14451
19	Coupling	13424
20	Fuel Unit	13495
21	Fuel Unit Mtg. Screw	12701
22	Oil Line Elbow	13494
23	Speed Nut	N/A
24	Oil Pipe	21410-11
25	Buss Bar	100004-3
26	Set Screw (Included w/Electrode Support)	-
27	Rd. Hd. Machine Screw, #10-24 x 3/8"	12694
28	Electrode Support (Tripod)	21407-1
29	Baffle Plate - 2"	13407
30	Rd. Hd. Thread Ctg. Machine Screw #4-40 x 5/16"	12695
31	Insulator	100005-1
32	Electrode Stem	13163
33	Nozzle Adapter	12362
34	Insulator Bushing	12408
35	Palnut	13110
36	Oil Line Fitting	14295
37	Air Cone Mtg. Screw, Flat Head #8-32 x 5/16"	14116
38	Flange Mtg. Screw, Flat Head, 5/16-18 x 5/8"	12700
39	Gasket	N/A
40	Mtg. Flange	20640
41	Air Cone	14159
42	Air Tube	20989
43	Gun Assy.	30504-167



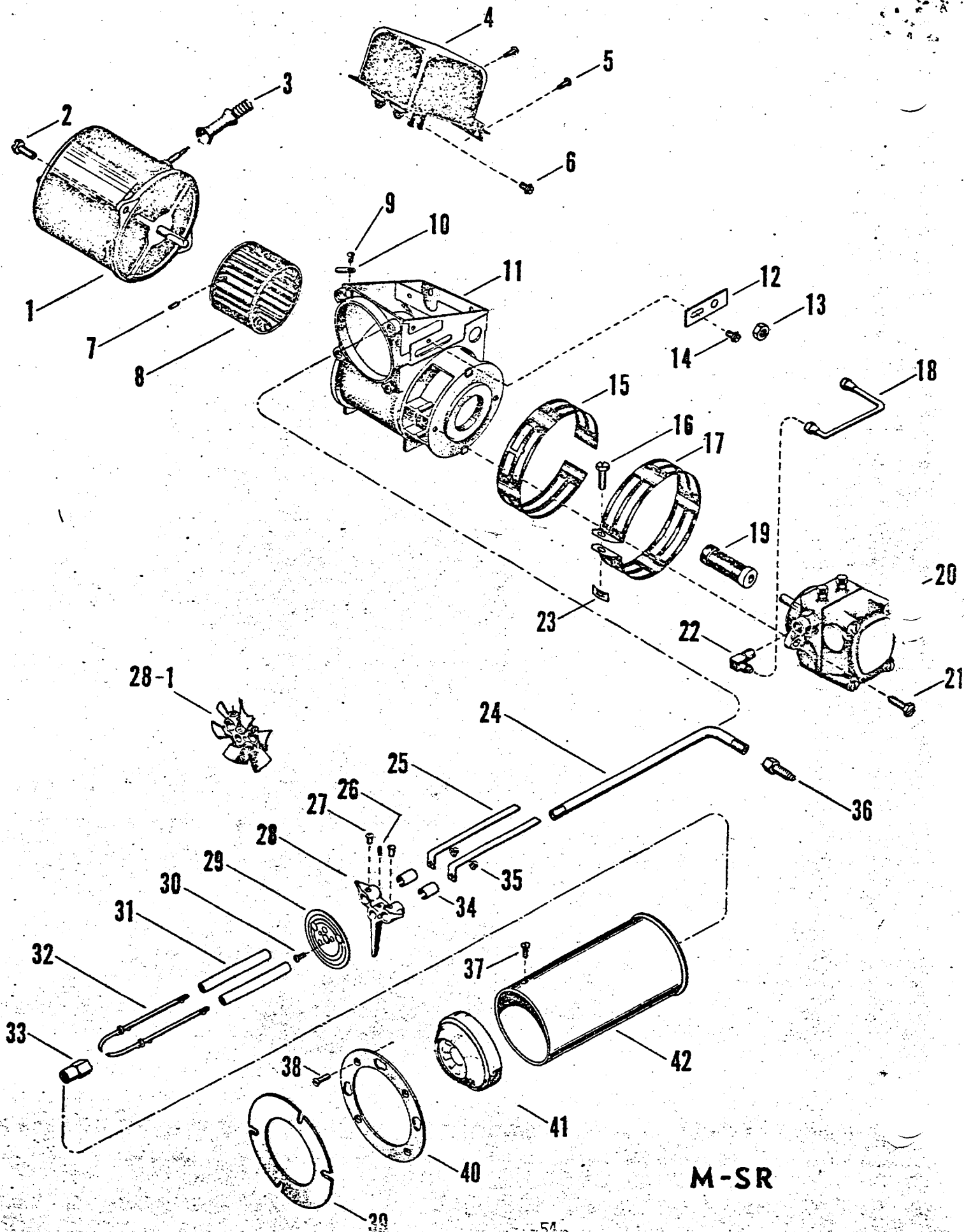

M-SR

PARTS LIST - MODEL OEA 6"  
SPEC. #129-1

<u>ITEM NO.</u>	<u>DESCRIPTION</u>	<u>PART NO.</u>
1	Motor, 1/8 HP - 1725 RPM	20382
2	Motor Mounting Screw	12701
3	Motor Cord Cover	13121
4	Hold Down Clip Screw	13360
5	Transformer Hold Down Clip	13038
6	Fan Set Screw (Included w/Fan)	-
7	Fan, 6-1/4" Dia.	20289
8	Fan Housing Assembly	4725
9	Air Adjusting Band - Inner	2669
10	Oil Line Slot Cover Screw	12697
11	Oil Line Adj. Slot Cover	12338
12	Oil Line Locknut	12342
13	Oil Line Assembly	13368
14	Air Band Screw	12701
15	Air Adjusting Band - Outer	2668
16	Tinnerman Speed Nut	12343
17	Pump Coupling	13279
18	Oil Line Elbow	13270
19	Fuel Unit - Sundstrand ALVA-7012	13512
20	Fuel Unit Mounting Screw	12701
21	Oil Line Fitting	12335
22	Oil Pipe for 6" Tube	12334
23	Buss Bar for 6" Tube	12331
24	Set Screw (Included w/Electrode Support)	-
25	Electrode Support Screw	12694
26	Electrode Support	13418
27	Baffle Plate - 3-1/2"	12567
28	Baffle Plate Screw	12695
29	Insulator	12354
30	Electrode Stem & Washer	12550
31	Nozzle Adapter	12362
32	Flange Mounting Screw	12700
33	Air Cone Mounting Screw	12699
34	Insulator Bushing	12408
35	Palnut	13110
36	Air Tube - 6"	2718
37	Air Cone - 2-1/4"	12337
38	Flange	2685
39	Gasket	12484
41	J-Box	20369
42	Locknut, 1/2"	12910
43	Washer Spacer, 3/4" x 1/2"	13167
44	Chase Nipple, 1/2"	12909
45	Transformer, 115-60	20358
46	Transformer Hinge Screw	13045
47	Cad Cell Mounting Bracket	12951
48	Cad Cell - As Specified	None
49	J-Box Mounting Screw	13036
	Transformer Pkg. (Items 4, 5, 45 & 46)	3349
	Gun Assy (Items 21 thru 31 + 34 & 35) (600H)	2752
	Electrode Assy (Items 29, 30 & 35)	12575

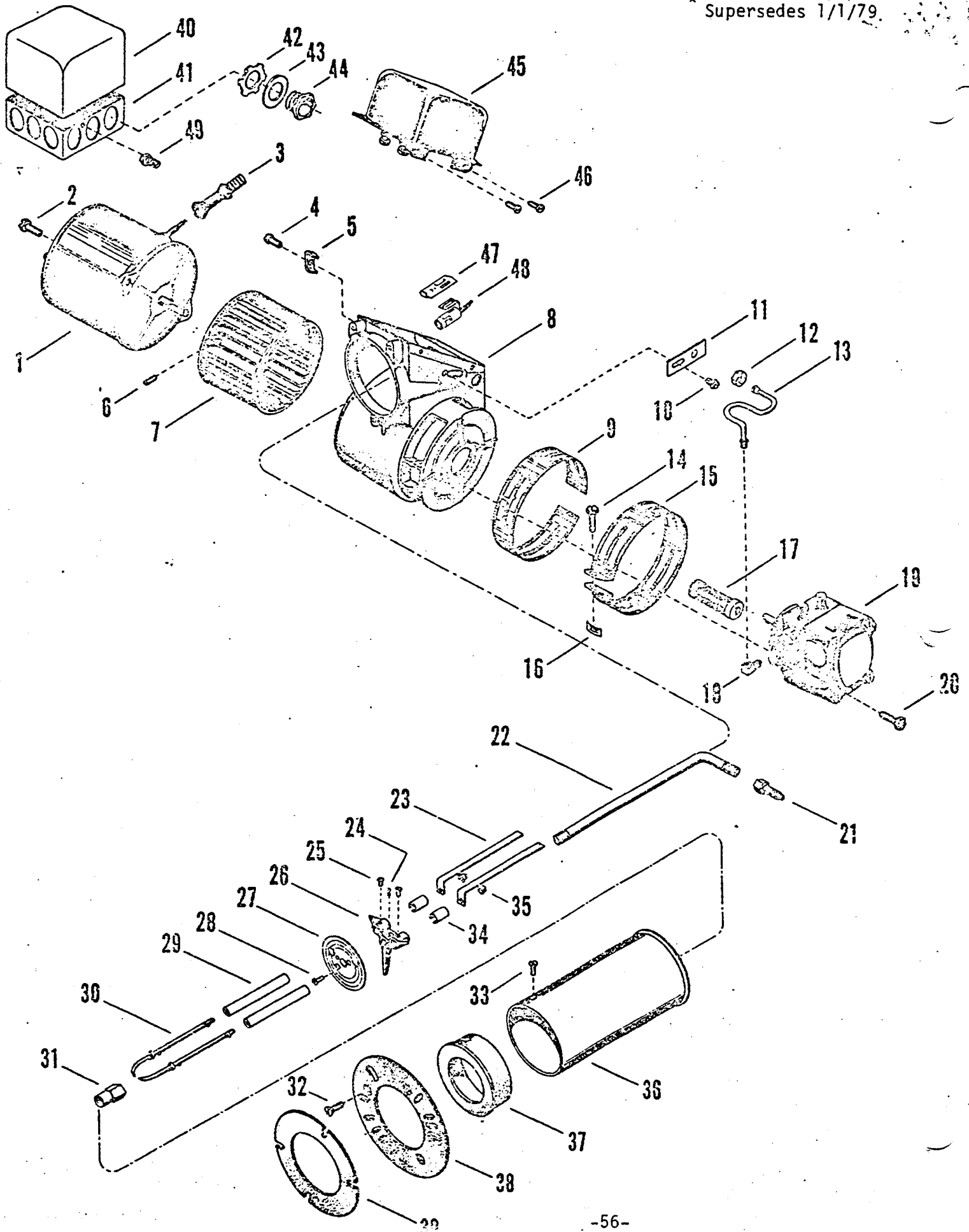

PARTS LIST - MODEL OEA 8"  
SPEC. #129-3

<u>ITEM NO.</u>	<u>DESCRIPTION</u>	<u>PART NO.</u>
1	Motor, 1/8 HP - 1725 RPM	20382
2	Motor Mounting Screw	12701
3	Motor Cord Cover	13121
4	Hold Down Clip Screw	13360
5	Transformer Hold Down Clip	13038
6	Fan Set Screw (Included w/Fan)	-
7	Fan, 6-1/4" Dia.	20289
8	Fan Housing Assembly	4725
9	Air Adjusting Band - Inner	2669
10	Oil Line Slot Cover Screw	12697
11	Oil Line Adj. Slot Cover	12338
12	Oil Line Locknut	12342
13	Oil Line Assembly	13368
14	Air Band Screw	12701
15	Air Adjusting Band - Outer	2668
16	Tinnerman Speed Nut	12343
17	Pump Coupling	13279
18	Oil Line Elbow	13270
19	Fuel Unit - Sundstrand ALVA-7012	13512
20	Fuel Unit Mounting Screw	12701
21	Oil Line Fitting	12335
22	Oil Pipe for 8" Tube	12346
23	Buss Bar For 8" Tube	12344
24	Set Screw (Incl. w/Electrode Support)	-
25	Electrode Support Screw	12694
26	Electrode Support	13418
27	Baffle Plate	12567
28	Baffle Plate Screw	12695
29	Insulator	12354
30	Electrode Stem & Washer	12550
31	Nozzle Adapter	12362
32	Flange Mounting Screw	12700
33	Air Cone Mounting Screw	12699
34	Insulator Bushing	12408
35	Palnut	13110
36	Air Tube - 8"	2721
37	Air Cone - 2-1/4"	12337
38	Flange	2685
39	Gasket	12484
41	J-Box, 4 x 4 x 1-1/2"	20369
42	Locknut, 1/2"	12910
43	Washer Spacer, 3/4" x 1/2"	13167
44	Chase Nipple, 1/2"	12909
45	Transformer, 115-60	20358
46	Transformer Hinge Screw	13045
47	Cad Cell Mounting Bracket	12951
48	Cad Cell	None
49	J-Box Mounting Screw	13036
	Transformer Pkg. (Items 4, 5, 45 & 46)	3349
	Gun Assy. (Items 21 thru 31+ 34 & 35) (800H)	2756
	Electrode Assy. (Items 29, 30 & 35)	12575

Effective 1/1/80  
Supersedes 1/1/79

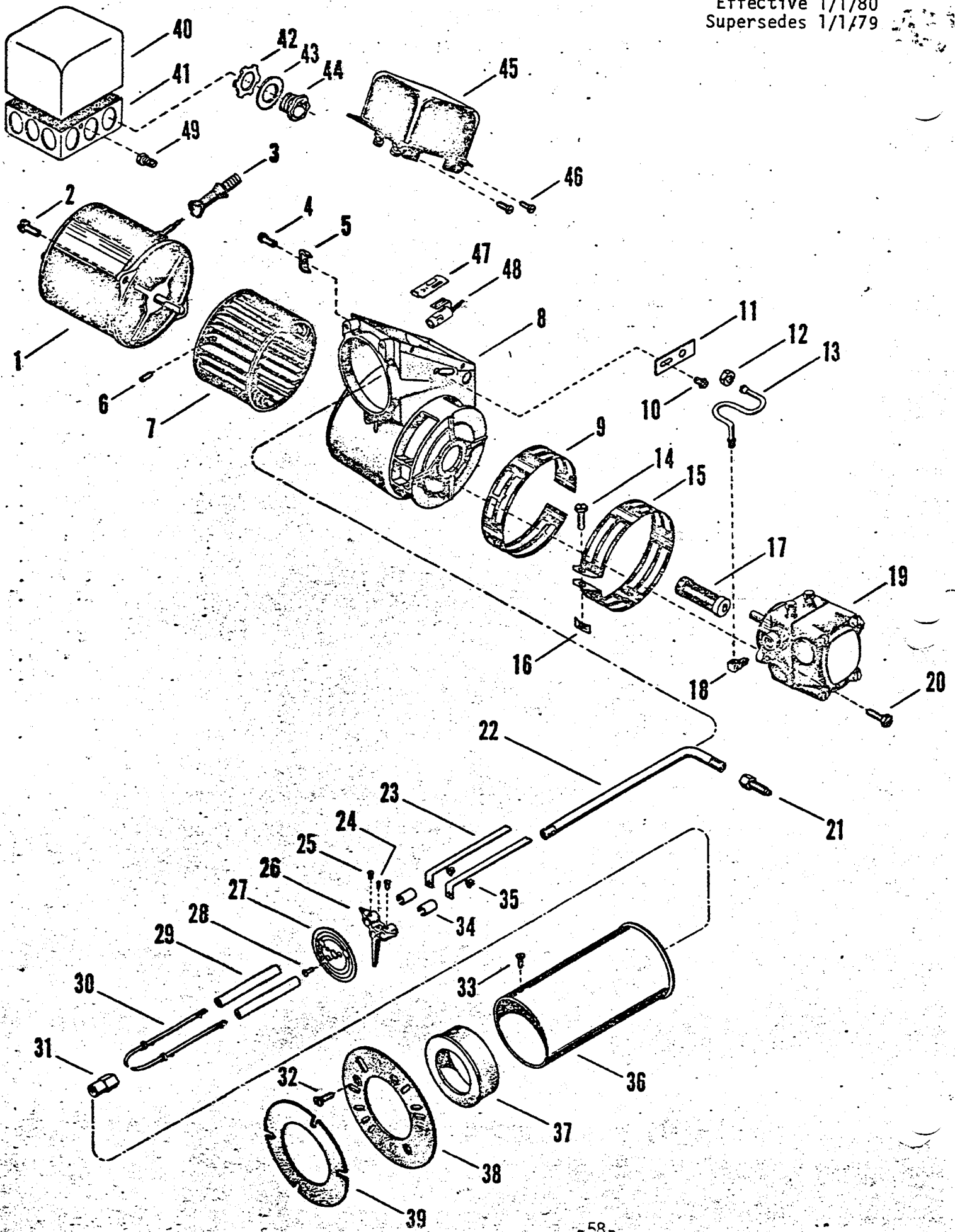

## PARTS LIST

## POWER GAS BURNER

Effective 1/1/80

PART NO.	DESCRIPTION	WP20	WP40
60745	Air Tube and Housing Assembly 8-1/2" Burner	x	x
60814	Air Tube and Housing Assembly 12" Burner	x	x
60815	Air Tube and Housing Assembly 15" Burner	x	x
61460	Cover Plate	x	x
60363	Blower Wheel	x	x
60362	Blower Motor	x	x
60365	Air Shutter	x	x
60650	Housing Wiring Cover	x	x
60211	Mounting Flange	x	x
	Pedestal Mounting Assembly	x	x
60381	Venturi	x	x
60390	Orifice Holder Assembly 8-1/2" Burner	x	x
60391	Orifice Holder Assembly 12" Burner	x	x
60392	Orifice Holder Assembly 15" Burner	x	x
61455	Bulkhead Union	x	x
60364	Motor Bracket	x	x
61055	Main Burner Orifice - Natural Gas	x	x
61056	Main Burner Orifice - L.P. Gas	x	x
60534	Orifice Holder	x	x
60375	Pilot Shield	x	x
60659	Pilot	x	x
60186	Transformer	x	x
60227	Motor Relay	x	x
60228	Terminal Block	x	x
60243	Runner Lighter Tube 8-1/2" Burner	x	x
60244	Runner Lighter Tube 12" Burner	x	x
60245	Runner Lighter Tube 15" Burner	x	x
61430	Runner Lighter Valve 8-1/2" Burner	x	x
61510	Runner Lighter Valve 12-24" Burner	x	x
60374	Pilot Tubing 8-1/2" Burner	x	x
60776	Pilot Tubing 12" Burner	x	x
60777	Pilot Tubing 15" Burner	x	x
60280	Thermocouple 8-1/2" Burner	x	x
60281	Thermocouple 12" & 15" Burner	x	x
60270	Combination Gas Valve - Robertshaw (Natural Gas)	x	
61190	Combination Gas Valve - Robertshaw (L.P. Gas)	x	
60255	Combination Gas Valve - Robertshaw (Natural Gas)		x
60272	Combination Gas Valve - Honeywell (Natural Gas)	x	
61666	Combination Gas Valve - Honeywell (L.P. Gas)	x	
61667	Combination Gas Valve - Honeywell (Natural Gas)		x
60182	Gas Valve Cord Assembly	x	x
60615	Runner Lighter Door	x	x
60748	Flame Retention Ring	x	x
60680	Pilot Orifice - Natural Gas	x	x
60740	Pilot Orifice - L.P. Gas	x	x

Minimum Net Billing \$15.00. Supersedes all previous lists.  
Subject to change without notice. F.O.B. Bryan, Ohio.

*Over for Elec. Section*

PARTS LIST  
ELECTRONIC AIR CLEANER

Effective 1/1/80  
Supersedes 10/78

PART NO.	DESCRIPTION	EC14	EC20
8610-015	Electronic Cell FC37A1130	(2)	
8610-016	Electronic Cell FC37A1064		(2)
8610-017	Cell Handle 137266	(2)	(2)
8610-018	Protective Screen 136388	(2)	
8610-019	Protective Screen 136389		(2)
8610-020	Cell Key 136518	x	x
8610-021	Contact Board 136383A	(2)	(2)
8610-022	Shorting Arm 136387A	x	x
8610-023	Shorting Arm Bracket 136382A	x	x
8610-024	Shorting Arm Spring 136517	x	x
8610-025	Switch/Indicator Light 139034	x	x
8610-026	Power Supply W919A1275	x	
8610-027	Power Supply W919A1267		x
8610-028	High Voltage Transformer 135672AH	x	
8610-029	High Voltage Transformer 136572AF		x
8610-030	Resonating Capacitor 136749	x	x
8610-031	Diode 137073A	(2)	(2)
8610-032	Capacitor 136912	(2)	(2)
8610-033	Resistor 118965A	x	x
	Power Box Assembly 139963C	x	
	Power Box Assembly 139963A		x

Minimum Net Billing \$15.00. Supersedes all previous lists.  
Subject to change without notice. F.O.B. Bryan, Ohio